

*konusulan
the spoken kalite...
quality...*



www.akkо.com.tr

*Kesici Uç Bağlama Sistemleri
Connection Systems For Cutting Inserts*



2014-2015



konusulan
the spoken kalite...
quality...

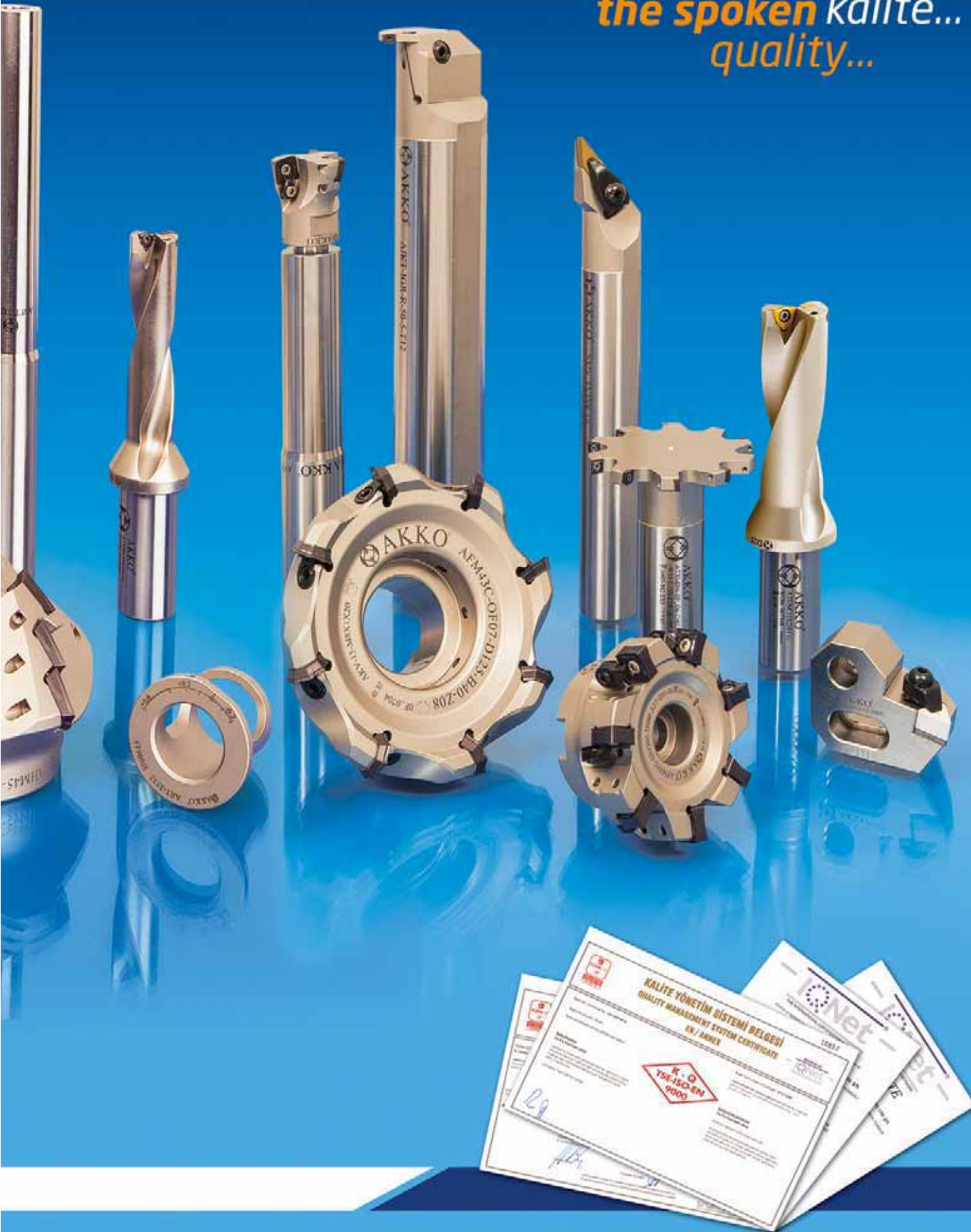



1986 yılında Abdullah KARAKUŞ tarafından kurulan AKKO Oto. Mak. Hırd. San. Tic. Ltd. Şti. Tornalama Takımlarını, Diş ve Kanal Açma Takımlarını, Delik Delme Takımlarını, Frezeleme Takımlarını ve Özel Takımları üretmektedir. Şu an 8000 m²' ye yakın bir alanda Türkiye, Japonya, Almanya, İsveç gibi ülkelerin ürettikleri son teknoloji tezgah ve ekipmanlarıyla yıllık 200.000 adet üretim kapasitesiyle, standart 4000 çeşit takım üretimi yapmaktadır. Avrupa, Asya, Afrika, Güney Amerika ve Orta Doğu Ülkeleri olmak üzere şimdilik 57 ülkeye mal sevkiyatına devam etmekte olup 150.000 adet civarında üretilmiş ürün stoklarında mevcuttur. Firmaya, özel üretilen çelik hammadde işleme girer ve bütün üretim süreci bünyesinde gerçekleşir. Çeliğin işlenmesine, ısıl işlemine, üzerindeki kaplama ve her türlü işlem bir entegre tesis olan AKKO'da gerçekleşir.



We as AKKO Oto. Mak. Hird. San. Tic. Ltd. Şti, which has been founded by Abdullah KARAKUŞ in 1986, produce Turning Tool Holders, Threading and Grooving Tool Holders, U-Drills, Milling Tool Holders and Precision Tool Holders (OEM Tool Holders). We produce standard 4000 kinds of tool holders with production capacity of 200.000 pieces per annum in an area about 8000 square meter. We are going on exporting 57 countries including European, Asian, African, South American Countries and Middle East Countries. We keep ready about 150.000 pieces produced products in our stock. Steel Raw materials that we make produced especially for us are delivered our factory and all production process are made in our factory. All kind of process from machining of steel to heat treatment and coating on our tools are made in our integrated factory AKKO.

| | |
|---------|---|
| | DIŞ TORNA TAKIMLARI |
| S9 | DIŞ TORNA KATERLERİ KODLAMA SİSTEMİ |
| S10-S19 | T-SİSTEM DIŞ TORNA KATERLERİ |
| S20-S22 | M-SİSTEM DIŞ TORNA KATERLERİ |
| S23-S31 | P-SİSTEM DIŞ TORNA KATERLERİ |
| S32-S36 | C-SİSTEM DIŞ TORNA KATERLERİ |
| S37-S49 | S-SİSTEM DIŞ TORNA KATERLERİ |
| S49-S52 | S-SİSTEM İSVEÇ TİPİ KAYAR OTOMAT MAKİNA TAKIMLARI |

| | |
|---------|---------------------------------------|
| | DELİK TORNA TAKIMLARI |
| S54 | DELİK TORNA KATERLERİ KODLAMA SİSTEMİ |
| S55-S60 | T&C SİSTEM DELİK TORNA KATERLERİ |
| S61-S65 | M-SİSTEM DELİK TORNA KATERLERİ |
| S66-S71 | P-SİSTEM DELİK TORNA KATERLERİ |
| S72-S83 | S-SİSTEM DELİK TORNA KATERLERİ |

| | |
|---------|-----------------------------|
| | KARTUŞLAR |
| S85 | KARTUŞLARIN KODLAMA SİSTEMİ |
| S86-S87 | S-TİP HONLAMA KARTUŞLARI |
| S88-S91 | S-SİSTEM KARTUŞLAR |

| | |
|---------|------------------------------------|
| | DIŞ AÇMA TAKIMLARI |
| S93 | DIŞ AÇMA KATERLERİ KODLAMA SİSTEMİ |
| S94-S97 | DIŞ AÇMA KATERLERİ ve TEKNİK BİLGİ |

| | |
|-----------|---|
| | KANAL AÇMA TAKIMLARI |
| S101 | KANAL KATERLERİ KODLAMA SİSTEMİ |
| S102-S112 | DIŞ ÇAP KANAL AÇMA TAKIMLARI |
| S113 | DIŞ ÇAP KANAL AÇMA İSVEÇ TİPİ KAYAR OTOMAT MAKİNA TAKIMLARI |
| S114-S116 | DIŞ ÇAP ALIN KANAL AÇMA TAKIMLARI |
| S117 | L TİP ALIN KANAL AÇMA TAKIMLARI |
| S118 | KESME VE DERİN KANAL AÇMA LAMALARI |
| S118 | KESME VE DERİN KANAL AÇMA LAMA BLOĞU |
| S119-S124 | DELİK İÇİ KANAL KATERLERİ |

| | |
|-----------|---|
| | DELİK DELME ve İŞLEME TAKIMLARI |
| S126-S140 | TAKMA UÇLU MATKAPLAR ve KODLAMA SİSTEMİ |
| S141 | EKSANTRİK U-DRILL ADAPTÖRÜ |
| S142-S144 | EKONOMİK KESİCİLER ve KODLAMA SİSTEMİ |
| S145-S148 | AYARLI DELİK İŞLEME BARALARI ve KODLAMA SİSTEMİ |

| | |
|-----------|--|
| | FREZELEME TAKIMLARI |
| S150 | FREZELEME TAKIMLARI KODLAMA SİSTEMİ |
| S151-S152 | S-SİSTEM PAH FREZELER |
| S152 | SİLİNDİRİK ALYAN BAŞLI VİDA (DIN 974-1) HAVŞALARINI AÇMA FREZELERİ |
| S153-S164 | S-SİSTEM YÜZEY PARMAK FREZELER |
| S164-S165 | S-SİSTEM YÜZEY ve KOPYA PARMAK FREZELER |
| S166-S168 | S-SİSTEM HIZLI İLERLEMELİ PARMAK FREZELER |
| S169-S173 | S-SİSTEM MODÜLER PARMAK FREZELER |
| S174-S176 | S-SİSTEM HIZLI İLERLEMELİ MODÜLER PARMAK FREZELER |
| S177 | KÜRE UÇLU PARMAK FREZELER |
| S178-S179 | VİDALI KÜRE UÇLU PARMAK FREZELER |
| S179 | VİDALI TAKIM TUTUCULARI |
| S180 | DIŞ AÇMA FREZELEME TAKIMLARI |
| S180 | S-SİSTEM HELİS FREZELER |
| S181-S197 | YÜZEY FREZELER |
| S198-S200 | YÜZEY ve KOPYA FREZELER |
| S201-S202 | C-SİSTEM YÜZEY FREZELER |
| S203-S205 | HIZLI İLERLEMELİ FREZELER |
| S206-S207 | T KANAL FREZELER |
| S208 | DİSK FREZELER |
| S209-S211 | FREZELEME TAKIMLARI MONTAJ ÖLÇÜLERİ ve TEKNİK BİLGİLER |

| | |
|-----------|-----------------------|
| | YEDEK PARÇALAR |
| S212-S224 | YEDEK PARÇALAR |

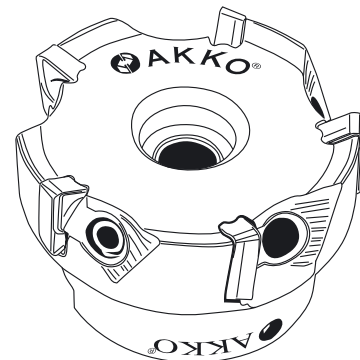
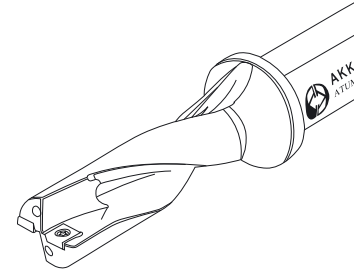
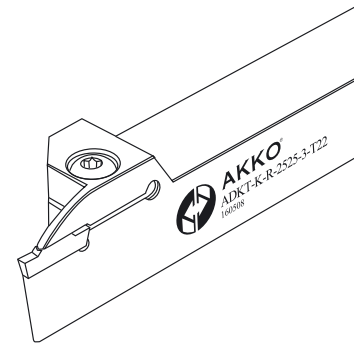
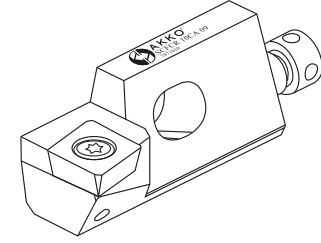
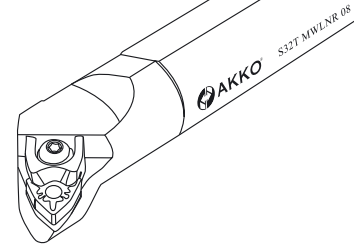
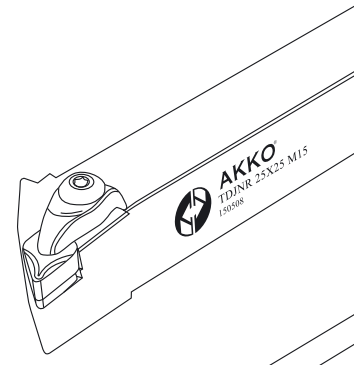

İÇİNDEKİLER

CONTENTS

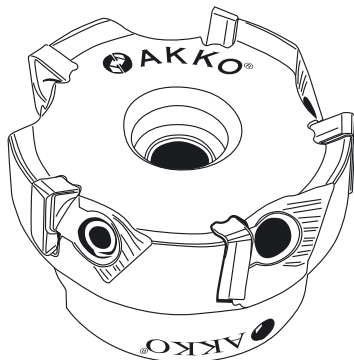
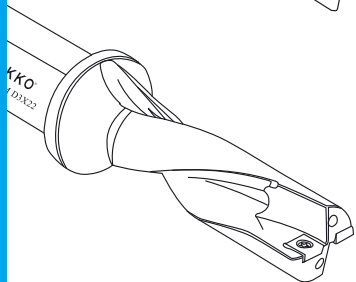
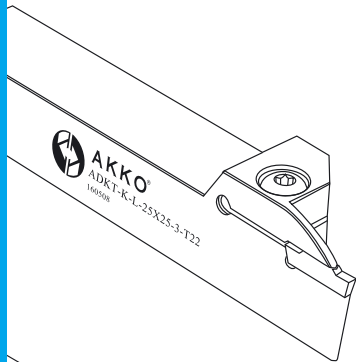
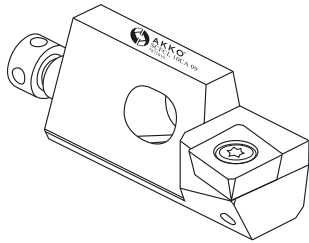
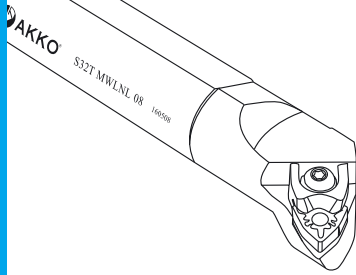
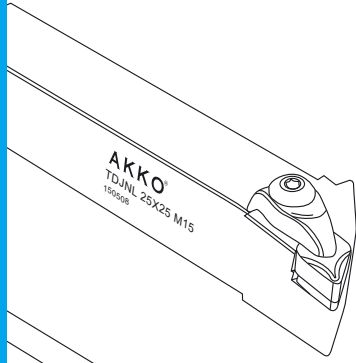

| | |
|-----------|--|
| S9 | EXTERNAL TURNING TOOLHOLDERS |
| S10-S19 | EXTERNAL TURNING TOOLHOLDERS DESIGNATION SYSTEM |
| S20-S22 | T-SYSTEM EXTERNAL TURNING TOOLHOLDERS |
| S23-S31 | M-SYSTEM EXTERNAL TURNING TOOLHOLDERS |
| S32-S36 | P-SYSTEM EXTERNAL TURNING TOOLHOLDERS |
| S37-S49 | C-SYSTEM EXTERNAL TURNING TOOLHOLDERS |
| S49-S52 | S-SYSTEM EXTERNAL TURNING TOOLHOLDERS |
| | S-SYSTEM TOOLS FOR SWISS TYPE SLIDING AUTOMATIC LATHES |
| S54 | INTERNAL TURNING TOOLHOLDERS |
| S55-S60 | BORING BARS DESIGNATION SYSTEM |
| S61-S65 | T&C SYSTEM BORING BARS |
| S66-S71 | M-SYSTEM BORING BARS |
| S72-S83 | P-SYSTEM BORING BARS |
| | S-SYSTEM BORING BARS |
| S85 | CARTRIDGE |
| S86-S87 | CARTRIDGE DESIGNATION SYSTEM |
| S88-S91 | S-TYPE HONING CARTRIDGE |
| | S-SYSTEM CARTRIDGE |
| S93 | THREADING TOOLHOLDERS |
| S94-S97 | THREADING TOOLHOLDERS DESIGNATION SYSTEM |
| | THREADING TOOLHOLDERS and TECHNICAL INFORMATION |
| S101 | GROOVING TOOLHOLDERS |
| S102-S112 | GROOVING TOOLHOLDERS DESIGNATION SYSTEM |
| S113 | EXTERNAL GROOVING TOOLHOLDERS |
| S114-S116 | EXTERNAL GROOVING TOOLHOLDERS FOR SWISS TYPE SLIDING AUTOMATIC LATHES |
| S117 | FACE EXTERNAL GROOVING TOOLHOLDERS |
| S117 | L TYPE FACE EXTERNAL GROOVING TOOLHOLDERS |
| S118 | BLADES FOR PARTING AND DEEP GROOVING |
| S118 | BLOCKS FOR PARTING AND DEEP GROOVING BLADES |
| S119-S124 | INTERNAL GROOVING TOOLHOLDERS |
| S126-S140 | DRILLING and HOLEMAKING TOOLS |
| S141 | U-DRILL SYSTEM and DESIGNATION SYSTEM |
| S142-S144 | EXCENTRIC ADAPTOR FOR U-DRILLS |
| S145-S148 | ECONOMIC CUTTING TOOLS and DESIGNATION SYSTEM |
| | ADJUSTABLE BORING HEADS and DESIGNATION SYSTEM |
| S150 | MILLING TOOLS |
| S151-S152 | MILLING TOOLS DESIGNATION SYSTEM |
| S152 | S-SYSTEM CHAMFERING END MILLS |
| S153-S164 | COUNTERSINK MILLING TOOL FOR CYLINDRICAL ALLEN HEAD SCREWS (DIN 974-1) |
| S164-S165 | S-SYSTEM END MILLS |
| S166-S168 | S-SYSTEM FACE and COPY END MILLS |
| S169-S173 | S-SYSTEM HIGHFEED END MILLS |
| S174-S176 | S-SYSTEM MODULAR END MILLS (SCREW TYPE TOOLS) |
| S177 | S-SYSTEM MODULAR (SCREW TYPE) HIGHFEED END MILLS |
| S178-S179 | BALL NOSE MILLS |
| S179 | BALL NOSE MODULAR (SCREW TYPE) END MILLS |
| S180 | SCREWED TOOL HOLDERS |
| S180 | THREAD MILLING TOOLS |
| S181-S197 | S-SYSTEM HELIX END MILL |
| S198-S200 | FACE MILLING |
| S201-S202 | FACE and COPY MILLING TOOLS |
| S203-S205 | C-SYSTEM FACE MILLING |
| S206-S207 | HIGH FEED MILLING TOOLS |
| S208 | T SLOT MILLING |
| S209-S211 | DISC MILLING |
| | MOUNTING REFERENCE FOR MILLING CUTTERS and TECHNICAL INFORMATION |
| S212-S224 | SPARE PARTS |
| | SPARE PARTS |



DIŞ TORNA TAKIMLARI
EXTERNAL TURNING TOOLHOLDERS





P **S** **K** **N** **R**

1 2 3 4 5

1 Sıkma Tipi / Method of Mounting of Insert

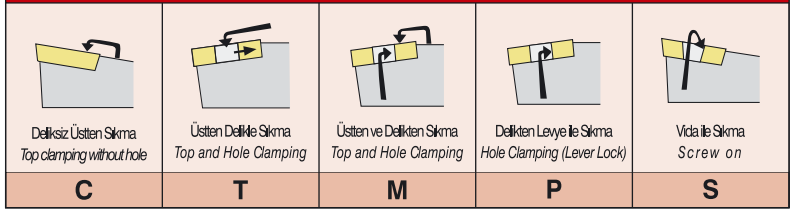

2 Uç Tipi / Insert Shape

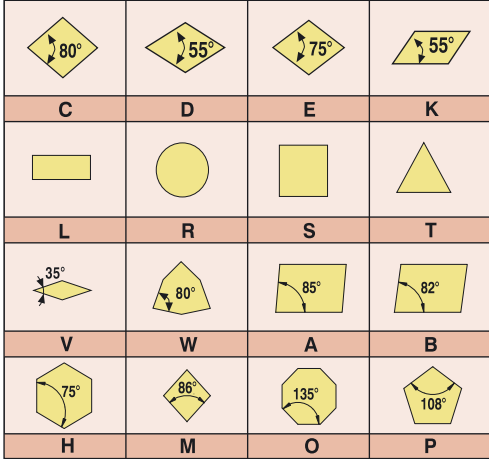

3 Yanaşma Açısı / ToolHolder Shape

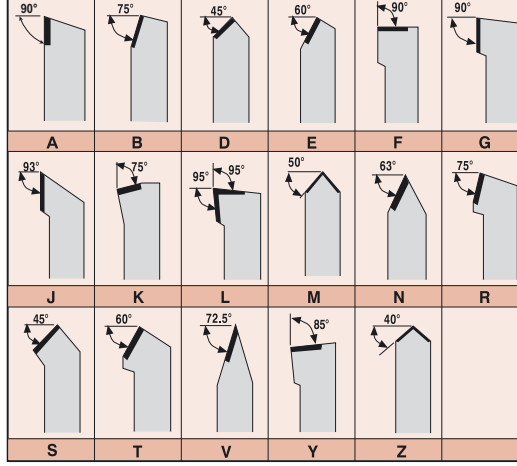

4 Serbest Uç Açısı / Clearance angle of Insert

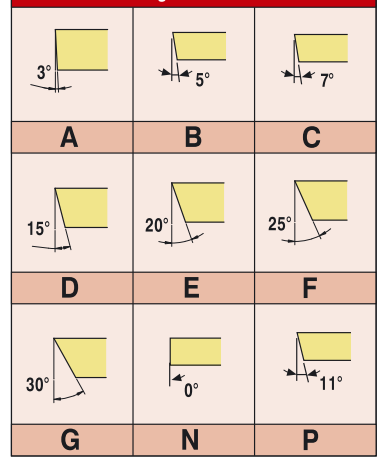

25 **25** - **M** **12** **C**

6 7 8 9 10

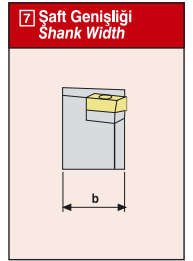
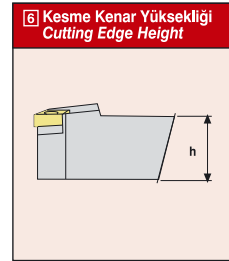
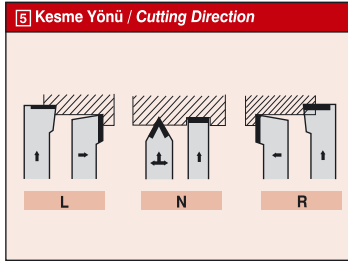

8 Şaft Boyu / Shank Length

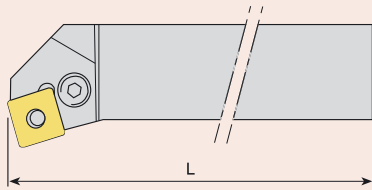

| | | | |
|--------|---------|---------|-----------|
| A - 32 | H - 100 | Q - 180 | x-special |
| B - 40 | J - 110 | R - 200 | |
| C - 50 | K - 125 | S - 250 | |
| D - 60 | L - 140 | T - 300 | |
| E - 70 | M - 150 | U - 350 | |
| F - 80 | N - 160 | V - 400 | |
| G - 90 | P - 170 | W - 450 | |

9 Kesme Kenar Uzunluğu / Cutting Edge Length

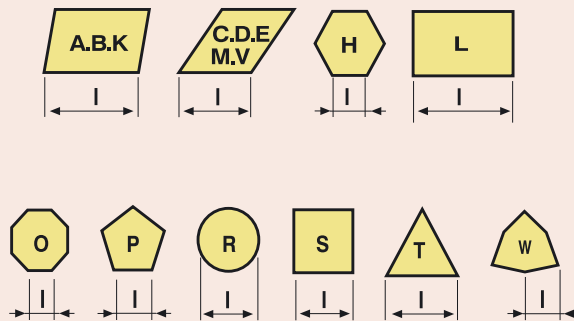

10 Baskı Pabucu / Wedge Clamp

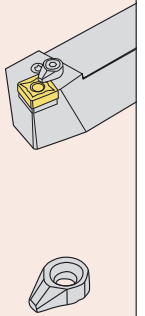



*konusulan
the spoken kalite...
quality...*

T-SİSTEM

T-SİSTEM DIŞ TORNA KATERLERİ

T-SYSTEM EXTERNAL TURNING TOOLHOLDERS



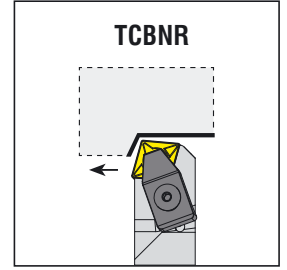
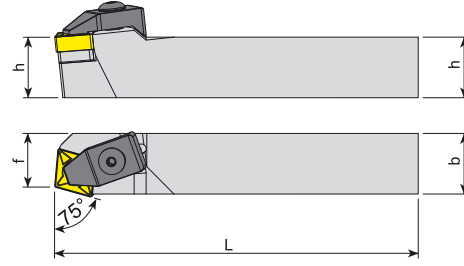

| Takım Kodu Ordering Code | Stok Stock | | Takım Ölçüleri (mm) Dimension (mm) | | | | Kesici Uç Insert | Yedek Parçaları Spare Parts | | | | | | |
|-----------------------------|---------------|---|---------------------------------------|----|-----|----|---------------------|--------------------------------|-----------------------------|---------------|----------------------------|---------------|--------------|----------------------|
| | R | L | h | b | L | f | | Baskı Pabucu Wedge Clamp | Pabuç Vidası Clamp Screw | Altık Shim | Altık Vidası Shim Screw | Yay Spring | Pul Stamp | Anahtar Allen Key |
| | | | | | | | | | | | | | | |
| TCBNR/L 2525 M16 | ● | ● | 25 | 25 | 170 | 22 | CNM. 1606.. | ATK-04 | AKV-19-M7x25 | AACN-3-0002 | AAV-05-M6x15 | - | ABPL-02 | AAL-05-4 |

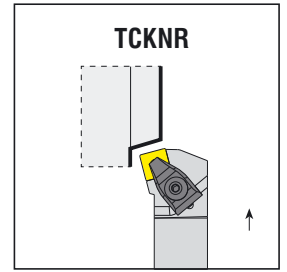
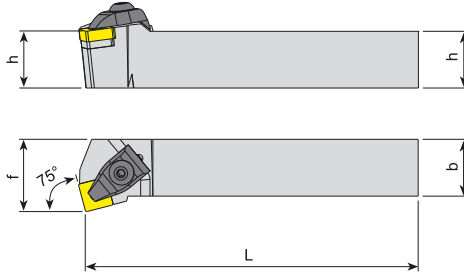

| Takım Kodu Ordering Code | Stok Stock | | Takım Ölçüleri (mm) Dimension (mm) | | | | Kesici Uç Insert | Yedek Parçaları Spare Parts | | | | | | |
|-----------------------------|---------------|---|---------------------------------------|----|-----|----|---------------------|--------------------------------|-----------------------------|---------------|----------------------------|---------------|--------------|----------------------|
| | R | L | h | b | L | f | | Baskı Pabucu Wedge Clamp | Pabuç Vidası Clamp Screw | Altık Shim | Altık Vidası Shim Screw | Yay Spring | Pul Stamp | Anahtar Allen Key |
| | | | | | | | | | | | | | | |
| TCKNR/L 2020 K12 | ○ | ○ | 20 | 20 | 125 | 25 | CNM. 1204.. | ATK-02 | AKV-02-M6x22 | AACN-3-0001 | AAV-02-M5x12 | AKY-01 | ABPL-01 | AAL-03-3 |
| 2525 M12 | ● | ● | 25 | 25 | 150 | 32 | | | | | | | | |
| 3232 P12 | ● | ● | 32 | 32 | 170 | 40 | | | | | | | | |
| 2525 M16 | ● | ● | 25 | 25 | 150 | 32 | CNM. 1606.. | ATK-04 | AKV-19-M7x25 | AACN-3-0002 | AAV-05-M6x15 | - | ABPL-02 | AAL-05-4 |
| 3232 P16 | ● | ● | 32 | 32 | 170 | 40 | | | | | | | | |

R: Sağ/Right L: Sol/Left ● Stokta/In Stock ○ Stokta Yok/Non Stock Item

Sipariş Örneği/Ordering Example : 1 ad./pcs. TCBNR 2525 M16

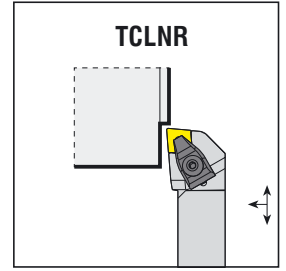
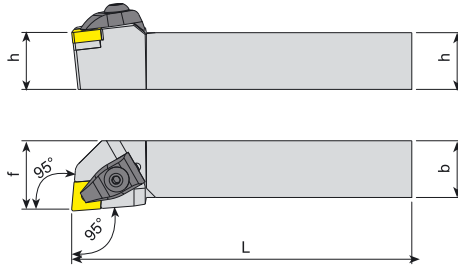

| Takım Kodu Ordering Code | Stok Stock | | Takım Ölçüleri (mm) Dimension (mm) | | | | Kesici Uç Insert | Yedek Parçaları Spare Parts | | | | | | |
|-----------------------------|---------------|---|---------------------------------------|----|-----|----|---------------------|--------------------------------|-----------------------------|----------------|-----------------------------|---------------|--------------|----------------------|
| | R | L | h | b | L | f | | Baskı Pabucu Wedge Clamp | Pabuç Vidası Clamp Screw | Altlık Shim | Altlık Vidası Shim Screw | Yay Spring | Pul Stamp | Anahtar Allen Key |
| TCLNR/L 2020 K12 | ● | ● | 20 | 20 | 125 | 25 | CNM. 1204.. | | | | | | | |
| 2525 M12 | ● | ● | 25 | 25 | 150 | 32 | | | | | | | | |
| 3232 P12 | ● | ● | 32 | 32 | 170 | 40 | | | | | | | | |
| 4040 S12 | ● | ● | 40 | 40 | 250 | 50 | | | | | | | | |
| 5050 S12 | ● | ● | 50 | 50 | 250 | 63 | CNM. 1606.. | | | | | | | |
| 2525 M16 | ● | ● | 25 | 25 | 150 | 32 | | | | | | | | |
| 3232 P16 | ● | ● | 32 | 32 | 170 | 40 | | | | | | | | |

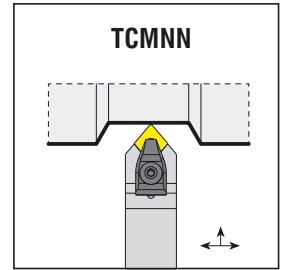
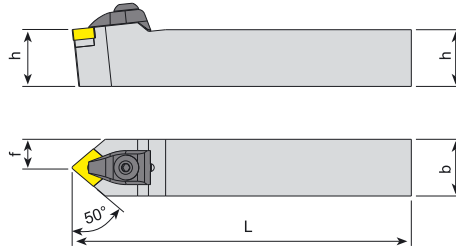

| Takım Kodu Ordering Code | Stok Stock | | Takım Ölçüleri (mm) Dimension (mm) | | | | Kesici Uç Insert | Yedek Parçaları Spare Parts | | | | | | |
|-----------------------------|---------------|---|---------------------------------------|----|-----|------|---------------------|--------------------------------|-----------------------------|----------------|-----------------------------|---------------|--------------|----------------------|
| | R | L | h | b | L | f | | Baskı Pabucu Wedge Clamp | Pabuç Vidası Clamp Screw | Altlık Shim | Altlık Vidası Shim Screw | Yay Spring | Pul Stamp | Anahtar Allen Key |
| TCMNN 1616 H12 | ● | ○ | 16 | 16 | 100 | 8 | CNM. 1204.. | | | | | | | |
| 2020 K12 | ● | ○ | 20 | 20 | 125 | 10 | | | | | | | | |
| 2525 M12 | ● | ○ | 25 | 25 | 150 | 12.5 | | | | | | | | |
| 3232 P12 | ● | ○ | 32 | 32 | 170 | 16 | | | | | | | | |
| 2525 M16 | ● | ○ | 25 | 25 | 150 | 12.5 | CNM. 1606.. | | | | | | | |
| 3232 P16 | ● | ○ | 32 | 32 | 170 | 16 | | | | | | | | |
| 4040 S16 | ○ | ○ | 40 | 40 | 250 | 20 | | | | | | | | |

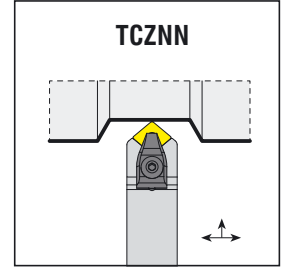
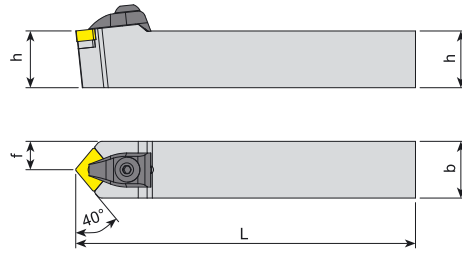

| Takım Kodu Ordering Code | Stok Stock | | Takım Ölçüleri (mm) Dimension (mm) | | | | Kesici Uç Insert | Yedek Parçaları Spare Parts | | | | | | |
|-----------------------------|---------------|---|---------------------------------------|----|-----|------|---------------------|--------------------------------|-----------------------------|----------------|-----------------------------|---------------|--------------|----------------------|
| | R | L | h | b | L | f | | Baskı Pabucu Wedge Clamp | Pabuç Vidası Clamp Screw | Altlık Shim | Altlık Vidası Shim Screw | Yay Spring | Pul Stamp | Anahtar Allen Key |
| TCZNN 2020 K12 | ● | | 20 | 20 | 125 | 10 | | | | | | | | |
| 2525 M12 | ● | | 25 | 25 | 150 | 12.5 | | | | | | | | |
| 3232 P12 | ● | | 32 | 32 | 170 | 16 | | | | | | | | |
| 2525 M16 | ● | | 25 | 25 | 150 | 12.5 | CNM. 1606.. | | | | | - | | |

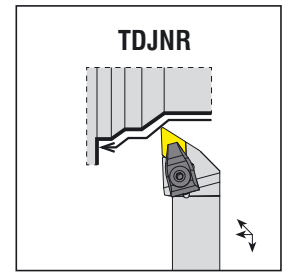
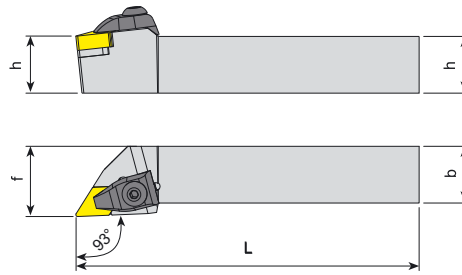

| Takım Kodu Ordering Code | Stok Stock | | Takım Ölçüleri (mm) Dimension (mm) | | | | Kesici Uç Insert | Yedek Parçaları Spare Parts | | | | | | |
|-----------------------------|---------------|---|---------------------------------------|----|-----|----|---------------------|--------------------------------|-----------------------------|----------------|-----------------------------|---------------|--------------|----------------------|
| | R | L | h | b | L | f | | Baskı Pabucu Wedge Clamp | Pabuç Vidası Clamp Screw | Altlık Shim | Altlık Vidası Shim Screw | Yay Spring | Pul Stamp | Anahtar Allen Key |
| TDJNR/L 1616 H11 | ● | ● | 16 | 16 | 100 | 20 | | | | | | | | |
| 2020 K11 | ● | ● | 20 | 20 | 125 | 25 | | | | | | | | |
| 2525 M11 | ● | ● | 25 | 25 | 150 | 32 | | | | | | | | |
| 2020 K15 | ● | ● | 20 | 20 | 125 | 25 | DNM. 1506.. | | | | | | | |
| 2525 M15 | ● | ● | 25 | 25 | 150 | 32 | | | | | | | | |
| 3232 P15 | ● | ● | 32 | 32 | 170 | 40 | | | | | | | | |
| 4040 S15 | ● | ● | 40 | 40 | 250 | 50 | DNM. 1504.. | | | | | | | |
| 5050 S15 | ○ | ○ | 50 | 50 | 250 | 63 | | | | | | | | |
| 2020 K1504 | ● | ● | 20 | 20 | 125 | 25 | | | | | | | | |
| 2525 M1504 | ● | ● | 25 | 25 | 150 | 32 | | | | | | | | |
| 3232 P1504 | ● | ● | 32 | 32 | 170 | 40 | | | | | | | | |
| 4040 S1504 | ● | ● | 40 | 40 | 250 | 50 | | | | | | | | |

R: Sağ/Right L: Sol/Left ● Stokta/In Stock ○ Stokta Yok/Non Stock Item

Sipariş Örneği/Ordering Example : 1 ad./pcs. TCZNN 2020 K12

➤ T-SİSTEM DIŞ TORNA KATERLERİ
T-SYSTEM EXTERNAL TURNING TOOLHOLDERS

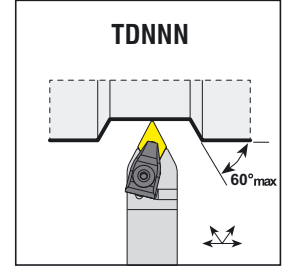
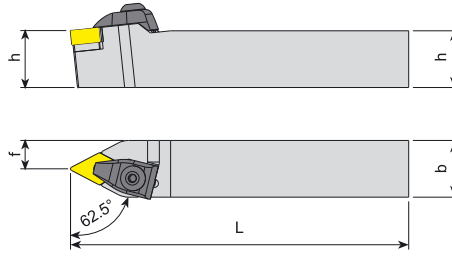

| Takım Kodu Ordering Code | Stok Stock | Takım Ölçüleri (mm) Dimension (mm) | | | | Kesici Uç Insert | Yedek Parçaları Spare Parts | | | | | | |
|-----------------------------|---------------|---------------------------------------|----|-----|------|---------------------|--------------------------------|-----------------------------|----------------|-----------------------------|---------------|--------------|----------------------|
| | | h | b | L | f | | Baskı Pabuçu Wedge Clamp | Pabuç Vidası Clamp Screw | Altlık Shim | Altlık Vidası Shim Screw | Yay Spring | Pul Stamp | Anahtar Allen Key |
| TDNNN 1616 H11 | ● | 16 | 16 | 100 | 8 | DNM. 1104.. | | | | | - | | |
| 2020 K11 | ● | 20 | 20 | 125 | 10 | | | | | | | | |
| 2525 M11 | ● | 25 | 25 | 150 | 12.5 | | | | | | | | |
| 2020 K15 | ● | 20 | 20 | 125 | 10 | DNM. 1506.. | | | | | | | |
| 2525 M15 | ● | 25 | 25 | 150 | 12.5 | | | | | | | | |
| 3232 P15 | ● | 32 | 32 | 170 | 16 | | | | | | | | |
| 4040 S15 | ○ | 40 | 40 | 250 | 20 | | | | | | | | |
| 5050 S15 | ○ | 50 | 50 | 250 | 25 | | | | | | | | |

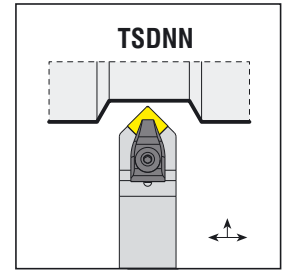
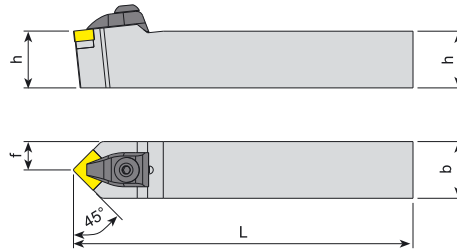

| Takım Kodu Ordering Code | Stok Stock | Takım Ölçüleri (mm) Dimension (mm) | | | | Kesici Uç Insert | Yedek Parçaları Spare Parts | | | | | | |
|-----------------------------|---------------|---------------------------------------|----|-----|------|---------------------|--------------------------------|-----------------------------|----------------|-----------------------------|---------------|--------------|----------------------|
| | | h | b | L | f | | Baskı Pabuçu Wedge Clamp | Pabuç Vidası Clamp Screw | Altlık Shim | Altlık Vidası Shim Screw | Yay Spring | Pul Stamp | Anahtar Allen Key |
| TSDNN 1616 H12 | ● | 16 | 16 | 100 | 8 | SNM. 1204.. | | | | | | | |
| 2020 K12 | ● | 20 | 20 | 125 | 10 | | | | | | | | |
| 2525 M12 | ● | 25 | 25 | 150 | 12.5 | | | | | | | | |
| 3232 P12 | ● | 32 | 32 | 170 | 16 | | | | | | | | |
| 2525 M15 | ○ | 25 | 25 | 150 | 12.5 | SNM. 1506.. | | | | | - | | |
| 3232 P15 | ○ | 32 | 32 | 170 | 16 | | | | | | | | |
| 4040 S15 | ○ | 40 | 40 | 250 | 20 | | | | | | | | |

R: Sağ/Right L: Sol/Left ● Stokta/In Stock ○ Stokta Yok/Non Stock Item

Sipariş Örneği/Ordering Example : 1 ad./pcs. TDNNN 1616 H11



www.akkо.com.tr

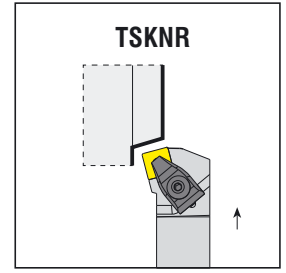
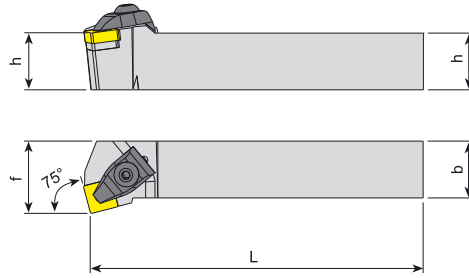

| Takım Kodu Ordering Code | Stok Stock | | Takım Ölçüleri (mm) Dimension (mm) | | | | Kesici Uç Insert | Yedek Parçaları Spare Parts | | | | | | |
|-----------------------------|-------------------------|---|---------------------------------------|----|-----|-----|---------------------|--------------------------------|-----------------------------|-----------------|------------------------------|---------------|--------------|----------------------|
| | R | L | h | b | L | f | | Baskı Pabucu Wedge Clamp | Pabuç Vidası Clamp Screw | Altılık Shim | Altılık Vidası Shim Screw | Yay Spring | Pul Stamp | Anahtar Allen Key |
| | TSKNR/L 2020 K12 | ● | ● | 20 | 20 | 125 | | 25 | | | | | | |
| 2525 M12 | ● | ● | 25 | 25 | 150 | 32 | SNM. 1204.. | ATK-02 | AKV-02-M6x22 | AASN-3-0004 | AAV-02-M5x12 | AKY-01 | ABPL-01 | AAL-03-3 |
| 3232 P12 | ● | ● | 32 | 32 | 170 | 40 | | | | | | | | |
| 3232 P15 | ● | ● | 32 | 32 | 170 | 40 | SNM. 1506.. | ATK-04 | AKV-19-M7x25 | AASN-3-0023 | AAV-05-M6x15 | - | ABPL-02 | AAL-05-4 |

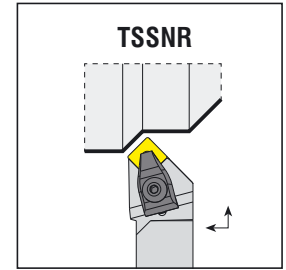
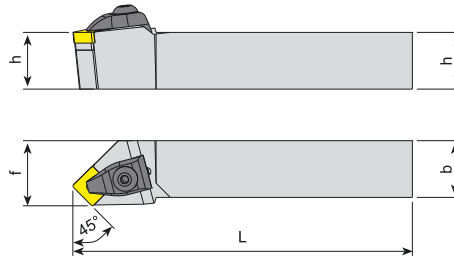

| Takım Kodu Ordering Code | Stok Stock | | Takım Ölçüleri (mm) Dimension (mm) | | | | Kesici Uç Insert | Yedek Parçaları Spare Parts | | | | | | |
|-----------------------------|-------------------------|---|---------------------------------------|----|-----|-----|---------------------|--------------------------------|-----------------------------|-----------------|------------------------------|---------------|--------------|----------------------|
| | R | L | h | b | L | f | | Baskı Pabucu Wedge Clamp | Pabuç Vidası Clamp Screw | Altılık Shim | Altılık Vidası Shim Screw | Yay Spring | Pul Stamp | Anahtar Allen Key |
| | TSSNR/L 2020 K12 | ● | ● | 20 | 20 | 125 | | 25 | | | | | | |
| 2525 M12 | ● | ● | 25 | 25 | 150 | 32 | SNM. 1204.. | ATK-02 | AKV-02-M6x22 | AASN-3-0004 | AAV-02-M5x12 | AKY-01 | ABPL-01 | AAL-03-3 |
| 3232 P12 | ● | ● | 32 | 32 | 170 | 40 | | | | | | | | |
| 2525 M15 | ● | ● | 25 | 25 | 150 | 32 | SNM. 1506.. | ATK-04 | AKV-19-M7x25 | AASN-3-0023 | AAV-05-M6x15 | - | ABPL-02 | AAL-05-4 |
| 3232 P15 | ● | ● | 32 | 32 | 170 | 40 | | | | | | | | |

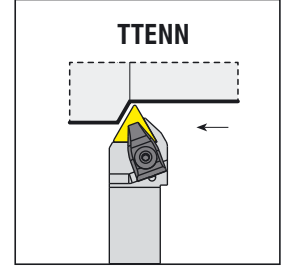
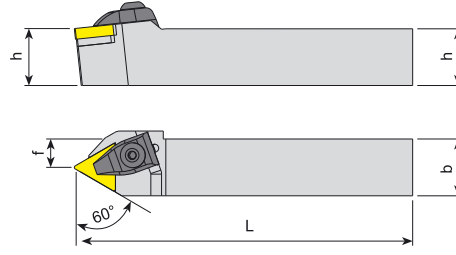

| Takım Kodu Ordering Code | Stok Stock | | Takım Ölçüleri (mm) Dimension (mm) | | | | Kesici Uç Insert | Yedek Parçaları Spare Parts | | | | | | |
|-----------------------------|---------------|---|---------------------------------------|----|-----|------|---------------------|--------------------------------|-----------------------------|-----------------|------------------------------|---------------|--------------|----------------------|
| | R | L | h | b | L | f | | Baskı Pabucu Wedge Clamp | Pabuç Vidası Clamp Screw | Altılık Shim | Altılık Vidası Shim Screw | Yay Spring | Pul Stamp | Anahtar Allen Key |
| TTENN 2020 K16 | ● | | 20 | 20 | 125 | 10 | TNM. 1604.. | | AKV-01-M5x22 | AATN-2-0002 | AAV-03-M5x12 | - | ABPL-01 | AAL-03-3 |
| 2525 M16 | ● | | 25 | 25 | 150 | 12.5 | | | | | | | | |
| 3232 P16 | ● | | 32 | 32 | 170 | 16 | | | | | | | | |
| 2525 M22 | ● | | 25 | 25 | 150 | 12.5 | TNM. 2204.. | | AKV-02-M6x22 | AATN-3-0015 | AAV-02-M5x12 | AKY-01 | ABPL-01 | AAL-03-3 |
| 3232 P22 | ● | | 32 | 32 | 170 | 16 | | | | | | | | |
| 4040 S22 | ○ | | 40 | 40 | 250 | 20 | | | | | | | | |

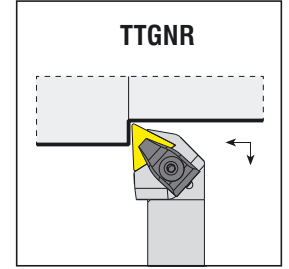
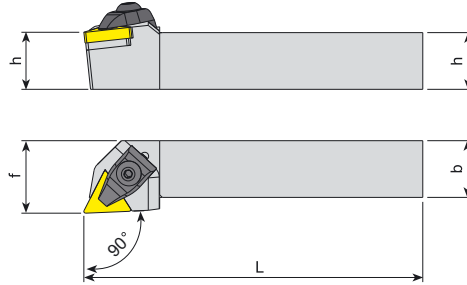

| Takım Kodu Ordering Code | Stok Stock | | Takım Ölçüleri (mm) Dimension (mm) | | | | Kesici Uç Insert | Yedek Parçaları Spare Parts | | | | | | |
|-----------------------------|---------------|---|---------------------------------------|----|-----|----|---------------------|--------------------------------|-----------------------------|-----------------|------------------------------|---------------|--------------|----------------------|
| | R | L | h | b | L | f | | Baskı Pabucu Wedge Clamp | Pabuç Vidası Clamp Screw | Altılık Shim | Altılık Vidası Shim Screw | Yay Spring | Pul Stamp | Anahtar Allen Key |
| TTGNR/L 2020 K16 | ● | ● | 20 | 20 | 125 | 25 | TNM. 1604.. | | AKV-01-M5x22 | AATN-2-0002 | AAV-03-M5x12 | - | ABPL-01 | AAL-03-3 |
| 2525 M16 | ● | ● | 25 | 25 | 150 | 32 | | | | | | | | |
| 3232 P16 | ○ | ○ | 32 | 32 | 170 | 40 | | | | | | | | |
| 2525 M22 | ● | ● | 25 | 25 | 150 | 32 | TNM. 2204.. | | AKV-02-M6x22 | AATN-3-0015 | AAV-02-M5x12 | AKY-01 | ABPL-01 | AAL-03-3 |
| 3232 P22 | ● | ● | 32 | 32 | 170 | 40 | | | | | | | | |
| 4040 S22 | ○ | ○ | 40 | 40 | 250 | 50 | | | | | | | | |

R: Sağ/Right L: Sol/Left ● Stokta/In Stock ○ Stokta Yok/Non Stock Item

Sipariş Örneği/Ordering Example : 1 ad./pcs. TTENN 2020 K16

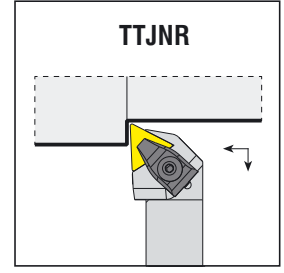
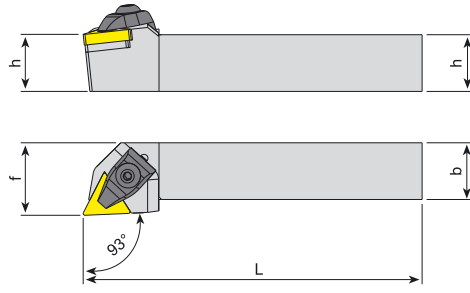

| Takım Kodu Ordering Code | Stok Stock | | Takım Ölçüleri (mm) Dimension (mm) | | | | Kesici Uç Insert | Yedek Parçaları Spare Parts | | | | | | |
|-----------------------------|------------------|---|---------------------------------------|----|-----|-----|---------------------|--------------------------------|-----------------------------|---------------|----------------------------|---------------|--------------|----------------------|
| | R | L | h | b | L | f | | Baskı Pabucu Wedge Clamp | Pabuç Vidası Clamp Screw | Altık Shim | Altık Vidası Shim Screw | Yay Spring | Pul Stamp | Anahtar Allen Key |
| | TTJNR/L 2020 K16 | ● | ● | 20 | 20 | 125 | | 25 | TNM. 1604.. | ATK-01 | AKV-01-M5x22 | AATN-2-0002 | AAV-03-M5x12 | - |
| 2525 M16 | ● | ● | 25 | 25 | 150 | 32 | | | | | | | | |
| 3232 P16 | ● | ● | 32 | 32 | 170 | 40 | | | | | | | | |
| 2525 M22 | ● | ● | 25 | 25 | 150 | 32 | TNM. 2204.. | ATK-02 | AKV-02-M6x22 | AATN-3-0015 | AAV-02-M5x12 | AKY-01 | ABPL-01 | AAL-03-3 |
| 3232 P22 | ● | ● | 32 | 32 | 170 | 40 | | | | | | | | |
| 4040 S22 | ○ | ○ | 40 | 40 | 250 | 50 | | | | | | | | |

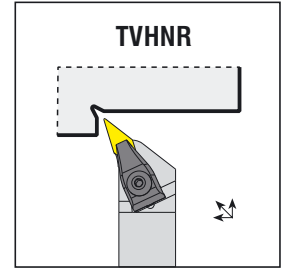
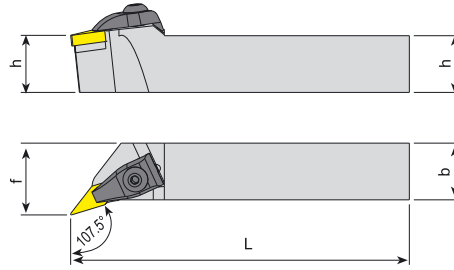

| Takım Kodu Ordering Code | Stok Stock | | Takım Ölçüleri (mm) Dimension (mm) | | | | Kesici Uç Insert | Yedek Parçaları Spare Parts | | | | | | |
|-----------------------------|------------------|---|---------------------------------------|----|-----|-----|---------------------|--------------------------------|-----------------------------|---------------|----------------------------|---------------|--------------|----------------------|
| | R | L | h | b | L | f | | Baskı Pabucu Wedge Clamp | Pabuç Vidası Clamp Screw | Altık Shim | Altık Vidası Shim Screw | Yay Spring | Pul Stamp | Anahtar Allen Key |
| | TVHNR/L 2020 K16 | ● | ● | 20 | 20 | 125 | | 25 | VNM. 1604.. | ATK-03 | AKV-02-M6x22 | AAVN-2-0002 | AAV-04-M5x12 | AKY-01 |
| 2525 M16 | ● | ● | 25 | 25 | 150 | 32 | | | | | | | | |
| 3232 P16 | ○ | ○ | 32 | 32 | 170 | 40 | | | | | | | | |

R: Sağ/Right L: Sol/Left ● Stokta/In Stock ○ Stokta Yok/Non Stock Item

Sipariş Örneği/Ordering Example : 1 ad./pcs. TTJNR 2020 K16

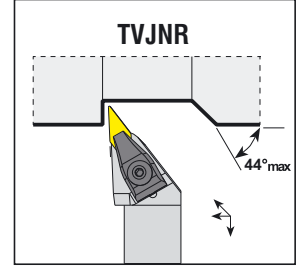
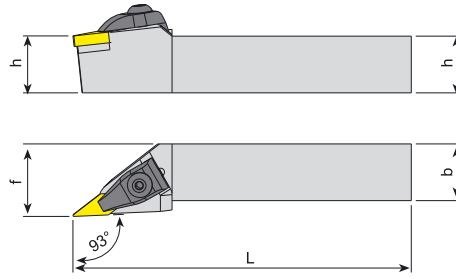

| Takım Kodu Ordering Code | Stok Stock | | Takım Ölçüleri (mm) Dimension (mm) | | | | Kesici Uç Insert | Yedek Parçaları Spare Parts | | | | | | |
|-----------------------------|---------------|---|---------------------------------------|----|-----|----|---------------------|--------------------------------|-----------------------------|---------------|----------------------------|---------------|--------------|----------------------|
| | R | L | h | b | L | f | | Baskı Pabucu Wedge Clamp | Pabuç Vidası Clamp Screw | Altık Shim | Altık Vidası Shim Screw | Yay Spring | Pul Stamp | Anahtar Allen Key |
| TVJNR/L 2020 K16 | ● | ● | 20 | 20 | 125 | 25 | VNM. 1604.. | ATK-03 | AKV-02-M6x22 | AAVN-2-0002 | AAV-04-M5x12 | AKY-01 | ABPL-01 | AAL-03-3 |
| 2525 M16 | ● | ● | 25 | 25 | 150 | 32 | | | | | | | | |
| 3232 P16 | ● | ● | 32 | 32 | 170 | 40 | | | | | | | | |

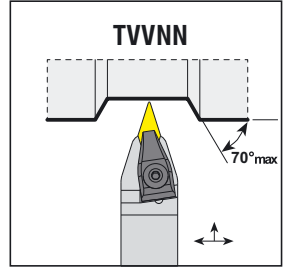
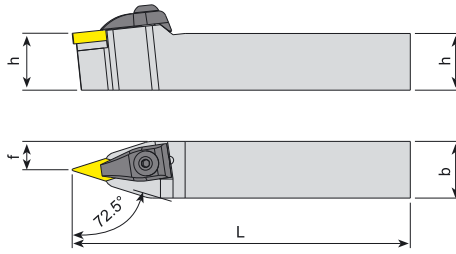

| Takım Kodu Ordering Code | Stok Stock | | Takım Ölçüleri (mm) Dimension (mm) | | | | Kesici Uç Insert | Yedek Parçaları Spare Parts | | | | | | |
|-----------------------------|---------------|---|---------------------------------------|----|-----|------|---------------------|--------------------------------|-----------------------------|---------------|----------------------------|---------------|--------------|----------------------|
| | R | L | h | b | L | f | | Baskı Pabucu Wedge Clamp | Pabuç Vidası Clamp Screw | Altık Shim | Altık Vidası Shim Screw | Yay Spring | Pul Stamp | Anahtar Allen Key |
| TVVNN 2020 K16 | ● | ● | 20 | 20 | 125 | 10 | VNM. 1604.. | ATK-03 | AKV-02-M6x22 | AAVN-2-0002 | AAV-04-M5x12 | AKY-01 | ABPL-01 | AAL-03-3 |
| 2525 M16 | ● | ● | 25 | 25 | 150 | 12.5 | | | | | | | | |
| 3232 P16 | ● | ● | 32 | 32 | 170 | 16 | | | | | | | | |

R: Sağ/Right L: Sol/Left ● Stokta/In Stock ○ Stokta Yok/Non Stock Item

Sipariş Örneği/Ordering Example : 1 ad./pcs. TVJNR 2020 K16

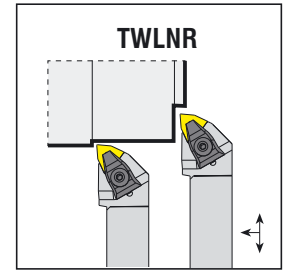
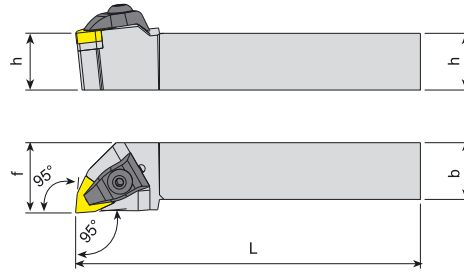

| Takım Kodu Ordering Code | Stok Stock | | Takım Ölçüleri (mm) Dimension (mm) | | | | Kesici Uç Insert | Yedek Parçaları Spare Parts | | | | | | |
|-----------------------------|---------------|---|---------------------------------------|----|-----|----|---------------------|--------------------------------|-----------------------------|-----------------|------------------------------|---------------|--------------|----------------------|
| | R | L | h | b | L | f | | Baskı Pabucu Wedge Clamp | Pabuç Vidası Clamp Screw | Altılık Shim | Altılık Vidası Shim Screw | Yay Spring | Pul Stamp | Anahtar Allen Key |
| TWLNR/L 1616 H06 | ● | ● | 16 | 16 | 100 | 20 | WNM. 0604.. | | AKV-01-M5x22 | AAWN-SW317 | AAV-01-M3x10 | - | ABPL-01 | AAL-03-3 |
| 2020 K06 | ● | ● | 20 | 20 | 125 | 25 | | | | | | | | |
| 2525 M06 | ● | ● | 25 | 25 | 150 | 32 | | | | | | | | |
| 2020 K08 | ● | ● | 20 | 20 | 125 | 25 | | | | | | | | |
| 2525 M08 | ● | ● | 25 | 25 | 150 | 32 | WNM. 0804.. | | AKV-02-M6x22 | AAWN-3-0001 | AAV-02-M5x12 | AKY-01 | ABPL-01 | AAL-03-3 |
| 3232 P08 | ● | ● | 32 | 32 | 170 | 40 | | | | | | | | |
| 4040 S08 | ○ | ○ | 40 | 40 | 250 | 50 | | | | | | | | |
| 5050 S08 | ○ | ○ | 50 | 50 | 250 | 63 | | | | | | | | |

R: Sağ/Right L: Sol/Left ● Stokta/In Stock ○ Stokta Yok/Non Stock Item

Sipariş Örneği/Ordering Example : 1 ad./pcs. TWLNR 1616 H06





*konusulan
the spoken kalite...
quality...*

M-SİSTEM

M-SİSTEM DIŞ TORNA KATERLERİ

M-SYSTEM EXTERNAL TURNING TOOLHOLDERS



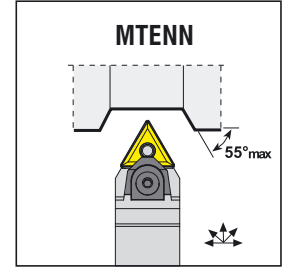
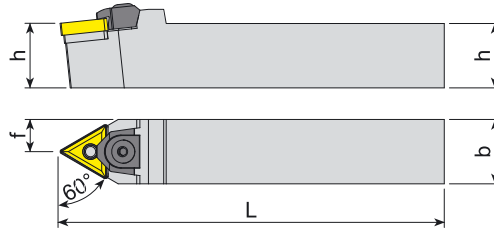

| Takım Kodu Ordering Code | Stok Stock | | Takım Ölçüleri (mm) Dimension (mm) | | | | Kesici Uç Insert | Yedek Parçaları Spare Parts | | | | | | | | | | | | |
|-----------------------------|---------------|---|---------------------------------------|----|-----|------|---------------------|--------------------------------|-----------------------------|---------------|------------|--------------|----------------------|--------------------|--------|--------------|-------------|--------|---------|----------|
| | R | L | h | b | L | f | | Baskı Pabucu Wedge Clamp | Pabuç Vidası Clamp Screw | Altık Shim | Pim Pin | Pul Stamp | Anahtar Allen Key | | | | | | | |
| MTENN 2020 K16 | ● | | 20 | 20 | 125 | 10 | | | | | | | | | | | | | | |
| 2525 M16 | ● | | 25 | 25 | 150 | 12.5 | | | | | | | | TNM. 1604.. | | AATN-2-0002 | APM-01 | | | |
| 3232 P16 | ● | | 32 | 32 | 170 | 16 | | | | | | | | | | | | | | |
| 2525 M22 | ● | | 25 | 25 | 150 | 12.5 | | | | | | | | | AMK-04 | AKV-02-M6x22 | | | ABPL-01 | AAL-03-3 |
| 3232 P22 | ● | | 32 | 32 | 170 | 16 | | | | | | | | TNM. 2204.. | | | AATN-3-0015 | APM-02 | | |
| 4040 S22 | ○ | | 40 | 40 | 250 | 20 | | | | | | | | | | | | | | |

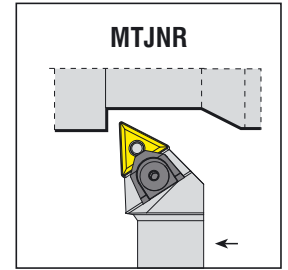
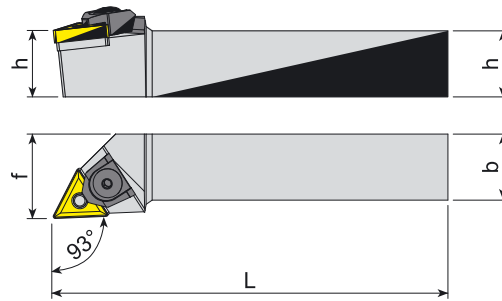

| Takım Kodu Ordering Code | Stok Stock | | Takım Ölçüleri (mm) Dimension (mm) | | | | Kesici Uç Insert | Yedek Parçaları Spare Parts | | | | | | | | | | | | |
|-----------------------------|---------------|---|---------------------------------------|----|-----|----|---------------------|--------------------------------|-----------------------------|---------------|------------|--------------|----------------------|--------------------|--------|--------------|-------------|--------|---------|----------|
| | R | L | h | b | L | f | | Baskı Pabucu Wedge Clamp | Pabuç Vidası Clamp Screw | Altık Shim | Pim Pin | Pul Stamp | Anahtar Allen Key | | | | | | | |
| MTJNR/L 2020 K16 | ● | ● | 20 | 20 | 125 | 25 | | | | | | | | | | | | | | |
| 2525 M16 | ● | ● | 25 | 25 | 150 | 32 | | | | | | | | TNM. 1604.. | | AATN-2-0002 | APM-01 | | | |
| 3232 P16 | ● | ● | 32 | 32 | 170 | 40 | | | | | | | | | | | | | | |
| 2525 M22 | ● | ● | 25 | 25 | 150 | 32 | | | | | | | | | AMK-04 | AKV-02-M6x22 | | | ABPL-01 | AAL-03-3 |
| 3232 P22 | ● | ● | 32 | 32 | 170 | 40 | | | | | | | | TNM. 2204.. | | | AATN-3-0015 | APM-02 | | |
| 4040 S22 | ● | ● | 40 | 40 | 250 | 50 | | | | | | | | | | | | | | |

R: Sağ/Right L: Sol/Left ● Stokta/In Stock ○ Stokta Yok/Non Stock Item

Sipariş Örneği/Ordering Example : 1 ad./pcs. MTENN 2020 K16

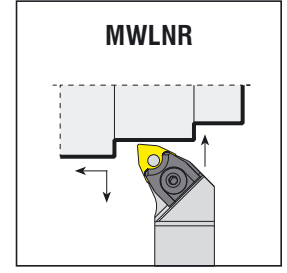
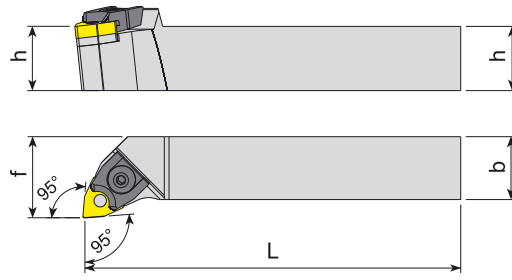

| Takım Kodu Ordering Code | Stok Stock | | Takım Ölçüleri (mm) Dimension (mm) | | | | Kesici Uç Insert | Yedek Parçaları Spare Parts | | | | | |
|-----------------------------|---------------|---|---------------------------------------|----|-----|----|---------------------|--------------------------------|-----------------------------|----------------|------------|--------------|----------------------|
| | R | L | h | b | L | f | | Baskı Pabucu Wedge Clamp | Pabuç Vidası Clamp Screw | Altlık Shim | Pim Pin | Pul Stamp | Anahtar Allen Key |
| MWLNLR/L 1616 H06 | ● | ● | 16 | 16 | 100 | 20 | WNM. 0604.. | AMK-01 | AKV-04-M5x17 | - | APM-08 | - | AAL-03-3 |
| 2020 K06 | ● | ● | 20 | 20 | 125 | 25 | | | | | | | |
| 2525 M06 | ● | ● | 25 | 25 | 150 | 32 | | | | | | | |
| 2020 K08 | ● | ● | 20 | 20 | 125 | 25 | WNM. 0804.. | AMK-05 | AKV-03-M6x22 | AAWN-3-0001 | APM-02 | ABPL-01 | |
| 2525 M08 | ● | ● | 25 | 25 | 150 | 32 | | | | | | | |
| 3232 P08 | ● | ● | 32 | 32 | 170 | 40 | | | | | | | |

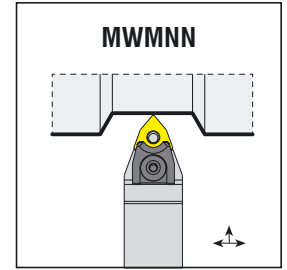
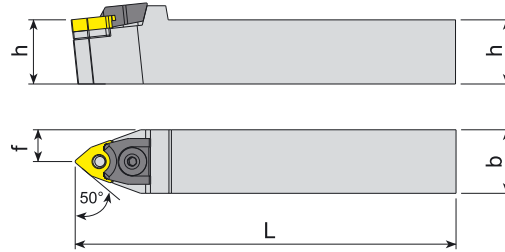

| Takım Kodu Ordering Code | Stok Stock | | Takım Ölçüleri (mm) Dimension (mm) | | | | Kesici Uç Insert | Yedek Parçaları Spare Parts | | | | | |
|-----------------------------|---------------|--|---------------------------------------|----|-----|------|---------------------|--------------------------------|-----------------------------|----------------|------------|--------------|----------------------|
| | | | h | b | L | f | | Baskı Pabucu Wedge Clamp | Pabuç Vidası Clamp Screw | Altlık Shim | Pim Pin | Pul Stamp | Anahtar Allen Key |
| MWMNN 1616 H06 | ○ | | 16 | 16 | 100 | 8 | WNM. 0604.. | AMK-01 | AKV-04-M5x17 | - | APM-08 | - | AAL-03-3 |
| 2020 K06 | ● | | 20 | 20 | 125 | 10 | | | | | | | |
| 2525 M06 | ● | | 25 | 25 | 150 | 12.5 | | | | | | | |
| 2020 K08 | ● | | 20 | 20 | 125 | 10 | WNM. 0804.. | AMK-05 | AKV-03-M6x22 | AAWN-3-0001 | APM-02 | ABPL-01 | |
| 2525 M08 | ● | | 25 | 25 | 150 | 12.5 | | | | | | | |
| 3232 P08 | ● | | 32 | 32 | 170 | 16 | | | | | | | |

R: Sağ/Right L: Sol/Left ● Stokta/In Stock ○ Stokta Yok/Non Stock Item

Sipariş Örneği/Ordering Example : 1 ad./pcs. MWLNLR 1616 H06

P-SİSTEM

P-SİSTEM DIŞ TORNA KATERLERİ

P-SYSTEM EXTERNAL TURNING TOOLHOLDERS

*konusulan
the spoken kalite...
quality...*



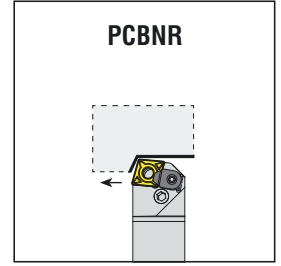
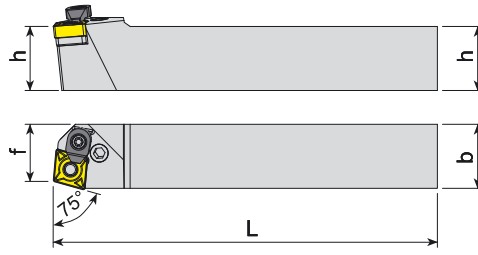

| Takım Kodu Ordering Code | Stok Stock | | Takım Ölçüleri (mm) Dimension (mm) | | | | Kesici Uç Insert | Yedek Parçaları Spare Parts | | | | | | |
|-----------------------------|---------------|---|---------------------------------------|----|-----|------|---------------------|--------------------------------|-----------------------------|----------------|----------------------------|------------------------------|-----------------------------|----------------------|
| | R | L | h | b | L | f | | Levye Lever | Levye Vidası Lever Screw | Altlık Shim | Altlık Yayı Shim Spring | Baskı Parçası Wedge Clamp | Baskı Vidası Clamp Screw | Anahtar Allen Key |
| | ● | ○ | | | | | | | | | | | | |
| PCBNR/L 2020 K12C | ● | ● | 20 | 20 | 125 | 17.5 | | | ALV-03-M8x19 | AACN-3-0001 | AAY-02 | ACK-05 | 1515-M4x11 | AAL-03-3 |
| 2525 M12C | ● | ● | 25 | 25 | 150 | 22.5 | CNM. 1204.. | APL-02 | ALV-03-M8x19 | AACN-3-0001 | AAY-02 | ACK-05 | 1515-M4x11 | AAL-03-3 |
| 3232 P12C | ● | ● | 32 | 32 | 170 | 27.5 | CNM. 1606.. | APL-04 | ALV-04-M8x22 | AACN-3-0002 | AAY-03 | ACK-09 | AAV-05-M6x15 | AAL-05-4 |
| 2525 M16C | ● | ● | 25 | 25 | 150 | 22 | CNM. 1906.. | APL-05 | ALV-05-M10x27 | AACN-3-0003 | AAY-04 | ACK-09 | AAV-05-M6x15 | AAL-05-4 |
| 3232 P16C | ● | ● | 32 | 32 | 170 | 27 | CNM. 2509.. | APL-06 | ALV-06-M12x36 | AACN-3-0008 | AAY-05 | ACK-04 | AKV-16-M6x16 | AAL-07-5 |
| 3232 P19C | ● | ● | 32 | 32 | 170 | 27 | | | | | | | | |
| 4040 S19C | ● | ● | 40 | 40 | 250 | 37 | | | | | | | | |
| 4040 S25C | ● | ● | 40 | 40 | 250 | 37 | | | | | | | | |
| 5050 S25C | ○ | ○ | 50 | 50 | 250 | 47 | | | | | | | | |

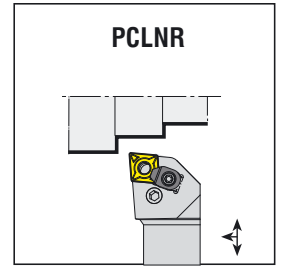
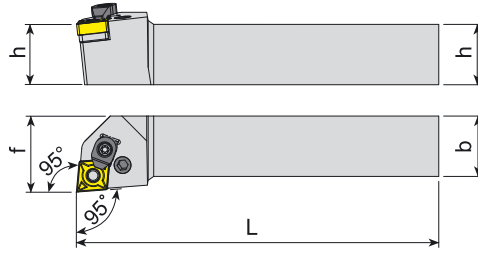

| Takım Kodu Ordering Code | Stok Stock | | Takım Ölçüleri (mm) Dimension (mm) | | | | Kesici Uç Insert | Yedek Parçaları Spare Parts | | | | | | |
|-----------------------------|---------------|---|---------------------------------------|----|-----|----|---------------------|--------------------------------|-----------------------------|----------------|----------------------------|------------------------------|-----------------------------|----------------------|
| | R | L | h | b | L | f | | Levye Lever | Levye Vidası Lever Screw | Altlık Shim | Altlık Yayı Shim Spring | Baskı Parçası Wedge Clamp | Baskı Vidası Clamp Screw | Anahtar Allen Key |
| | ● | ○ | | | | | | | | | | | | |
| PCLNR/L 1616 H09 | ● | ● | 16 | 16 | 100 | 20 | CNM. 0903.. | APL-01 | ALV-02-M6x17 | AACN-2-0002 | AAY-01 | - | - | AAL-02-2.5 |
| 2020 K09 | ● | ● | 20 | 20 | 125 | 25 | CNM. 1204.. | APL-02 | ALV-03-M8x19 | AACN-3-0001 | AAY-02 | ACK-05 | 1515-M4x11 | AAL-03-3 |
| 2525 M09 | ● | ● | 25 | 25 | 150 | 32 | CNM. 1606.. | APL-04 | ALV-04-M8x22 | AACN-3-0002 | AAY-03 | ACK-09 | AAV-05-M6x15 | AAL-05-4 |
| 1616 H12C | ● | ● | 16 | 16 | 100 | 20 | CNM. 1906.. | APL-05 | ALV-05-M10x27 | AACN-3-0003 | AAY-04 | ACK-09 | AAV-05-M6x15 | AAL-05-4 |
| 2020 K12C | ● | ● | 20 | 20 | 125 | 25 | CNM. 2509.. | APL-06 | ALV-06-M12x36 | AACN-3-0008 | AAY-05 | ACK-04 | AKV-16-M6x16 | AAL-07-5 |
| 2525 M12C | ● | ● | 25 | 25 | 150 | 32 | | | | | | | | |
| 3232 P12C | ● | ● | 32 | 32 | 170 | 40 | | | | | | | | |
| 2525 M16C | ● | ● | 25 | 25 | 150 | 32 | | | | | | | | |
| 3232 P16C | ● | ● | 32 | 32 | 170 | 40 | | | | | | | | |
| 2525 M19C | ● | ● | 25 | 25 | 150 | 32 | | | | | | | | |
| 3232 P19C | ● | ● | 32 | 32 | 170 | 40 | | | | | | | | |
| 4040 S19C | ● | ● | 40 | 40 | 250 | 50 | | | | | | | | |
| 4040 S25C | ● | ● | 40 | 40 | 250 | 50 | | | | | | | | |
| 5050 S25C | ● | ● | 50 | 50 | 250 | 60 | | | | | | | | |

R: Sağ/Right L: Sol/Left ● Stokta/In Stock ○ Stokta Yok/Non Stock Item

Sipariş Örneği/Ordering Example : 1 ad./pcs. PCBNR 2020 K12C

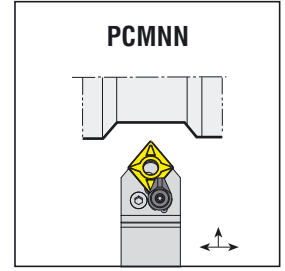
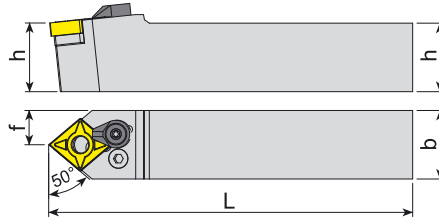

| Takım Kodu Ordering Code | Stok Stock | | Takım Ölçüleri (mm) Dimension (mm) | | | | Kesici Uç Insert | Yedek Parçaları Spare Parts | | | | | | |
|-----------------------------|---------------|---|---------------------------------------|----|-----|------|---------------------|--------------------------------|-----------------------------|----------------|----------------------------|------------------------------|-----------------------------|----------------------|
| | R | L | h | b | L | f | | Levye Lever | Levye Vidası Lever Screw | Aitlik Shim | Aitlik Yayı Shim Spring | Baskı Parçası Wedge Clamp | Baskı Vidası Clamp Screw | Anahtar Allen Key |
| PCMNN 2020 K12C | ● | | 20 | 20 | 125 | 10 | CNM. 1204.. | | | | | | | |
| 2525 M12C | ● | | 25 | 25 | 150 | 12.5 | | | | | | | | |
| 3232 P12C | ○ | | 32 | 32 | 170 | 16 | | | | | | | | |
| 2525 M16C | ○ | | 25 | 25 | 150 | 12.5 | CNM. 1606.. | | | | | | | |
| 3232 P16C | ○ | | 32 | 32 | 170 | 16 | | | | | | | | |
| 3232 P19C | ● | | 32 | 32 | 170 | 16 | | | | | | | | |
| 4040 S19C | ○ | | 40 | 40 | 250 | 20 | CNM. 1906.. | | | | | | | |
| 5050 S19C | ○ | | 50 | 50 | 250 | 25 | | | | | | | | |
| 4040 S25C | ● | | 40 | 40 | 250 | 20 | CNM. 2509.. | | | | | | | |

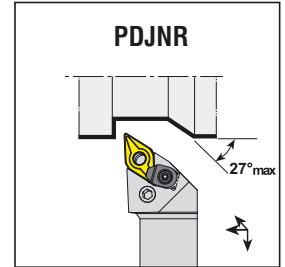
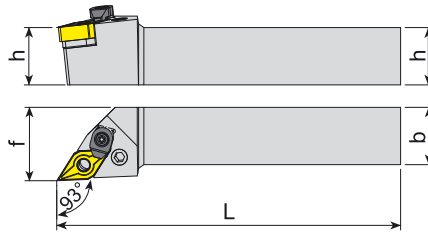

| Takım Kodu Ordering Code | Stok Stock | | Takım Ölçüleri (mm) Dimension (mm) | | | | Kesici Uç Insert | Yedek Parçaları Spare Parts | | | | | | |
|-----------------------------|---------------|---|---------------------------------------|----|-----|----|---------------------|--------------------------------|-----------------------------|----------------|----------------------------|------------------------------|-----------------------------|----------------------|
| | R | L | h | b | L | f | | Levye Lever | Levye Vidası Lever Screw | Aitlik Shim | Aitlik Yayı Shim Spring | Baskı Parçası Wedge Clamp | Baskı Vidası Clamp Screw | Anahtar Allen Key |
| PDJNR/L 1616 H11 | ● | ● | 16 | 16 | 100 | 20 | DNM. 1104.. | | | | | | | |
| 2020 K11 | ● | ● | 20 | 20 | 125 | 25 | | | | | | | | |
| 2525 M11 | ● | ● | 25 | 25 | 150 | 32 | | | | | | | | |
| 2020 K15C | ● | ● | 20 | 20 | 125 | 25 | DNM. 1506.. | | | | | | | |
| 2525 M15C | ● | ● | 25 | 25 | 150 | 32 | | | | | | | | |
| 3232 P15C | ● | ● | 32 | 32 | 170 | 40 | | | | | | | | |
| 4040 S15C | ● | ● | 40 | 40 | 250 | 50 | | | | | | | | |

R: Sağ/Right L: Sol/Left ● Stokta/In Stock ○ Stokta Yok/Non Stock Item

Sipariş Örneği/Ordering Example : 1 ad./pcs. PCMNN 2020 K12C

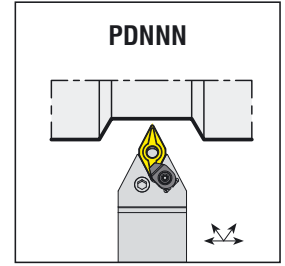
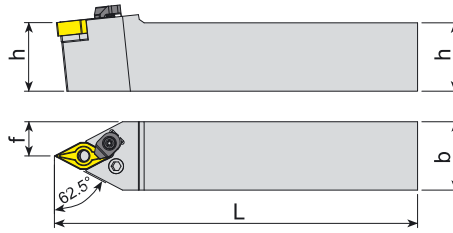

| Takım Kodu Ordering Code | Stok Stock | | Takım Ölçüleri (mm) Dimension (mm) | | | | Kesici Uç Insert | Yedek Parçaları Spare Parts | | | | | | |
|-----------------------------|---------------|---|---------------------------------------|----|-----|------|---------------------|--------------------------------|-----------------------------|----------------|----------------------------|------------------------------|-----------------------------|----------------------|
| | R | L | h | b | L | f | | Levye Lever | Levye Vidası Lever Screw | Altlık Shim | Altlık Yayı Shim Spring | Baskı Parçası Wedge Clamp | Baskı Vidası Clamp Screw | Anahtar Allen Key |
| PDNNN 1616 H11 | ● | | 16 | 16 | 100 | 8 | DNM. 1104.. | APL-01 | ALV-02-M6x17 | AADN-SD317 | AAY-01 | - | - | AAL-02-2.5 |
| 2020 K11 | ● | | 20 | 20 | 125 | 10 | | | | | | | | |
| 2525 M11 | ● | | 25 | 25 | 150 | 12.5 | | | | | | | | |
| 2020 K15 | ● | | 20 | 20 | 125 | 10 | DNM. 1506.. | APL-03 | ALV-03-M8x19 | AADN-3-0001 | AAY-02 | ACK-05 | 1515-M4x11 | AAL-03-3 |
| 2525 M15C | ● | | 25 | 25 | 150 | 12.5 | | | | | | | | |
| 3232 P15C | ● | | 32 | 32 | 170 | 16 | | | | | | | | |

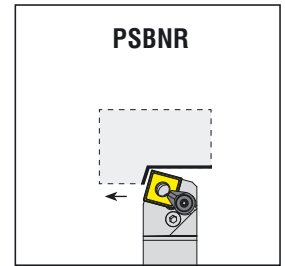
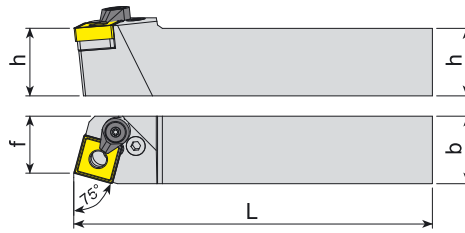

| Takım Kodu Ordering Code | Stok Stock | | Takım Ölçüleri (mm) Dimension (mm) | | | | Kesici Uç Insert | Yedek Parçaları Spare Parts | | | | | | |
|-----------------------------|---------------|---|---------------------------------------|----|-----|----|---------------------|--------------------------------|-----------------------------|----------------|----------------------------|------------------------------|-----------------------------|----------------------|
| | R | L | h | b | L | f | | Levye Lever | Levye Vidası Lever Screw | Altlık Shim | Altlık Yayı Shim Spring | Baskı Parçası Wedge Clamp | Baskı Vidası Clamp Screw | Anahtar Allen Key |
| PSBNR/L 1616 H09 | ○ | ○ | 16 | 16 | 100 | 13 | SNM. 0903.. | APL-01 | ALV-02-M6x17 | AASN-2-0002 | AAY-01 | - | - | AAL-02-2.5 |
| 2020 K09 | ○ | ○ | 20 | 20 | 125 | 17 | | | | | | | | |
| 2020 K12 | ● | ● | 20 | 20 | 125 | 17 | | | | | | | | |
| 2525 M12C | ● | ● | 25 | 25 | 150 | 22 | SNM. 1204.. | APL-02 | ALV-03-M8x19 | AASN-3-0004 | AAY-02 | ACK-05 | 1515-M4x11 | AAL-03-3 |
| 3232 P12C | ○ | ○ | 32 | 32 | 170 | 27 | | | | | | | | |
| 2525 M15C | ○ | ○ | 25 | 25 | 150 | 22 | SNM. 1506.. | APL-04 | ALV-04-M8x22 | AASN-3-0023 | AAY-03 | ACK-09 | AAV-05-M6x15 | AAL-05-4 |
| 3232 P19C | ● | ● | 32 | 32 | 170 | 27 | | | | | | | | |
| 4040 S19C | ● | ● | 40 | 40 | 250 | 35 | SNM. 1906.. | APL-05 | ALV-05-M10x27 | AASN-3-0005 | AAY-04 | ACK-09 | AAV-05-M6x15 | AAL-05-4 |
| 4040 S25C | ○ | ○ | 40 | 40 | 250 | 35 | | | | | | | | |
| 5050 S25C | ○ | ○ | 50 | 50 | 250 | 43 | SNM. 2509.. | APL-06 | ALV-06-M12x36 | AASN-3-0020 | AAY-05 | ACK-04 | AKV-16-M6x16 | AAL-07-5 |

R: Sağ/Right L: Sol/Left ● Stokta/In Stock ○ Stokta Yok/Non Stock Item

Sipariş Örneği/Ordering Example : 1 ad./pcs. PSBNR 1616 H09

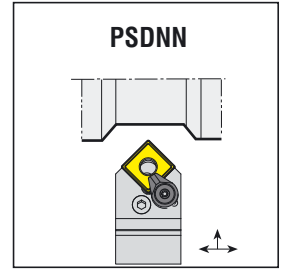
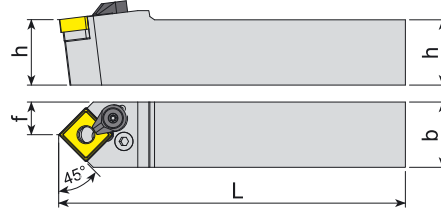

| Takım Kodu Ordering Code | Stok Stock | Takım Ölçüleri (mm) Dimension (mm) | | | | | Kesici Uç Insert | Yedek Parçaları Spare Parts | | | | | |
|-----------------------------|---------------|---------------------------------------|----|-----|------|--------------------|---------------------|--------------------------------|----------------|----------------------------|------------------------------|-----------------------------|----------------------|
| | | h | b | L | f | Levye Lever | | Levye Vidası Lever Screw | Altlık Shim | Altlık Yayı Shim Spring | Baskı Parçası Wedge Clamp | Baskı Vidası Clamp Screw | Anahtar Allen Key |
| | | | | | | | | | | | | | |
| PSDNN 1616 H09 | ○ | 16 | 16 | 100 | 8 | | APL-01 | ALV-02-M6x17 | AASN-2-0002 | AAY-01 | - | - | AAL-02-2.5 |
| 2020 K12C | ● | 20 | 20 | 125 | 10 | | | | | | | | |
| 2525 M12C | ● | 25 | 25 | 150 | 12.5 | SNM. 1204.. | APL-02 | ALV-03-M8x19 | AASN-3-0004 | AAY-02 | ACK-05 | 1515-M4x11 | AAL-03-3 |
| 3232 P12C | ● | 32 | 32 | 170 | 16 | | | | | | | | |
| 2020 K15C | ○ | 20 | 20 | 125 | 10 | | | | | | | | |
| 2525 M15C | ● | 25 | 25 | 150 | 12.5 | SNM. 1506.. | APL-04 | ALV-04-M8x22 | AASN-3-0023 | AAY-03 | | | |
| 3232 P19C | ● | 32 | 32 | 170 | 16 | | | | | | | | |
| 4040 S19C | ○ | 40 | 40 | 250 | 20 | SNM. 1906.. | APL-05 | ALV-05-M10x27 | AASN-3-0005 | AAY-04 | ACK-09 | AAV-05-M6x15 | AAL-05-4 |
| 5050 S19C | ○ | 50 | 50 | 250 | 25 | | | | | | | | |
| 4040 S25C | ○ | 40 | 40 | 250 | 20 | | | | | | | | |
| 5050 S25C | ○ | 50 | 50 | 250 | 25 | SNM. 2509.. | APL-06 | ALV-06-M12x36 | AASN-3-0020 | AAY-05 | ACK-04 | AKV-16-M6x16 | AAL-07-5 |

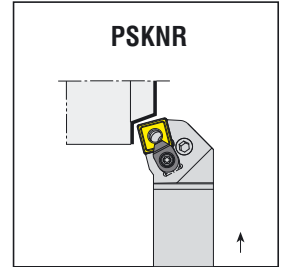
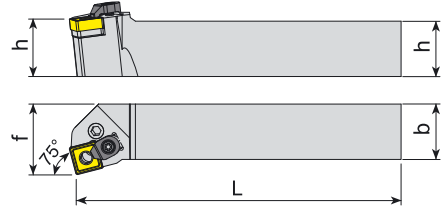

| Takım Kodu Ordering Code | Stok Stock | | Takım Ölçüleri (mm) Dimension (mm) | | | | | Kesici Uç Insert | Yedek Parçaları Spare Parts | | | | | |
|-----------------------------|---------------|---|---------------------------------------|----|-----|----|--------------------|---------------------|--------------------------------|----------------|----------------------------|------------------------------|-----------------------------|----------------------|
| | R | L | h | b | L | f | Levye Lever | | Levye Vidası Lever Screw | Altlık Shim | Altlık Yayı Shim Spring | Baskı Parçası Wedge Clamp | Baskı Vidası Clamp Screw | Anahtar Allen Key |
| | | | | | | | | | | | | | | |
| PSKNR/L 2020 K09 | ○ | ○ | 20 | 20 | 125 | 25 | | APL-01 | ALV-02-M6x17 | AASN-2-0002 | AAY-01 | - | - | AAL-02-2.5 |
| 2020 K12C | ● | ● | 20 | 20 | 125 | 25 | | | | | | | | |
| 2525 M12C | ● | ● | 25 | 25 | 150 | 32 | SNM. 1204.. | APL-02 | ALV-03-M8x19 | AASN-3-0004 | AAY-02 | ACK-05 | 1515-M4x11 | AAL-03-3 |
| 3232 P12C | ● | ● | 32 | 32 | 170 | 40 | | | | | | | | |
| 2525 M15C | ● | ● | 25 | 25 | 150 | 32 | | | | | | | | |
| 3232 P15C | ○ | ○ | 32 | 32 | 170 | 40 | SNM. 1506.. | APL-04 | ALV-04-M8x22 | AASN-3-0023 | AAY-03 | | | |
| 3232 P19C | ○ | ○ | 32 | 32 | 170 | 40 | | | | | | | | |
| 4040 S19C | ○ | ○ | 40 | 40 | 250 | 50 | SNM. 1906.. | APL-05 | ALV-05-M10x27 | AASN-3-0005 | AAY-04 | ACK-09 | AAV-05-M6x15 | AAL-05-4 |
| 4040 S25C | ○ | ○ | 40 | 40 | 250 | 50 | | | | | | | | |
| 5050 S25C | ○ | ○ | 50 | 50 | 250 | 60 | SNM. 2509.. | APL-06 | ALV-06-M12x36 | AASN-3-0020 | AAY-05 | ACK-04 | AKV-16-M6x16 | AAL-07-5 |

R: Sağ/Right L: Sol/Left ● Stokta/In Stock ○ Stokta Yok/Non Stock Item

Sipariş Örneği/Ordering Example : 1 ad./pcs. PSDNN 1616 H09

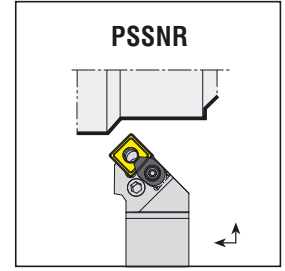
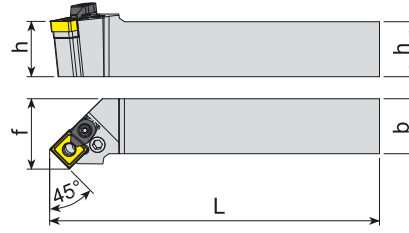

| Takım Kodu Ordering Code | Stok Stock | | Takım Ölçüleri (mm) Dimension (mm) | | | | Kesici Uç Insert | Yedek Parçaları Spare Parts | | | | | | |
|-----------------------------|---------------|---|---------------------------------------|----|-----|----|---------------------|--------------------------------|-----------------------------|----------------|----------------------------|------------------------------|-----------------------------|----------------------|
| | R | L | h | b | L | f | | Levye Lever | Levye Vidası Lever Screw | Altlık Shim | Altlık Yayı Shim Spring | Baskı Parçası Wedge Clamp | Baskı Vidası Clamp Screw | Anahtar Allen Key |
| | ○ | ● | | | | | | | | | | | | |
| PSSNR/L 1616 H09 | ○ | ○ | 16 | 16 | 100 | 20 | SNM. 0903.. | APL-01 | ALV-02-M6x17 | AASN-2-0002 | AAV-01 | - | - | AAL-02-2.5 |
| 2020 K09 | ○ | ○ | 20 | 20 | 125 | 25 | | | | | | | | |
| 2020 K12C | ● | ● | 20 | 20 | 125 | 25 | SNM. 1204.. | APL-02 | ALV-03-M8x19 | AASN-3-0004 | AAV-02 | ACK-05 | 1515-M4x11 | AAL-03-3 |
| 2525 M12C | ● | ● | 25 | 25 | 150 | 32 | | | | | | | | |
| 3232 P12C | ● | ● | 32 | 32 | 170 | 40 | SNM. 1506.. | APL-04 | ALV-04-M8x22 | AASN-3-0023 | AAV-03 | ACK-09 | AAV-05-M6x15 | AAL-05-4 |
| 3232 P15C | ○ | ○ | 32 | 32 | 170 | 40 | | | | | | | | |
| 3232 P19C | ● | ● | 32 | 32 | 170 | 40 | SNM. 1906.. | APL-05 | ALV-05-M10x27 | AASN-3-0005 | AAV-04 | ACK-04 | AKV-16-M6x16 | AAL-07-5 |
| 4040 S19C | ● | ● | 40 | 40 | 250 | 50 | | | | | | | | |
| 4040 S25C | ● | ● | 40 | 40 | 250 | 50 | SNM. 2509.. | APL-06 | ALV-06-M12x36 | AASN-3-0020 | AAV-05 | ACK-04 | AKV-16-M6x16 | AAL-07-5 |

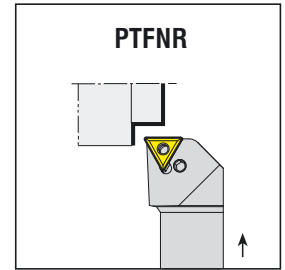
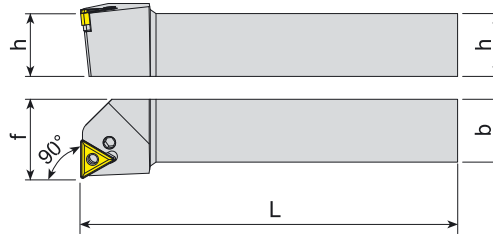

| Takım Kodu Ordering Code | Stok Stock | | Takım Ölçüleri (mm) Dimension (mm) | | | | Kesici Uç Insert | Yedek Parçaları Spare Parts | | | | | | |
|-----------------------------|---------------|---|---------------------------------------|----|-----|----|---------------------|--------------------------------|-----------------------------|----------------|----------------------------|------------------------------|-----------------------------|----------------------|
| | R | L | h | b | L | f | | Levye Lever | Levye Vidası Lever Screw | Altlık Shim | Altlık Yayı Shim Spring | Baskı Parçası Wedge Clamp | Baskı Vidası Clamp Screw | Anahtar Allen Key |
| | ○ | ● | | | | | | | | | | | | |
| PTFNR/L 1616 H16 | ● | ● | 16 | 16 | 100 | 20 | TNM. 1604.. | APL-01 | ALV-02-M6x17 | AATN-3-0025 | AAV-01 | - | - | AAL-02-2.5 |
| 2020 K16 | ● | ● | 20 | 20 | 125 | 25 | | | | | | | | |
| 2525 M16 | ● | ● | 25 | 25 | 150 | 32 | | | | | | | | |
| 3232 P16 | ● | ● | 32 | 32 | 170 | 40 | | | | | | | | |
| 2525 M22C | ● | ● | 25 | 25 | 150 | 32 | TNM. 2204.. | APL-02 | ALV-03-M8x19 | AATN-3-0015 | AAV-02 | ACK-05 | 1515-M4x11 | AAL-03-3 |
| 3232 P22C | ● | ● | 32 | 32 | 170 | 40 | | | | | | | | |
| 4040 S27 | ○ | ○ | 40 | 40 | 250 | 50 | TNM. 2706. | 07042709 | 07042710 | 07042701 | 07042711 | - | - | AAL-05-4 |

R: Sağ/Right L: Sol/Left ● Stokta/In Stock ○ Stokta Yok/Non Stock Item

Sipariş Örneği/Ordering Example : 1 ad./pcs. PSSNR 1616 H09

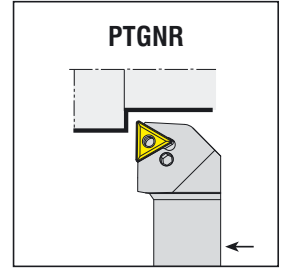
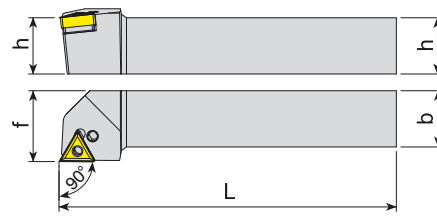

| Takım Kodu Ordering Code | Stok Stock | | Takım Ölçüleri (mm) Dimension (mm) | | | | Kesici Uç Insert | Yedek Parçaları Spare Parts | | | | | | | |
|-----------------------------|---------------|---|---------------------------------------|----|-----|----|---------------------|--------------------------------|-------------------------------|-----------------|-----------------------------|------------------------------|-----------------------------|----------------------|------------|
| | R | L | h | b | L | f | | Levyeye Lever | Levyeye Vidası Lever Screw | Altılık Shim | Altılık Yayı Shim Spring | Baskı Parçası Wedge Clamp | Baskı Vidası Clamp Screw | Anahtar Allen Key | |
| | | | | | | | | | | | | | | | |
| PTG NR/L 1010 E11 | ○ | ○ | 10 | 10 | 70 | 12 | TNM. 1103.. | | 07041109 | 07041110 | - | - | - | - | AAL-02-2.5 |
| 1212 F11 | ○ | ○ | 12 | 12 | 80 | 16 | | | | | | | | | |
| 1616 H11 | ○ | ○ | 16 | 16 | 100 | 20 | | | | | | | | | |
| 1616 H16 | ● | ● | 16 | 16 | 100 | 20 | TNM. 1604.. | APL-01 | ALV-02-M6x17 | AATN-3-0025 | AAY-01 | - | - | - | |
| 2020 K16 | ● | ● | 20 | 20 | 125 | 25 | | | | | | | | | |
| 2525 M16 | ● | ● | 25 | 25 | 150 | 32 | | | | | | | | | |
| 3232 P16 | ○ | ○ | 32 | 32 | 170 | 40 | TNM. 2204.. | APL-02 | ALV-03-M8x19 | AATN-3-0015 | AAY-02 | ACK-05 | 1515-M4x11 | AAL-03-3 | |
| 2525 M22C | ● | ● | 25 | 25 | 150 | 32 | | | | | | | | | |
| 3232 P22C | ○ | ○ | 32 | 32 | 170 | 40 | | | | | | | | | |
| 4040 S27 | ○ | ○ | 40 | 40 | 250 | 50 | TNM. 2706.. | 07042709 | 07042710 | 07042701 | 07042711 | - | - | AAL-05-4 | |

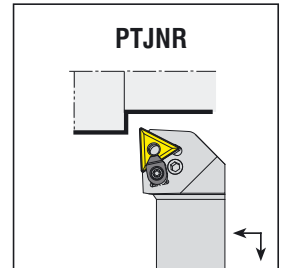
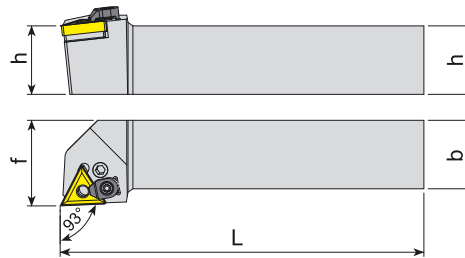

| Takım Kodu Ordering Code | Stok Stock | | Takım Ölçüleri (mm) Dimension (mm) | | | | Kesici Uç Insert | Yedek Parçaları Spare Parts | | | | | | | |
|-----------------------------|---------------|---|---------------------------------------|----|-----|----|---------------------|--------------------------------|-------------------------------|-----------------|-----------------------------|------------------------------|-----------------------------|----------------------|------------|
| | R | L | h | b | L | f | | Levyeye Lever | Levyeye Vidası Lever Screw | Altılık Shim | Altılık Yayı Shim Spring | Baskı Parçası Wedge Clamp | Baskı Vidası Clamp Screw | Anahtar Allen Key | |
| | | | | | | | | | | | | | | | |
| PTJ NR/L 1010 E11 | ○ | ○ | 10 | 10 | 70 | 12 | TNM. 1103.. | | 07041109 | 07041110 | - | - | - | - | AAL-02-2.5 |
| 1212 F11 | ○ | ○ | 12 | 12 | 80 | 16 | | | | | | | | | |
| 1616 H11 | ○ | ○ | 16 | 16 | 100 | 20 | | | | | | | | | |
| 1616 H16 | ● | ● | 16 | 16 | 100 | 20 | TNM. 1604.. | APL-01 | ALV-02-M6x17 | AATN-3-0025 | AAY-01 | - | - | - | |
| 2020 K16 | ● | ● | 20 | 20 | 125 | 25 | | | | | | | | | |
| 2525 M16 | ● | ● | 25 | 25 | 150 | 32 | | | | | | | | | |
| 3232 P16 | ● | ● | 32 | 32 | 170 | 40 | TNM. 2204.. | APL-02 | ALV-03-M8x19 | AATN-3-0015 | AAY-02 | ACK-5 | 1515-M4x11 | AAL-03-3 | |
| 2525 M22C | ● | ● | 25 | 25 | 150 | 32 | | | | | | | | | |
| 3232 P22C | ○ | ○ | 32 | 32 | 170 | 40 | | | | | | | | | |
| 4040 S27 | ○ | ○ | 40 | 40 | 250 | 50 | TNM. 2706.. | 07042709 | 07042710 | 07042701 | 07042711 | - | - | AAL-05-4 | |

R: Sağ/Right L: Sol/Left ● Stokta/In Stock ○ Stokta Yok/Non Stock Item

Sipariş Örneği/Ordering Example : 1 ad./pcs. PTG NR 1010 E11

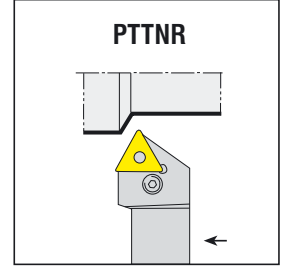
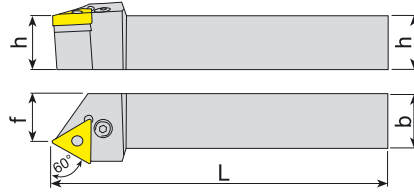

| Takım Kodu Ordering Code | Stok Stock | | Takım Ölçüleri (mm) Dimension (mm) | | | | Kesici Uç Insert | Yedek Parçaları Spare Parts | | | | | | |
|-----------------------------|---------------|---|---------------------------------------|----|-----|------|---------------------|--------------------------------|-------------------------------|-----------------|-----------------------------|------------------------------|-----------------------------|----------------------|
| | R | L | h | b | L | f | | Levyeye Lever | Levyeye Vidası Lever Screw | Altılık Shim | Altılık Yayı Shim Spring | Baskı Parçası Wedge Clamp | Baskı Vidası Clamp Screw | Anahtar Allen Key |
| | | | | | | | | | | | | | | |
| PTTNR/L 1616 H16 | ● | ● | 16 | 16 | 100 | 13 | | | | | | | | |
| 2020 K16 | ● | ● | 20 | 20 | 125 | 17 | | | | | | | | |
| 2525 M16 | ● | ● | 25 | 25 | 150 | 21.5 | | | | | | | | |
| 3232 P16 | ● | ● | 32 | 32 | 170 | 31 | | | | | | | | |
| 2525 M22C | ● | ● | 25 | 25 | 150 | 20.5 | | | | | | | | |
| 3232 P22C | ● | ● | 32 | 32 | 170 | 29 | | | | | | | | |

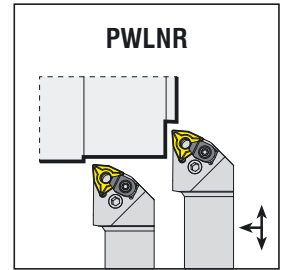
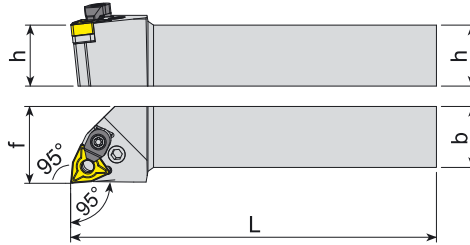

| Takım Kodu Ordering Code | Stok Stock | | Takım Ölçüleri (mm) Dimension (mm) | | | | Kesici Uç Insert | Yedek Parçaları Spare Parts | | | | | | |
|-----------------------------|---------------|---|---------------------------------------|----|-----|----|---------------------|--------------------------------|-------------------------------|-----------------|-----------------------------|------------------------------|-----------------------------|----------------------|
| | R | L | h | b | L | f | | Levyeye Lever | Levyeye Vidası Lever Screw | Altılık Shim | Altılık Yayı Shim Spring | Baskı Parçası Wedge Clamp | Baskı Vidası Clamp Screw | Anahtar Allen Key |
| | | | | | | | | | | | | | | |
| PWLNR/L 1616 H06 | ● | ● | 16 | 16 | 100 | 20 | | | | | | | | |
| 2020 K06 | ● | ● | 20 | 20 | 125 | 25 | | | | | | | | |
| 2525 M06 | ● | ● | 25 | 25 | 150 | 32 | | | | | | | | |
| 3232 P06 | ○ | ○ | 32 | 32 | 170 | 40 | | | | | | | | |
| 1616 H08 | ● | ● | 16 | 16 | 100 | 20 | | | | | | | | |
| 2020 K08C | ● | ● | 20 | 20 | 125 | 25 | | | | | | | | |
| 2525 M08C | ● | ● | 25 | 25 | 150 | 32 | | | | | | | | |
| 3232 P08C | ● | ● | 32 | 32 | 170 | 40 | | | | | | | | |

R: Sağ/Right L: Sol/Left ● Stokta/In Stock ○ Stokta Yok/Non Stock Item

Sipariş Örneği/Ordering Example : 1 ad./pcs. PTTNR 1616 H16

konusulan
the spoken kalite...
quality...





*konusulan
the spoken kalite...
quality...*

C-SİSTEM

C-SİSTEM DIŞ TORNA KATERLERİ

C-SYSTEM EXTERNAL TURNING TOOLHOLDERS



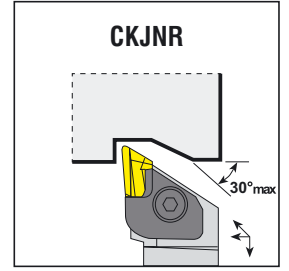
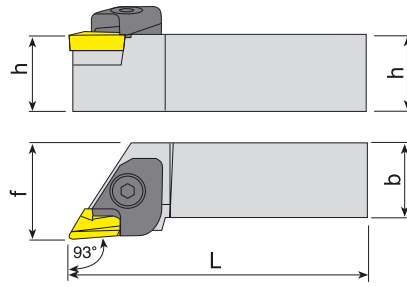

| Takım Kodu Ordering Code | Stok Stock | | Takım Ölçüleri (mm) Dimension (mm) | | | | Kesici Uç Insert | Yedek Parçaları Spare Parts | | | | | | | | | | | | | |
|-----------------------------|---------------|---|---------------------------------------|----|-----|----|---------------------|--------------------------------|-----------------------------|----------------|-----------------------------|---------------|--------------|----------------------|----------|--------------|----------|--------------|--------|---------|----------|
| | R | L | h | b | L | f | | Baskı Pabucu Wedge Clamp | Pabuç Vidası Clamp Screw | Altlık Shim | Altlık Vidası Shim Screw | Yay Spring | Pul Stamp | Anahtar Allen Key | | | | | | | |
| CKJNR/L 2020 K16 | ● | ● | 20 | 20 | 125 | 25 | KNUX 1604.. | | | | | | | | | | | | | | |
| 2525 M16 | ● | ● | 25 | 25 | 150 | 32 | | | | | | | | | ACK-01-R | AKV-06-M6x20 | AKS-16-R | AAV-01-M3x10 | AKY-02 | ABPL-01 | AAL-05-4 |
| 3232 P16 | ● | ● | 32 | 32 | 170 | 40 | | | | | | | | | ACK-02-L | | AKS-16-L | | | | |
| 4040 S16 | ● | ● | 40 | 40 | 250 | 50 | | | | | | | | | | | | | | | |

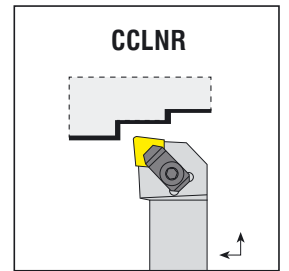
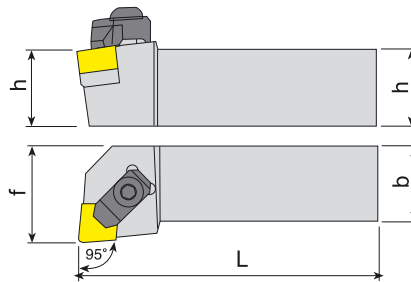

| Takım Kodu Ordering Code | Stok Stock | | Takım Ölçüleri (mm) Dimension (mm) | | | | Kesici Uç Insert | Yedek Parçaları Spare Parts | | | | | |
|-----------------------------|---------------|---|---------------------------------------|----|-----|----|---------------------|--------------------------------|-----------------------------|----------------|-----------------------------|----------------|----------------------|
| | R | L | h | b | L | f | | Baskı Pabucu Wedge Clamp | Pabuç Vidası Clamp Screw | Altlık Shim | Altlık Vidası Shim Screw | Sekman Ring | Anahtar Allen Key |
| CCLNR/L 2525 M1207C | ● | ● | 25 | 25 | 150 | 32 | CN.N 1207.. | | | | | | |
| 3232 P1207C | ● | ● | 32 | 32 | 170 | 40 | | | | | | | |

R: Sağ/Right L: Sol/Left ● Stokta/In Stock ○ Stokta Yok/Non Stock Item

Sipariş Örneği/Ordering Example : 1 ad./pcs. CCLNR 2525 M1207C

> C-SİSTEM SERAMİK UÇLAR İÇİN DİŞ TORNA KATERLERİ
C-SYSTEM EXTERNAL TURNING TOOLHOLDERS FOR CERAMIC INSERTS

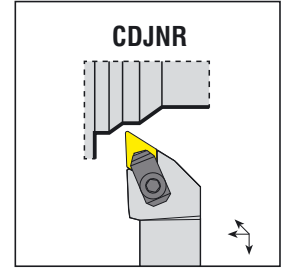
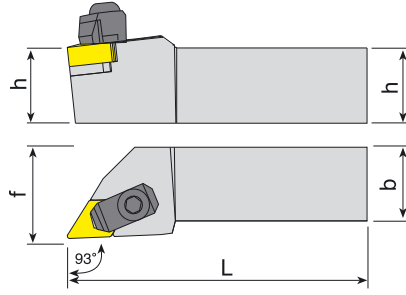

| Takım Kodu Ordering Code | Stok Stock | | Takım Ölçüleri (mm) Dimension (mm) | | | | Kesici Uç Insert | Yedek Parçaları Spare Parts | | | | | |
|--|---------------|---|---------------------------------------|----|-----|----|---------------------|--------------------------------|-----------------------------|----------------|-----------------------------|----------------|----------------------|
| | R | L | h | b | L | f | | Baskı Pabucu Wedge Clamp | Pabuç Vidası Clamp Screw | Altlık Shim | Altlık Vidası Shim Screw | Sekman Ring | Anahtar Allen Key |
| CDJNR/L 2525 M1507C 3232 P1507C | ● | ● | 25 | 25 | 150 | 32 | DN.N 1507.. | | | | | | |
| | ● | ● | 32 | 32 | 170 | 40 | | | | | | | |

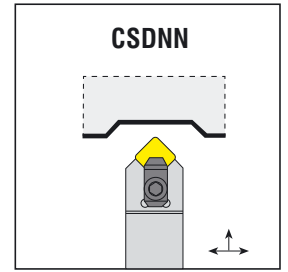
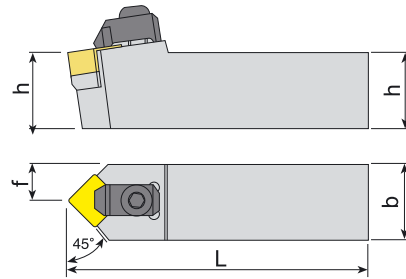

| Takım Kodu Ordering Code | Stok Stock | | Takım Ölçüleri (mm) Dimension (mm) | | | | Kesici Uç Insert | Yedek Parçaları Spare Parts | | | | | |
|--|---------------|---|---------------------------------------|----|-----|------|---------------------|--------------------------------|-----------------------------|----------------|-----------------------------|----------------|----------------------|
| | R | L | h | b | L | f | | Baskı Pabucu Wedge Clamp | Pabuç Vidası Clamp Screw | Altlık Shim | Altlık Vidası Shim Screw | Sekman Ring | Anahtar Allen Key |
| CSDNN 2525 M1207C 3232 P1207C | ● | ● | 25 | 25 | 150 | 12.5 | SN.N 1207.. | | | | | | |
| | ● | ● | 32 | 32 | 170 | 16 | | | | | | | |

R: Sağ/Right L: Sol/Left ● Stokta/In Stock ○ Stokta Yok/Non Stock Item

Sipariş Örneği/Ordering Example : 1 ad./pcs. CDJNR 2525 M1507C

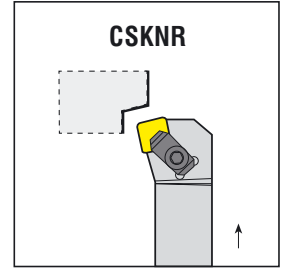
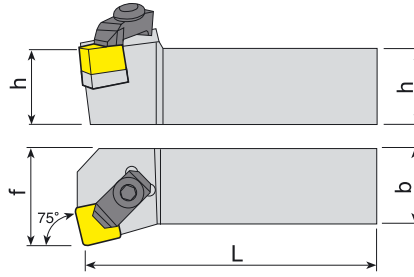

| Takım Kodu Ordering Code | Stok Stock | | Takım Ölçüleri (mm) Dimension (mm) | | | | Kesici Uç Insert | Yedek Parçaları Spare Parts | | | | | |
|-----------------------------|---------------|---|---------------------------------------|----|-----|----|---------------------|--------------------------------|-----------------------------|----------------|-----------------------------|----------------|----------------------|
| | R | L | h | b | L | f | | Baskı Pabucu Wedge Clamp | Pabuç Vidası Clamp Screw | Altlık Shim | Altlık Vidası Shim Screw | Sekman Ring | Anahtar Allen Key |
| CSKNR/L 2525 M1207C | ● | ● | 25 | 25 | 150 | 32 | SN.N 1207.. | ACK-13 | AKV-11-M8x29 | AASN-3-0004 | AAV-02-M5x12 | ACS-01 | AAL-05-4 |
| 3232 P1207C | ● | ○ | 32 | 32 | 170 | 40 | | | | | | | |

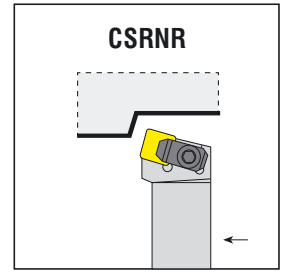
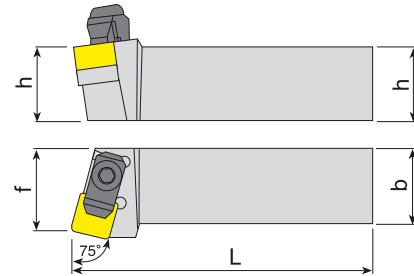

| Takım Kodu Ordering Code | Stok Stock | | Takım Ölçüleri (mm) Dimension (mm) | | | | Kesici Uç Insert | Yedek Parçaları Spare Parts | | | | | |
|-----------------------------|---------------|---|---------------------------------------|----|-----|----|---------------------|--------------------------------|-----------------------------|----------------|-----------------------------|----------------|----------------------|
| | R | L | h | b | L | f | | Baskı Pabucu Wedge Clamp | Pabuç Vidası Clamp Screw | Altlık Shim | Altlık Vidası Shim Screw | Sekman Ring | Anahtar Allen Key |
| CSRNR/L 2525 M1207C | ● | ● | 25 | 25 | 150 | 32 | SN.N 1207.. | ACK-13 | AKV-11-M8x29 | AASN-3-0004 | AAV-02-M5x12 | ACS-01 | AAL-05-4 |
| 3232 P1207C | ● | ○ | 32 | 32 | 170 | 40 | | | | | | | |

R: Sağ/Right L: Sol/Left ● Stokta/In Stock ○ Stokta Yok/Non Stock Item

Sipariş Örneği/Ordering Example : 1 ad./pcs. CSKNR 2525 M1207C

> C-SİSTEM SERAMİK UÇLAR İÇİN DİŞ TORNA KATERLERİ
C-SYSTEM EXTERNAL TURNING TOOLHOLDERS FOR CERAMIC INSERTS

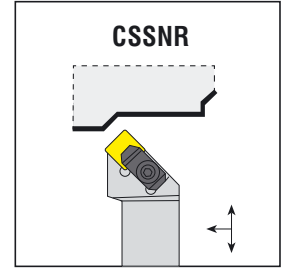
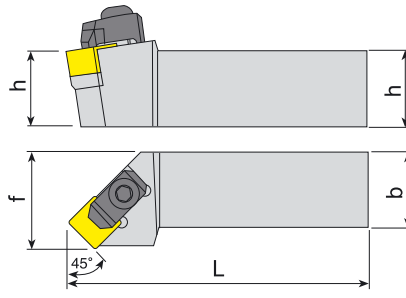

| Takım Kodu Ordering Code | Stok Stock | | Takım Ölçüleri (mm) Dimension (mm) | | | | Kesici Uç Insert | Yedek Parçaları Spare Parts | | | | | |
|-----------------------------|------------------------------------|---|---------------------------------------|----------|----------|------------|---------------------|--------------------------------|-----------------------------|----------------|-----------------------------|----------------|----------------------|
| | R | L | h | b | L | f | | Baskı Pabuçu Wedge Clamp | Pabuç Vidası Clamp Screw | Altlık Shim | Altlık Vidası Shim Screw | Sekman Ring | Anahtar Allen Key |
| | CSSNR/L 2525 M1207C 3232 P1207C | ● | ● | 25 32 | 25 32 | 150 170 | | 32 40 | SN.N 1207.. | ACK-13 | AKV-11-M8x29 | AASN-3-0004 | AAV-02-M5x12 |

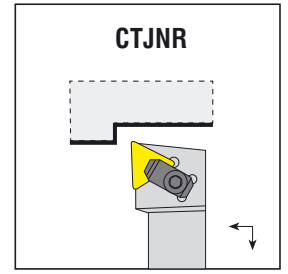
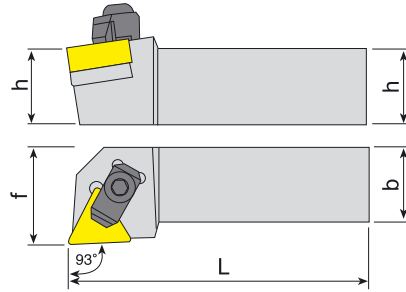

| Takım Kodu Ordering Code | Stok Stock | | Takım Ölçüleri (mm) Dimension (mm) | | | | Kesici Uç Insert | Yedek Parçaları Spare Parts | | | | | |
|-----------------------------|------------------------------------|---|---------------------------------------|----------|----------|------------|---------------------|--------------------------------|-----------------------------|----------------|-----------------------------|----------------|----------------------|
| | R | L | h | b | L | f | | Baskı Pabuçu Wedge Clamp | Pabuç Vidası Clamp Screw | Altlık Shim | Altlık Vidası Shim Screw | Sekman Ring | Anahtar Allen Key |
| | CTJNR/L 2525 M1607C 3232 P1607C | ● | ● | 25 32 | 25 32 | 150 170 | | 32 40 | TN.N 1607.. | ACK-14 | AKV-11-M8x29 | AATN-2-0002 | AAV-03-M5x12 |

R: Sağ/Right L: Sol/Left ● Stokta/In Stock ○ Stokta Yok/Non Stock Item

Sipariş Örneği/Ordering Example : 1 ad./pcs. CSSNR 2525 M1207C

S-SİSTEM

S-SİSTEM DIŞ TORNA KATERLERİ
S-SYSTEM EXTERNAL TURNING TOOLHOLDERS

*konusulan
the spoken kalite...
quality...*



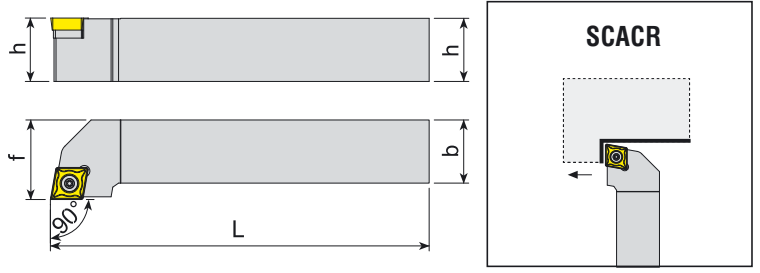

| Takım Kodu Ordering Code | Stok Stock | | Takım Ölçüleri (mm) Dimension (mm) | | | | Kesici Uç Insert | Yedek Parçaları Spare Parts | | | |
|-----------------------------|------------------|---|---------------------------------------|----|-----|----|---------------------|--------------------------------|---------------|----------------------------|--------------------------|
| | R | L | h | b | L | f | | Sıkma Vidası Screw | Altık Shim | Altık Vidası Shim Screw | Tork Anahtar Torx Key |
| | SCACR/L 0808 E06 | ● | ● | 08 | 08 | 70 | | 10 | CCM. 0602.. | 4008-M2.5x6 | - |
| 1010 E06 | ● | ● | 10 | 10 | 70 | 12 | | | | | |
| 1212 F09 | ● | ● | 12 | 12 | 80 | 16 | CCM. 09T3.. | 4015-M3.5x11 | - | - | 80-T15 |
| 1616 H09 | ● | ● | 16 | 16 | 100 | 20 | | | | | |
| 2020 K09 | ● | ● | 20 | 20 | 125 | 25 | | | | | |
| 2020 K12 | ● | ● | 20 | 20 | 125 | 25 | CCM. 1204.. | 1020-M4.5x16 | AACN-2-0001 | AAV-06-M3.5x11 | 80-T15 |
| 2525 M12 | ● | ● | 25 | 25 | 150 | 32 | | | | | |

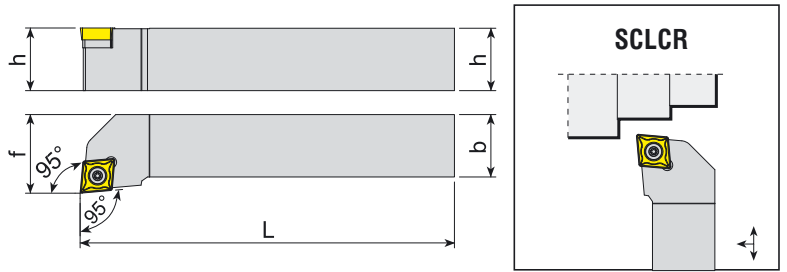
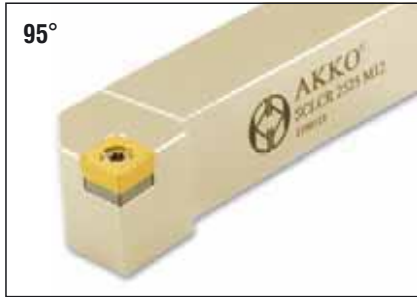

| Takım Kodu Ordering Code | Stok Stock | | Takım Ölçüleri (mm) Dimension (mm) | | | | Kesici Uç Insert | Yedek Parçaları Spare Parts | | | |
|-----------------------------|------------------|---|---------------------------------------|----|-----|----|---------------------|--------------------------------|---------------|----------------------------|--------------------------|
| | R | L | h | b | L | f | | Sıkma Vidası Screw | Altık Shim | Altık Vidası Shim Screw | Tork Anahtar Torx Key |
| | SCLCR/L 0808 E06 | ● | ● | 08 | 08 | 70 | | 10 | CCM. 0602.. | 4008-M2.5x6 | - |
| 1010 E06 | ● | ● | 10 | 10 | 70 | 12 | | | | | |
| 1212 F09 | ● | ● | 12 | 12 | 80 | 16 | CCM. 09T3.. | 4015-M3.5x11 | - | - | 80-T15 |
| 1616 H09 | ● | ● | 16 | 16 | 100 | 20 | | | | | |
| 2020 K09 | ● | ● | 20 | 20 | 125 | 25 | | | | | |
| 2020 K12 | ● | ● | 20 | 20 | 125 | 25 | CCM. 1204.. | 1020-M4.5x16 | AACN-2-0001 | AAV-06-M3.5x11 | 80-T15 |
| 2525 M12 | ● | ● | 25 | 25 | 150 | 32 | | | | | |

R: Sağ/Right L: Sol/Left ● Stokta/In Stock ○ Stokta Yok/Non Stock Item

Sipariş Örneği/Ordering Example : 1 ad./pcs. SCACR 0808 E06

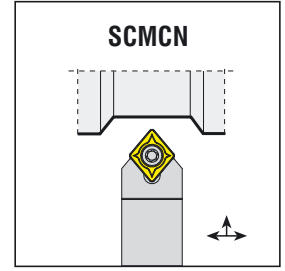
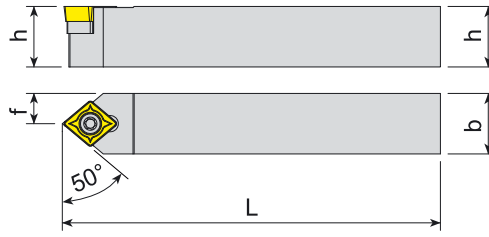

| Takım Kodu Ordering Code | Stok Stock | Takım Ölçüleri (mm) Dimension (mm) | | | | Kesici Uç Insert | Yedek Parçaları Spare Parts | | | |
|-----------------------------|---------------|---------------------------------------|----|-----|------|---------------------|--------------------------------|---------------|----------------------------|--------------------------|
| | | h | b | L | f | | Sıkma Vidası Screw | Altık Shim | Altık Vidası Shim Screw | Tork Anahtar Torx Key |
| SCMCN 0808 E06 | ● | 08 | 08 | 70 | 04 | CCM. 0602.. | 4008-M2.5x6 | - | - | 80-T08 |
| 1010 E06 | ● | 10 | 10 | 70 | 05 | | | | | |
| 1212 F09 | ● | 12 | 12 | 80 | 06 | CCM. 09T3.. | 4015-M3.5x11 | - | - | 80-T15 |
| 1616 H09 | ● | 16 | 16 | 100 | 08 | | | | | |
| 2020 K12 | ○ | 20 | 20 | 125 | 10 | CCM. 1204.. | 1020-M4.5x16 | AACN-2-0001 | AAV-06-M3.5x11 | 80-T20 |
| 2525 M12 | ○ | 25 | 25 | 150 | 12.5 | | | | | |

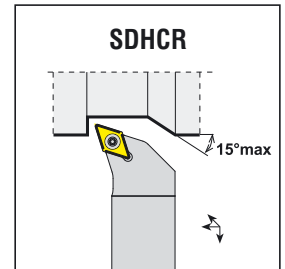
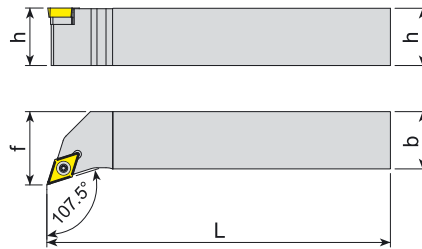

| Takım Kodu Ordering Code | Stok Stock | | Takım Ölçüleri (mm) Dimension (mm) | | | | Kesici Uç Insert | Yedek Parçaları Spare Parts | | | |
|-----------------------------|---------------|---|---------------------------------------|----|-----|----|---------------------|--------------------------------|---------------|----------------------------|--------------------------|
| | R | L | h | b | L | f | | Sıkma Vidası Screw | Altık Shim | Altık Vidası Shim Screw | Tork Anahtar Torx Key |
| SDHCR/L 0808 E07 | ● | ● | 08 | 08 | 70 | 10 | DCM. 0702.. | 4008-M2.5x6 | - | - | 80-T08 |
| 1010 E07 | ● | ● | 10 | 10 | 70 | 12 | | | | | |
| 1212 F07 | ● | ● | 12 | 12 | 80 | 16 | | | | | |
| 1616 H07 | ● | ● | 16 | 16 | 100 | 20 | | | | | |
| 1616 H11 | ● | ● | 16 | 16 | 100 | 20 | DCM. 11T3.. | 4015-M3.5x14 | AADN-2-0001 | AAV-06-M3.5x11 | 80-T15 |
| 2020 K11 | ● | ● | 20 | 20 | 125 | 25 | | | | | |
| 2525 M11 | ● | ● | 25 | 25 | 150 | 32 | | | | | |
| 3232 P11 | ● | ● | 32 | 32 | 170 | 40 | | | | | |

R: Sağ/Right L: Sol/Left ● Stokta/In Stock ○ Stokta Yok/Non Stock Item

Sipariş Örneği/Ordering Example : 1 ad./pcs. SCMCN 0808 E06

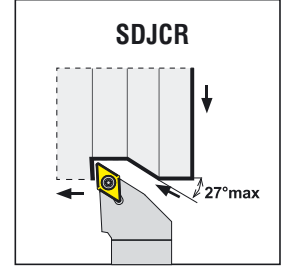
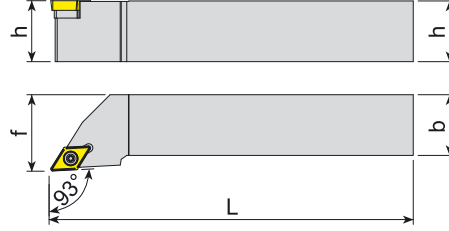

| Takım Kodu Ordering Code | Stok Stock | | Takım Ölçüleri (mm) Dimension (mm) | | | | Kesici Uç Insert | Yedek Parçaları Spare Parts | | | |
|-----------------------------|---------------|---|---------------------------------------|----|-----|----|---------------------|--------------------------------|---------------|----------------------------|--------------------------|
| | R | L | h | b | L | f | | Sıkma Vidası Screw | Altık Shim | Altık Vidası Shim Screw | Tork Anahtar Torx Key |
| SDJCR/L 0808 E07 | ● | ● | 08 | 08 | 70 | 10 | | | | | |
| 1010 E07 | ● | ● | 10 | 10 | 70 | 12 | | | | | |
| 1212 F07 | ● | ● | 12 | 12 | 80 | 16 | | | | | |
| 1616 H07 | ● | ● | 16 | 16 | 100 | 20 | | | | | |
| 1616 H11 | ● | ● | 16 | 16 | 100 | 20 | | | | | |
| 2020 K11 | ● | ● | 20 | 20 | 125 | 25 | | | | | |
| 2525 M11 | ● | ● | 25 | 25 | 150 | 32 | | | | | |
| 3232 P11 | ● | ● | 32 | 32 | 170 | 40 | | | | | |

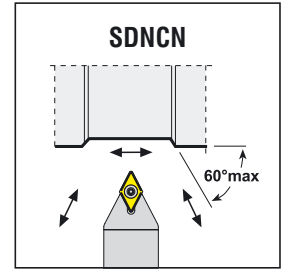
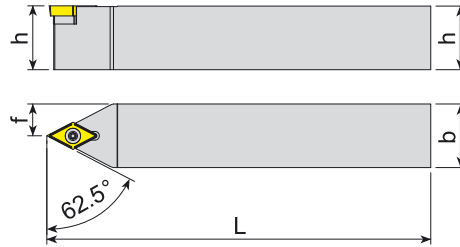

| Takım Kodu Ordering Code | Stok Stock | | Takım Ölçüleri (mm) Dimension (mm) | | | | Kesici Uç Insert | Yedek Parçaları Spare Parts | | | |
|-----------------------------|---------------|---|---------------------------------------|----|-----|------|---------------------|--------------------------------|---------------|----------------------------|--------------------------|
| | R | L | h | b | L | f | | Sıkma Vidası Screw | Altık Shim | Altık Vidası Shim Screw | Tork Anahtar Torx Key |
| SDNCN 0808 E07 | ● | ● | 08 | 08 | 70 | 4 | | | | | |
| 1010 E07 | ● | ● | 10 | 10 | 70 | 5 | | | | | |
| 1212 F07 | ● | ● | 12 | 12 | 80 | 6 | | | | | |
| 1616 H07 | ● | ● | 16 | 16 | 100 | 8 | | | | | |
| 1616 H11 | ● | ● | 16 | 16 | 100 | 8 | | | | | |
| 2020 K11 | ● | ● | 20 | 20 | 125 | 10 | | | | | |
| 2525 M11 | ● | ● | 25 | 25 | 150 | 12.5 | | | | | |
| 3232 P11 | ● | ● | 32 | 32 | 170 | 16 | | | | | |

R: Sağ/Right L: Sol/Left ● Stokta/In Stock ○ Stokta Yok/Non Stock Item

Sipariş Örneği/Ordering Example : 1 ad./pcs. SDJCR 0808 E07

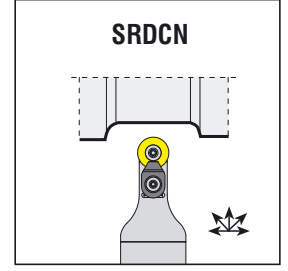
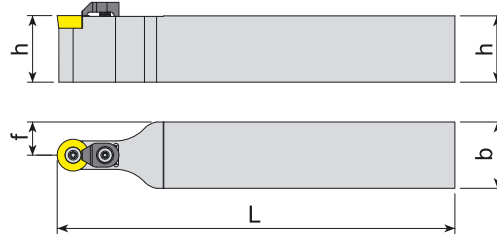

| Takım Kodu Ordering Code | Stok Stock | Takım Ölçüleri (mm) Dimension (mm) | | | | Kesici Uç Insert | Yedek Parçaları Spare Parts | | | | | |
|-----------------------------|---------------|---------------------------------------|----|-----|------|---------------------|--------------------------------|----------------|-----------------------------|------------------------------|-----------------------------|--------------------------|
| | | h | b | L | f | | Sıkma Vidası Screw | Aitlik Shim | Aitlik Vidası Shim Screw | Baskı Parçası Wedge Clamp | Baskı Vidası Clamp Screw | Tork Anahtar Torx Key |
| SRDCN 1616 H06 | ● | 16 | 16 | 100 | 8 | | | | | | | |
| 2020 K06 | ● | 20 | 20 | 125 | 10 | RC.T 0602.. | 4008-M2.5x6 | - | - | - | - | |
| 2525 M06 | ● | 25 | 25 | 150 | 12.5 | | | | | | | |
| 1616 H08C | ● | 16 | 16 | 100 | 8 | | | | | | | 80-T08 |
| 2020 K08C | ● | 20 | 20 | 125 | 10 | RC.T 0803.. | 1008-M3x8 | - | - | | | |
| 2525 M08C | ● | 25 | 25 | 150 | 12.5 | | | | | | | |
| 1616 H10C | ● | 16 | 16 | 100 | 8 | | | | | ACK-15 | 1015-M3.5x11 | |
| 2020 K10C | ● | 20 | 20 | 125 | 10 | | | | | | | |
| 2525 M10C | ● | 25 | 25 | 150 | 12.5 | RC.T 10T3.. | 4015-M3.5x11 | - | - | | | |
| 3232 P10C | ● | 32 | 32 | 170 | 16 | | | | | | | 80-T15 |
| 2020 K12C | ● | 20 | 20 | 125 | 10 | | | | | | | |
| 2525 M12C | ● | 25 | 25 | 150 | 12.5 | RC.T 1204.. | 4015-M3.5x11 | - | - | | | |
| 3232 P12C | ● | 32 | 32 | 170 | 16 | | | | | | | |
| 2525 M16C | ● | 25 | 25 | 150 | 12.5 | | | | | ACK-05 | 1515-M4x11 | |
| 3232 P16C | ● | 32 | 32 | 170 | 16 | RC.T 1605.. | 1020-M5x11 | - | - | | | |
| 2525 M20C | ● | 25 | 25 | 150 | 12.5 | | | | | | | 80-T20 |
| 3232 P20C | ● | 32 | 32 | 170 | 16 | RC.T 2006.. | 1420-M6x16 | - | - | | | |
| 3232 P25C | ● | 32 | 32 | 170 | 16 | RC.T 2507.. | 1520-M6x16 | | | ACK-09 | AAV-05-M6x15 | |
| 3232 P32C | ● | 32 | 32 | 170 | 16 | RC.T 3209.. | 1904-M8x1x20 | | | | | AAL-05-4 |

R: Sağ/Right L: Sol/Left ● Stokta/In Stock ○ Stokta Yok/Non Stock Item

Sipariş Örneği/Ordering Example : 1 ad./pcs. SRDCN 1616 H06



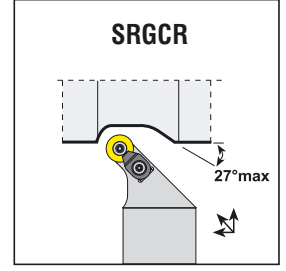
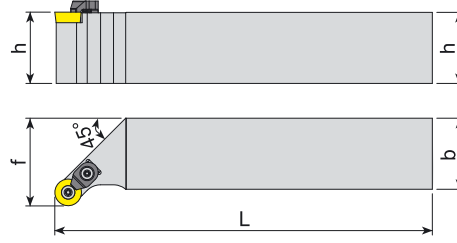

| Takım Kodu Ordering Code | Stok Stock | | Takım Ölçüleri (mm) Dimension (mm) | | | | Kesici Uç Insert | Yedek Parçaları Spare Parts | | | | | |
|-----------------------------|---------------|---|---------------------------------------|----|-----|----|---------------------|--------------------------------|-----------------|------------------------------|------------------------------|-----------------------------|--------------------------|
| | R | L | h | b | L | f | | Sıkma Vidası Screw | Altılık Shim | Altılık Vidası Shim Screw | Baskı Parçası Wedge Clamp | Baskı Vidası Clamp Screw | Tork Anahtar Torx Key |
| | | | | | | | | | | | | | |
| SRGCR/L 1616 H06 | ● | ○ | 16 | 16 | 100 | 20 | RC.T 0602.. | 4008-M2.5x6 | - | - | - | - | 80-T08 |
| 2020 K06 | ● | ○ | 20 | 20 | 125 | 25 | | | | | | | |
| 1616 H08C | ● | ● | 16 | 16 | 100 | 20 | RC.T 0803.. | 1008-M3x8 | - | - | ACK-15 | 1015-M3.5x11 | 80-T15 |
| 2020 K08C | ● | ● | 20 | 20 | 125 | 25 | | | | | | | |
| 2525 M08C | ● | ● | 25 | 25 | 150 | 32 | RC.T 10T3.. | 4015-M3.5x11 | - | - | ACK-05 | 1515-M4x11 | 80-T15 |
| 1616 H10C | ● | ● | 16 | 16 | 100 | 20 | | | | | | | |
| 2020 K10C | ● | ● | 20 | 20 | 125 | 25 | RC.T 1204.. | 4015-M3.5x11 | - | - | ACK-05 | 1515-M4x11 | 80-T15 |
| 2525 M10C | ● | ● | 25 | 25 | 150 | 32 | | | | | | | |
| 3232 P10C | ● | ● | 32 | 32 | 170 | 40 | RC.T 1204.. | 4015-M3.5x11 | - | - | ACK-05 | 1515-M4x11 | 80-T15 |
| 2020 K12C | ● | ● | 20 | 20 | 125 | 25 | | | | | | | |
| 2525 M12C | ● | ● | 25 | 25 | 150 | 32 | RC.T 1204.. | 4015-M3.5x11 | - | - | ACK-05 | 1515-M4x11 | 80-T15 |
| 3232 P12C | ● | ● | 32 | 32 | 170 | 40 | | | | | | | |

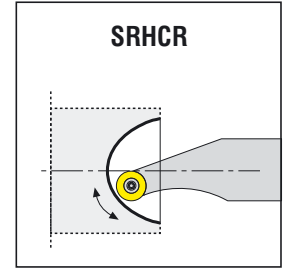
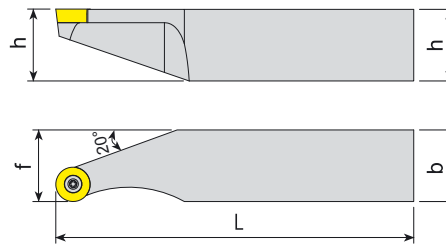

| Takım Kodu Ordering Code | Stok Stock | | Takım Ölçüleri (mm) Dimension (mm) | | | | Kesici Uç Insert | Yedek Parçaları Spare Parts | | | |
|-----------------------------|---------------|---|---------------------------------------|----|-----|----|---------------------|--------------------------------|-----------------|------------------------------|--------------------------|
| | R | L | h | b | L | f | | Sıkma Vidası Screw | Altılık Shim | Altılık Vidası Shim Screw | Tork Anahtar Torx Key |
| | | | | | | | | | | | |
| SRHCR/L 2525 K08 | ● | ● | 25 | 25 | 125 | 25 | RCM. 0803.. | 1008-M3x8 | - | - | 80-T08 |
| 2525 K10 | ● | ● | 25 | 25 | 125 | 25 | RCM. 10T3.. | 4015-M3.5x11 | - | - | 80-T15 |
| 2525 K12 | ● | ● | 25 | 25 | 125 | 25 | RCM. 1204.. | 1020-M5x11 | - | - | 80-T20 |
| 2525 K16 | ● | ● | 25 | 25 | 125 | 25 | RCM. 1606.. | 1020-M5x11 | - | - | 80-T20 |

R: Sağ/Right L: Sol/Left ● Stokta/In Stock ○ Stokta Yok/Non Stock Item

Sipariş Örneği/Ordering Example : 1 ad./pcs. SRGCR 1616 H16

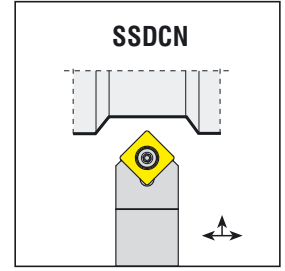
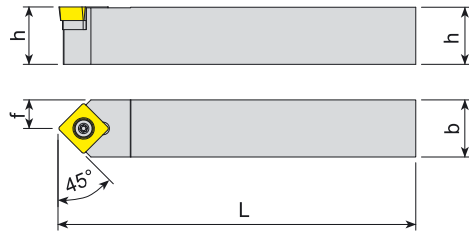

| Takım Kodu Ordering Code | Stok Stock | Takım Ölçüleri (mm) Dimension (mm) | | | | Kesici Uç Insert | Yedek Parçaları Spare Parts | | | |
|-----------------------------|---------------|---------------------------------------|----|-----|------|---------------------|--------------------------------|----------------|-----------------------------|--------------------------|
| | | h | b | L | f | | Sıkma Vidası Screw | Altlık Shim | Altlık Vidası Shim Screw | Tork Anahtar Torx Key |
| SSDCN 1212 F09 | ● | 12 | 12 | 80 | 6 | SC.T 09T3.. | 4015-M3.5x11 | - | - | 80-T15 |
| 1616 H09 | ● | 16 | 16 | 100 | 8 | | 4015-M3.5x14 | AASN-2-0001 | AAV-06-M3.5x11 | |
| 2020 K09 | ● | 20 | 20 | 125 | 10 | | 4020-M4.5x12 | AASN-2-0004 | AAV-10-M4.5x8 | |
| 1616 H12 | ● | 16 | 16 | 100 | 8 | SC.T 1204.. | 1020-M4.5x16 | AASN-2-0004 | AAV-07-M4.5x13 | 80-T20 |
| 2020 K12 | ● | 20 | 20 | 125 | 10 | | | | | |
| 2525 M12 | ● | 25 | 25 | 150 | 12.5 | | | | | |

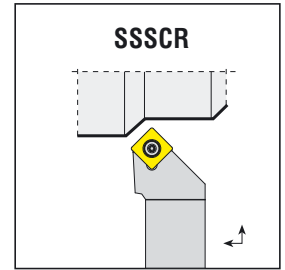
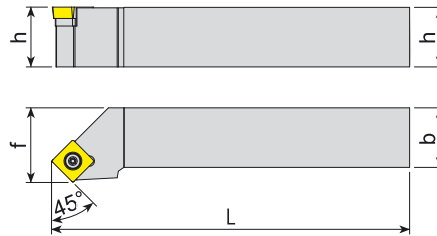

| Takım Kodu Ordering Code | Stok Stock | | Takım Ölçüleri (mm) Dimension (mm) | | | | Kesici Uç Insert | Yedek Parçaları Spare Parts | | | |
|-----------------------------|---------------|---|---------------------------------------|----|-----|----|---------------------|--------------------------------|----------------|-----------------------------|--------------------------|
| | R | L | h | b | L | f | | Sıkma Vidası Screw | Altlık Shim | Altlık Vidası Shim Screw | Tork Anahtar Torx Key |
| SSSCR/L 1212 F09 | ● | ● | 12 | 12 | 80 | 16 | SC.T 09T3.. | 4015-M3.5x11 | - | - | 80-T15 |
| 1616 H09 | ● | ● | 16 | 16 | 100 | 20 | | 4015-M3.5x14 | AASN-2-0001 | AAV-06-M3.5x11 | |
| 2020 K09 | ● | ● | 20 | 20 | 125 | 25 | | 4020-M4.5x12 | AASN-2-0004 | AAV-10-M4.5x8 | |
| 1616 H12 | ● | ● | 16 | 16 | 100 | 20 | SC.T 1204.. | 1020-M4.5x16 | AASN-2-0004 | AAV-07-M4.5x13 | 80-T20 |
| 2020 K12 | ● | ● | 20 | 20 | 125 | 25 | | | | | |
| 2525 M12 | ● | ● | 25 | 25 | 150 | 32 | | | | | |

R: Sağ/Right L: Sol/Left ● Stokta/In Stock ○ Stokta Yok/Non Stock Item

Sipariş Örneği/Ordering Example : 1 ad./pcs. SSDCN 1212 F09

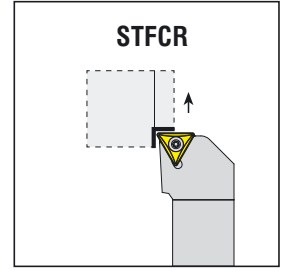
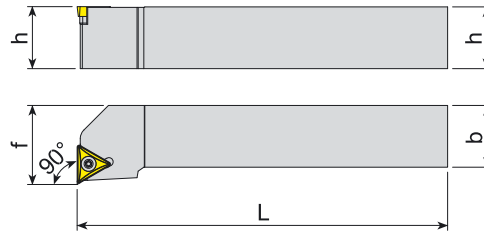

| Takım Kodu Ordering Code | Stok Stock | | Takım Ölçüleri (mm) Dimension (mm) | | | | Kesici Uç Insert | Yedek Parçaları Spare Parts | | | |
|-----------------------------|---------------|---|---------------------------------------|----|-----|----|---------------------|--------------------------------|---------------|----------------------------|--------------------------|
| | R | L | h | b | L | f | | Sıkma Vidası Screw | Altık Shim | Altık Vidası Shim Screw | Tork Anahtar Torx Key |
| STFCR/L 0808 E09 | ○ | ○ | 08 | 08 | 70 | 10 | TC.T 0902.. | 3007-M2.2x5 | - | - | 80-T07 |
| 1010 E09 | ● | ● | 10 | 10 | 70 | 12 | | | | | |
| 1212 F11 | ● | ● | 12 | 12 | 80 | 16 | TC.T 1102.. | 4008-M2.5x6 | - | - | 80-T08 |
| 1616 H11 | ● | ● | 16 | 16 | 100 | 20 | | | | | |
| 1616 H16 | ● | ● | 16 | 16 | 100 | 20 | TC.T 16T3.. | 4015-M3.5x14 | AATN-2-0001 | AAV-06-M3.5x11 | 80-T15 |
| 2020 K16 | ● | ● | 20 | 20 | 125 | 25 | | | | | |
| 2525 M16 | ● | ● | 25 | 25 | 150 | 32 | | | | | |
| 3232 P16 | ○ | ○ | 32 | 32 | 170 | 40 | | | | | |

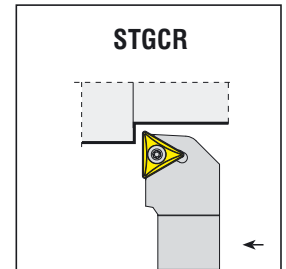
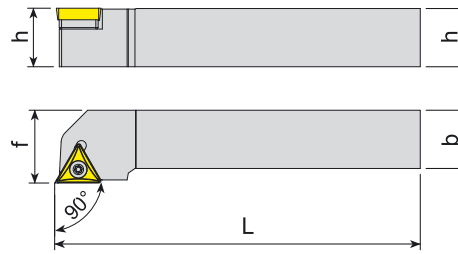

| Takım Kodu Ordering Code | Stok Stock | | Takım Ölçüleri (mm) Dimension (mm) | | | | Kesici Uç Insert | Yedek Parçaları Spare Parts | | | |
|-----------------------------|---------------|---|---------------------------------------|----|-----|----|---------------------|--------------------------------|---------------|----------------------------|--------------------------|
| | R | L | h | b | L | f | | Sıkma Vidası Screw | Altık Shim | Altık Vidası Shim Screw | Tork Anahtar Torx Key |
| STGCR/L 0808 E09 | ● | ● | 08 | 08 | 70 | 10 | TC.T 0902.. | 3007-M2.2x5 | - | - | 80-T07 |
| 1010 E09 | ● | ● | 10 | 10 | 70 | 12 | | | | | |
| 1212 F11 | ● | ● | 12 | 12 | 80 | 16 | TC.T 1102.. | 4008-M2.5x6 | - | - | 80-T08 |
| 1616 H11 | ● | ● | 16 | 16 | 100 | 20 | | | | | |
| 1616 H16 | ○ | ○ | 16 | 16 | 100 | 20 | TC.T 16T3.. | 4015-M3.5x14 | AATN-2-0001 | AAV-06-M3.5x11 | 80-T15 |
| 2020 K16 | ● | ● | 20 | 20 | 125 | 25 | | | | | |
| 2525 M16 | ● | ● | 25 | 25 | 150 | 32 | | | | | |
| 3232 P16 | ● | ● | 32 | 32 | 170 | 40 | | | | | |

R: Sağ/Right L: Sol/Left ● Stokta/In Stock ○ Stokta Yok/Non Stock Item

Sipariş Örneği/Ordering Example : 1 ad./pcs. STFCR 0808 E09

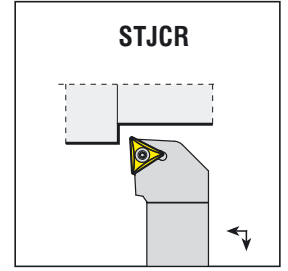
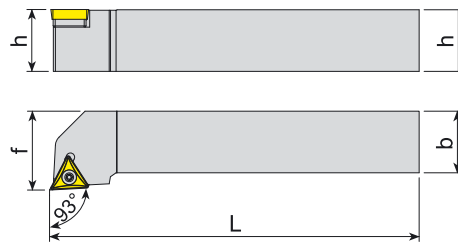

| Takım Kodu Ordering Code | Stok Stock | | Takım Ölçüleri (mm) Dimension (mm) | | | | Kesici Uç Insert | Yedek Parçaları Spare Parts | | | |
|-----------------------------|---------------|---|---------------------------------------|----|-----|----|---------------------|--------------------------------|---------------|----------------------------|--------------------------|
| | R | L | h | b | L | f | | Sıkma Vidası Screw | Altık Shim | Altık Vidası Shim Screw | Tork Anahtar Torx Key |
| | | | | | | | | | | | |
| STJCR/L 0808 E09 | ● | ● | 08 | 08 | 70 | 10 | TC.T 0902.. | 3007-M2.2x5 | - | - | 80-T07 |
| 1010 E09 | ● | ● | 10 | 10 | 70 | 12 | | | | | |
| 1212 F11 | ● | ● | 12 | 12 | 80 | 16 | TC.T 1102.. | 4008-M2.5x6 | - | - | 80-T08 |
| 1616 H11 | ● | ● | 16 | 16 | 100 | 20 | | | | | |
| 1616 H16 | ● | ● | 16 | 16 | 100 | 20 | TC.T 16T3.. | 4015-M3.5x14 | AATN-2-0001 | AAV-06-M3.5x11 | 80-T15 |
| 2020 K16 | ● | ● | 20 | 20 | 125 | 25 | | | | | |
| 2525 M16 | ● | ● | 25 | 25 | 150 | 32 | | | | | |
| 3232 P16 | ● | ● | 32 | 32 | 170 | 40 | | | | | |

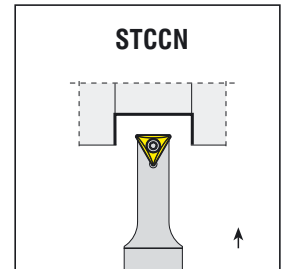
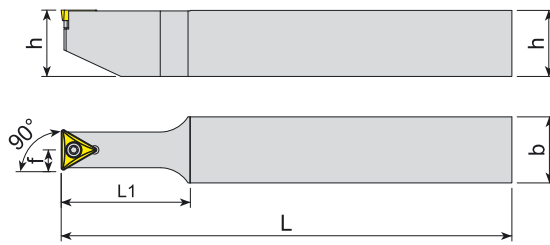

| Takım Kodu Ordering Code | Stok Stock | | Takım Ölçüleri (mm) Dimension (mm) | | | | | Kesici Uç Insert | Yedek Parçaları Spare Parts | | | |
|-----------------------------|---------------|---|---------------------------------------|----|-----|------|------|---------------------|--------------------------------|---------------|----------------------------|--------------------------|
| | R | L | h | b | L | f | L1 | | Sıkma Vidası Screw | Altık Shim | Altık Vidası Shim Screw | Tork Anahtar Torx Key |
| | | | | | | | | | | | | |
| STCCN 2020 L11 | ● | | 20 | 20 | 140 | 10 | 30 | TC.T 1102.. | 4008-M2.5x6 | - | - | 80-T08 |
| 1616 K16 | ● | | 16 | 16 | 125 | 8 | 24 | | | | | |
| 2020 M16 | ● | | 20 | 20 | 150 | 10 | 30 | TC.T 16T3.. | 4015-M3.5x14 | AATN-2-0001 | AAV-06-M3.5x11 | 80-T15 |
| 2525 P16 | ● | | 25 | 25 | 170 | 12.5 | 37.5 | | | | | |
| 3232 R16 | ● | | 32 | 32 | 200 | 16 | 48 | | | | | |
| 2525 P22 | ● | | 25 | 25 | 170 | 12.5 | 37.5 | | | | | |
| | | | | | | | | TC.T 2204.. | 4020-M4.5x12 | - | - | 80-T20 |

R: Sağ/Right L: Sol/Left ● Stokta/In Stock ○ Stokta Yok/Non Stock Item

Sipariş Örneği/Ordering Example : 1 ad./pcs. STJCR 0808 E09

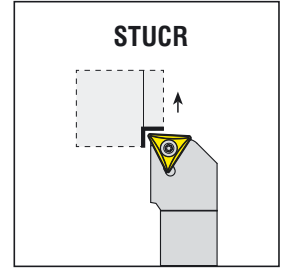
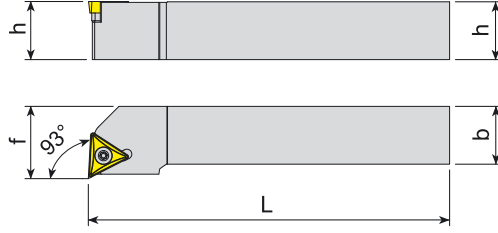

| Takım Kodu Ordering Code | Stok Stock | | Takım Ölçüleri (mm) Dimension (mm) | | | | Kesici Uç Insert | Yedek Parçaları Spare Parts | | | |
|-----------------------------|---------------|---|---------------------------------------|----|-----|----|---------------------|--------------------------------|---------------|----------------------------|--------------------------|
| | R | L | h | b | L | f | | Sıkma Vidası Screw | Altık Shim | Altık Vidası Shim Screw | Tork Anahtar Torx Key |
| | | | | | | | | | | | |
| STUCR/L 0808 E09 | ● | ● | 08 | 08 | 70 | 10 | | | | | 80-T07 |
| 1010 E09 | ● | ● | 10 | 10 | 70 | 12 | | | | | |
| 1212 F11 | ● | ● | 12 | 12 | 80 | 16 | | | | | |
| 1616 H11 | ● | ● | 16 | 16 | 100 | 20 | | | | | 80-T08 |
| 1616 H16 | ○ | ○ | 16 | 16 | 100 | 20 | | | | | |
| 2020 K16 | ● | ● | 20 | 20 | 125 | 25 | | | | | 80-T15 |
| 2525 M16 | ● | ● | 25 | 25 | 150 | 32 | | | | | |
| 3232 P16 | ● | ● | 32 | 32 | 170 | 40 | | | | | |

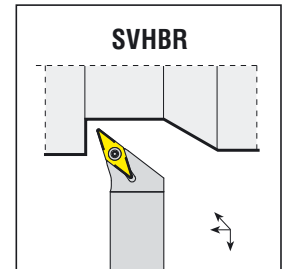
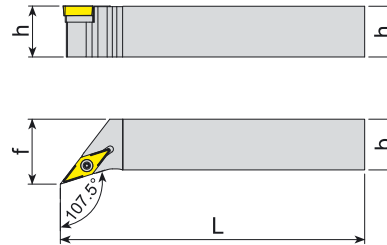

| Takım Kodu Ordering Code | Stok Stock | | Takım Ölçüleri (mm) Dimension (mm) | | | | Kesici Uç Insert | Yedek Parçaları Spare Parts | | | |
|-----------------------------|---------------|---|---------------------------------------|----|-----|----|---------------------|--------------------------------|---------------|----------------------------|--------------------------|
| | R | L | h | b | L | f | | Sıkma Vidası Screw | Altık Shim | Altık Vidası Shim Screw | Tork Anahtar Torx Key |
| | | | | | | | | | | | |
| SVHBR/L 1212 F11 | ● | ● | 12 | 12 | 80 | 16 | | | | | 80-T08 |
| 1616 H11 | ● | ● | 16 | 16 | 100 | 20 | | | | | |
| 2020 K11 | ● | ● | 20 | 20 | 125 | 25 | | | | | |
| 2020 K16 | ● | ● | 20 | 20 | 125 | 25 | | | | | 80-T15 |
| 2525 M16 | ● | ● | 25 | 25 | 150 | 32 | | | | | |
| 3232 P16 | ● | ● | 32 | 32 | 170 | 40 | | | | | |

R: Sağ/Right L: Sol/Left ● Stokta/In Stock ○ Stokta Yok/Non Stock Item

Sipariş Örneği/Ordering Example : 1 ad./pcs. STUCR 0808 E09

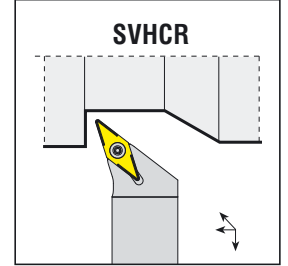
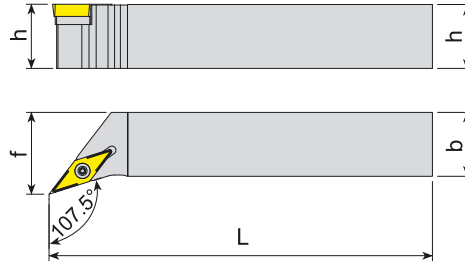

| Takım Kodu Ordering Code | Stok Stock | | Takım Ölçüleri (mm) Dimension (mm) | | | | Kesici Uç Insert | Yedek Parçaları Spare Parts | | | |
|-----------------------------|---------------|---|---------------------------------------|----|-----|----|---------------------|--------------------------------|---------------|----------------------------|--------------------------|
| | R | L | h | b | L | f | | Sıkma Vidası Screw | Altık Shim | Altık Vidası Shim Screw | Tork Anahtar Torx Key |
| SVHCR/L 1212 F11 | ● | ● | 12 | 12 | 80 | 16 | | | | | |
| 1616 H11 | ● | ● | 16 | 16 | 100 | 20 | | | | | |
| 2020 K11 | ● | ● | 20 | 20 | 125 | 25 | | | | | |
| 2020 K16 | ● | ● | 20 | 20 | 125 | 25 | | | | | |
| 2525 M16 | ● | ● | 25 | 25 | 150 | 32 | | | | | |
| 3232 P16 | ● | ● | 32 | 32 | 170 | 40 | | | | | |

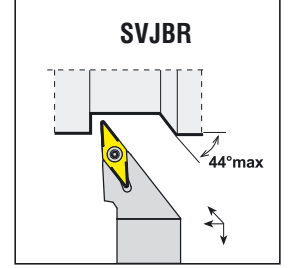
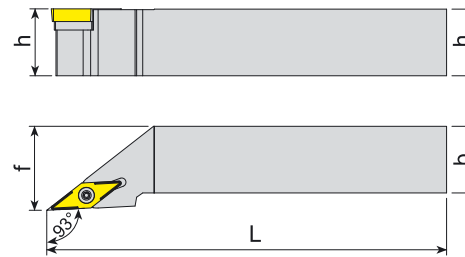

| Takım Kodu Ordering Code | Stok Stock | | Takım Ölçüleri (mm) Dimension (mm) | | | | Kesici Uç Insert | Yedek Parçaları Spare Parts | | | |
|-----------------------------|---------------|---|---------------------------------------|----|-----|----|---------------------|--------------------------------|---------------|----------------------------|--------------------------|
| | R | L | h | b | L | f | | Sıkma Vidası Screw | Altık Shim | Altık Vidası Shim Screw | Tork Anahtar Torx Key |
| SVJBR/L 1212 F11 | ● | ● | 12 | 12 | 80 | 16 | | | | | |
| 1616 H11 | ● | ● | 16 | 16 | 100 | 20 | | | | | |
| 2020 K11 | ● | ● | 20 | 20 | 125 | 25 | | | | | |
| 1616 H16 | ● | ● | 16 | 16 | 100 | 20 | | | | | |
| 2020 K16 | ● | ● | 20 | 20 | 125 | 25 | | | | | |
| 2525 M16 | ● | ● | 25 | 25 | 150 | 32 | | | | | |
| 3232 P16 | ● | ● | 32 | 32 | 170 | 40 | | | | | |

R: Sağ/Right L: Sol/Left ● Stokta/In Stock ○ Stokta Yok/Non Stock Item

Sipariş Örneği/Ordering Example : 1 ad./pcs. SVHCR 1212 F11

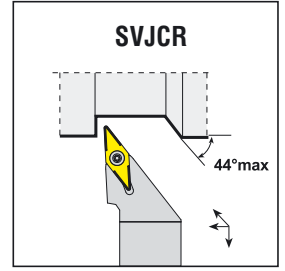
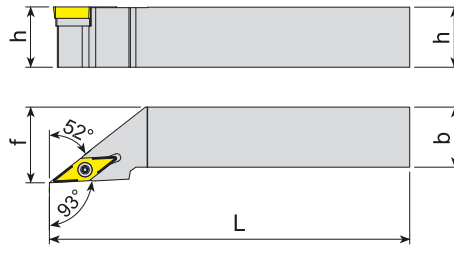

| Takım Kodu Ordering Code | Stok Stock | | Takım Ölçüleri (mm) Dimension (mm) | | | | Kesici Uç Insert | Yedek Parçaları Spare Parts | | | |
|-----------------------------|---------------|---|---------------------------------------|----|-----|----|---------------------|--------------------------------|---------------|----------------------------|--------------------------|
| | R | L | h | b | L | f | | Sıkma Vidası Screw | Altık Shim | Altık Vidası Shim Screw | Tork Anahtar Torx Key |
| SVJCR/L 1212 F11 | ● | ● | 12 | 12 | 80 | 16 | VC.T 1103.. | 4008-M2.5x6 | - | - | 80-T08 |
| 1616 H11 | ● | ● | 16 | 16 | 100 | 20 | | | | | |
| 2020 K11 | ● | ● | 20 | 20 | 125 | 25 | | | | | |
| 1212 F16 | ● | ○ | 12 | 12 | 80 | 16 | VC.T 1604.. | 4015-M3.5x14 | AAVN-2-0002 | AAV-06-M3.5x11 | 80-T15 |
| 2020 K16 | ● | ● | 20 | 20 | 125 | 25 | | | | | |
| 2525 M16 | ● | ● | 25 | 25 | 150 | 32 | | | | | |
| 3232 P16 | ● | ● | 32 | 32 | 170 | 40 | | | | | |

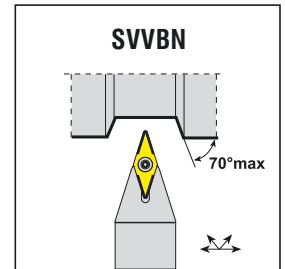
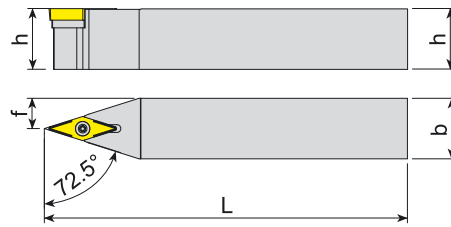

| Takım Kodu Ordering Code | Stok Stock | | Takım Ölçüleri (mm) Dimension (mm) | | | | Kesici Uç Insert | Yedek Parçaları Spare Parts | | | |
|-----------------------------|---------------|---|---------------------------------------|----|-----|------|---------------------|--------------------------------|---------------|----------------------------|--------------------------|
| | R | L | h | b | L | f | | Sıkma Vidası Screw | Altık Shim | Altık Vidası Shim Screw | Tork Anahtar Torx Key |
| SVVBN 1212 F11 | ● | | 12 | 12 | 80 | 06 | VBM. 1103.. | 4008-M2.5x6 | - | - | 80-T08 |
| 1616 H11 | ● | | 16 | 16 | 100 | 08 | | | | | |
| 2020 K11 | ● | | 20 | 20 | 125 | 10 | | | | | |
| 2020 K16 | ● | | 20 | 20 | 125 | 10 | VBM. 1604.. | 4015-M3.5x14 | AAVN-2-0002 | AAV-06-M3.5x11 | 80-T15 |
| 2525 M16 | ● | | 25 | 25 | 150 | 12.5 | | | | | |
| 3232 P16 | ● | | 32 | 32 | 170 | 16 | | | | | |

R: Sağ/Right L: Sol/Left ● Stokta/In Stock ○ Stokta Yok/Non Stock Item

Sipariş Örneği/Ordering Example : 1 ad./pcs. SVJCR 1212 F11

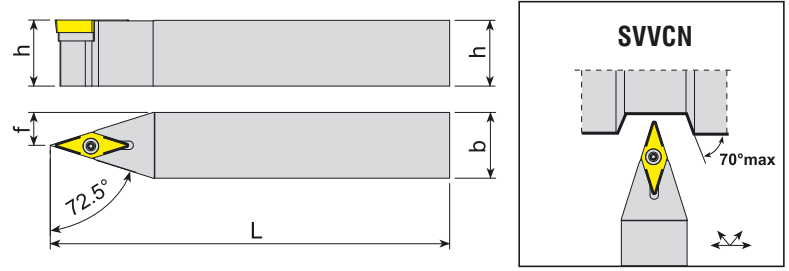

| Takım Kodu Ordering Code | Stok Stock | Takım Ölçüleri (mm) Dimension (mm) | | | | Kesici Uç Insert | Yedek Parçaları Spare Parts | | | |
|-----------------------------|---------------|---------------------------------------|----|-----|------|---------------------|--------------------------------|-----------------|------------------------------|--------------------------|
| | | h | b | L | f | | Sıkma Vidası Screw | Altılık Shim | Altılık Vidası Shim Screw | Tork Anahtar Torx Key |
| SVVCN 1212 F11 | ● | 12 | 12 | 80 | 06 | | | | | |
| 1616 H11 | ● | 16 | 16 | 100 | 08 | | | | | |
| 2020 K11 | ● | 20 | 20 | 125 | 10 | | | | | |
| 2020 K16 | ● | 20 | 20 | 125 | 10 | | | | | |
| 2525 M16 | ● | 25 | 25 | 150 | 12.5 | | | | | |
| 3232 P16 | ● | 32 | 32 | 170 | 16 | | | | | |

S-SİSTEM İSVEÇ TİPİ KAYAR OTOMAT MAKİNA TAKIMLARI
S-SYSTEM TOOLS FOR SWISS TYPE SLIDING AUTOMATIC LATHES

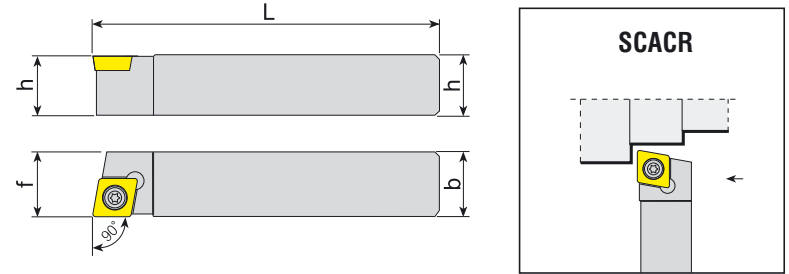

| Takım Kodu Ordering Code | Stok Stock | | Takım Ölçüleri (mm) Dimension (mm) | | | | Kesici Uç Insert | Yedek Parçaları Spare Parts | | | |
|-----------------------------|---------------|---|---------------------------------------|----|-----|----|---------------------|--------------------------------|-----------------|------------------------------|--------------------------|
| | R | L | h | b | L | f | | Sıkma Vidası Screw | Altılık Shim | Altılık Vidası Shim Screw | Tork Anahtar Torx Key |
| SCACR/L 0808 X06-S | ○ | ○ | 08 | 08 | 115 | 08 | | | | | |
| 1010 K06-S | ○ | ○ | 10 | 10 | 125 | 10 | | | | | |
| 1212 G06-S | ○ | ○ | 12 | 12 | 90 | 12 | | | | | |
| 1212 K06-S | ○ | ○ | 12 | 12 | 125 | 12 | | | | | |
| 1616 F06-S | ○ | ○ | 16 | 16 | 75 | 16 | | | | | |
| 1616 K06-S | ○ | ○ | 16 | 16 | 125 | 16 | | | | | |
| 1212 G09-S | ○ | ○ | 12 | 12 | 90 | 12 | | | | | |
| 1212 K09-S | ● | ● | 12 | 12 | 125 | 12 | | | | | |
| 1616 F09-S | ○ | ○ | 16 | 16 | 75 | 16 | | | | | |
| 1616 K09-S | ● | ● | 16 | 16 | 125 | 16 | | | | | |
| 2020 K09-S | ● | ● | 20 | 20 | 125 | 20 | | | | | |

R: Sağ/Right L: Sol/Left ● Stokta/In Stock ○ Stokta Yok/Non Stock Item

Sipariş Örneği/Ordering Example : 1 ad./pcs. SCACR 1010 K06-S

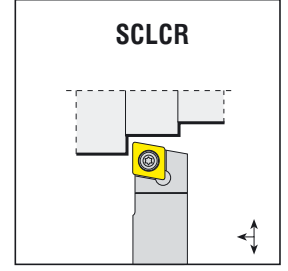
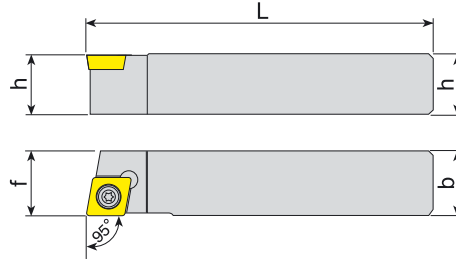

| Takım Kodu Ordering Code | Stok Stock | | Takım Ölçüleri (mm) Dimension (mm) | | | | Kesici Uç Insert | Yedek Parçaları Spare Parts | | | |
|-----------------------------|---------------------------|---|---------------------------------------|----|-----|-----|---------------------|--------------------------------|---------------|----------------------------|--------------------------|
| | R | L | h | b | L | f | | Sıkma Vidası Screw | Altık Shim | Altık Vidası Shim Screw | Tork Anahtar Torx Key |
| | SCLCR/L 0808 X06-S | ● | ○ | 08 | 08 | 115 | | 08 | CCM. 0602.. | 4008-M2.5x6 | - |
| 1010 K06-S | ● | ○ | 10 | 10 | 125 | 10 | | | | | |
| 1212 G06-S | ● | ○ | 12 | 12 | 90 | 12 | | | | | |
| 1212 K06-S | ● | ○ | 12 | 12 | 125 | 12 | | | | | |
| 1616 F06-S | ● | ○ | 16 | 16 | 75 | 16 | | | | | |
| 1616 K06-S | ● | ○ | 16 | 16 | 125 | 16 | | | | | |
| 1212 G09-S | ● | ○ | 12 | 12 | 90 | 12 | CCM. 09T3.. | 4015-M3.5x11 | - | - | 80-T15 |
| 1212 K09-S | ● | ○ | 12 | 12 | 125 | 12 | | | | | |
| 1616 F09-S | ● | ○ | 16 | 16 | 75 | 16 | | | | | |
| 1616 K09-S | ● | ○ | 16 | 16 | 125 | 16 | | | | | |
| 2020 K09-S | ● | ○ | 20 | 20 | 125 | 20 | | | | | |

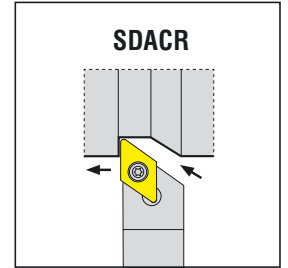
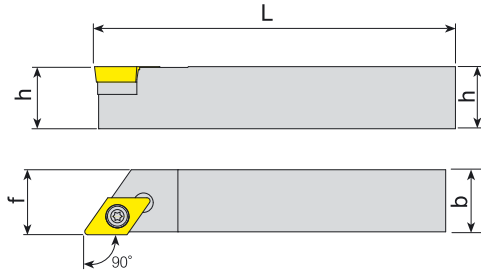

| Takım Kodu Ordering Code | Stok Stock | | Takım Ölçüleri (mm) Dimension (mm) | | | | Kesici Uç Insert | Yedek Parçaları Spare Parts | | | |
|-----------------------------|---------------------------|---|---------------------------------------|----|-----|-----|---------------------|--------------------------------|---------------|----------------------------|--------------------------|
| | R | L | h | b | L | f | | Sıkma Vidası Screw | Altık Shim | Altık Vidası Shim Screw | Tork Anahtar Torx Key |
| | SDACR/L 0808 X07-S | ○ | ○ | 08 | 08 | 115 | | 08 | DC.T 0702.. | 4008-M2.5x6 | - |
| 1010 K07-S | ● | ○ | 10 | 10 | 125 | 10 | | | | | |
| 1212 G07-S | ○ | ○ | 12 | 12 | 90 | 12 | | | | | |
| 1212 K07-S | ● | ○ | 12 | 12 | 125 | 12 | | | | | |
| 1616 F07-S | ○ | ○ | 16 | 16 | 75 | 16 | | | | | |
| 1616 K07-S | ● | ○ | 16 | 16 | 125 | 16 | | | | | |
| 1212 G11-S | ○ | ○ | 12 | 12 | 90 | 12 | DC.T 11T3.. | 4015-M3.5x11 | - | - | 80-T15 |
| 1212 K11-S | ● | ● | 12 | 12 | 125 | 12 | | | | | |
| 1616 F11-S | ○ | ○ | 16 | 16 | 75 | 16 | | | | | |
| 1616 K11-S | ● | ● | 16 | 16 | 125 | 16 | | | | | |
| 2020 K11-S | ● | ● | 20 | 20 | 125 | 20 | | | | | |

R: Sağ/Right L: Sol/Left ● Stokta/In Stock ○ Stokta Yok/Non Stock Item

Sipariş Örneği/Ordering Example : 1 ad./pcs. SCACR 1010 K06-S

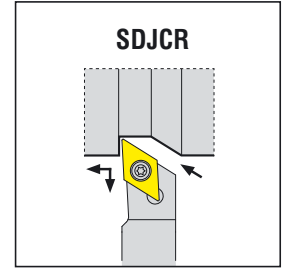
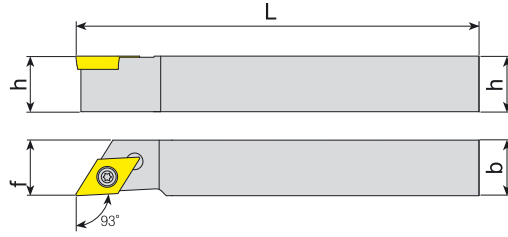



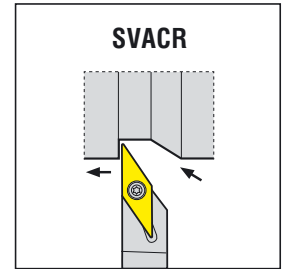
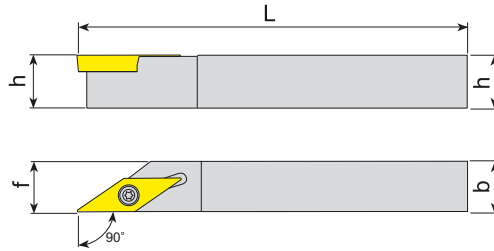

| Takım Kodu Ordering Code | Stok Stock | | | | | | Kesici Uç Insert | Yedek Parçaları Spare Parts | | | |
|-----------------------------|---------------------------------------|---|----|----|-----|----|---------------------|--------------------------------|----------------|-----------------------------|--------------------------|
| | Takım Ölçüleri (mm) Dimension (mm) | | | | | | | Sıkma Vidası Screw | Altlık Shim | Altlık Vidası Shim Screw | Tork Anahtar Torx Key |
| | R | L | h | b | L | f | | | | | |
| SDJCR/L 0808 X07-S | ● | ○ | 08 | 08 | 115 | 08 | | | | | 80-T08 |
| 1010 K07-S | ● | ○ | 10 | 10 | 125 | 10 | | | | | |
| 1212 G07-S | ● | ○ | 12 | 12 | 90 | 12 | | | | | |
| 1212 K07-S | ● | ○ | 12 | 12 | 125 | 12 | | | | | |
| 1616 F07-S | ● | ○ | 16 | 16 | 75 | 16 | | | | | |
| 1616 K07-S | ● | ○ | 16 | 16 | 125 | 16 | | | | | |
| 2020 K07-S | ● | ○ | 20 | 20 | 125 | 20 | | | | | |
| 1212 G11-S | ● | ○ | 12 | 12 | 90 | 12 | | | | | 80-T15 |
| 1212 K11-S | ● | ● | 12 | 12 | 125 | 12 | | | | | |
| 1616 F11-S | ● | ○ | 16 | 16 | 75 | 16 | | | | | |
| 1616 K11-S | ● | ○ | 16 | 16 | 125 | 16 | | | | | |
| 2020 K11-S | ● | ○ | 20 | 20 | 125 | 20 | | | | | |

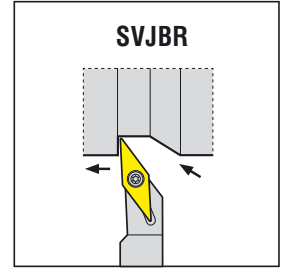
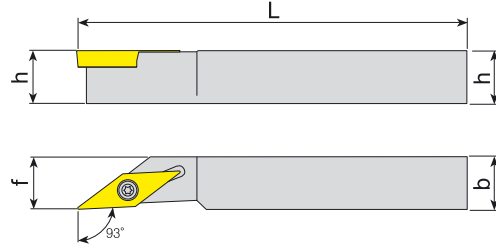





| Takım Kodu Ordering Code | Stok Stock | | | | | | Kesici Uç Insert | Yedek Parçaları Spare Parts | | | |
|-----------------------------|---------------------------------------|---|----|----|-----|----|---------------------|--------------------------------|----------------|-----------------------------|--------------------------|
| | Takım Ölçüleri (mm) Dimension (mm) | | | | | | | Sıkma Vidası Screw | Altlık Shim | Altlık Vidası Shim Screw | Tork Anahtar Torx Key |
| | R | L | h | b | L | f | | | | | |
| SVACR/L 0808 X11-S | ○ | ○ | 08 | 08 | 115 | 08 | | | | | 80-T08 |
| 1010 K11-S | ○ | ○ | 10 | 10 | 125 | 10 | | | | | |
| 1212 G11-S | ○ | ○ | 12 | 12 | 90 | 12 | | | | | |
| 1212 K11-S | ● | ○ | 12 | 12 | 125 | 12 | | | | | |
| 1616 F11-S | ○ | ○ | 16 | 16 | 75 | 16 | | | | | |
| 1616 K11-S | ● | ○ | 16 | 16 | 125 | 16 | | | | | |
| 2020 K11-S | ● | ○ | 20 | 20 | 125 | 20 | | | | | |

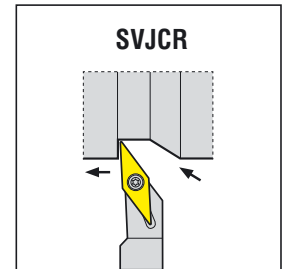
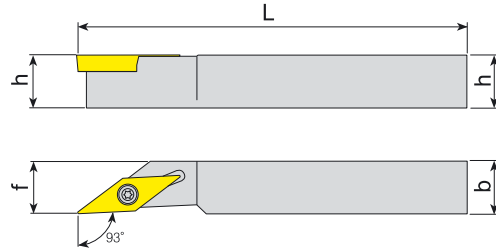

| Takım Kodu Ordering Code | Stok Stock | | Takım Ölçüleri (mm) Dimension (mm) | | | | Kesici Uç Insert | Yedek Parçaları Spare Parts | | | |
|-----------------------------|---------------|---|---------------------------------------|----|-----|----|---|---|---|---|---|
| | R | L | h | b | L | f | | Sıkma Vidası Screw | Altık Shim | Altık Vidası Shim Screw | Tork Anahtar Torx Key |
| SVJBR/L 1616 K11-S | ● | ● | 16 | 16 | 125 | 16 |  |  |  |  |  |
| | | | | | | | VBM. 1103.. | 4008-M2.5x6 | - | - | 80-T08 |



| Takım Kodu Ordering Code | Stok Stock | | Takım Ölçüleri (mm) Dimension (mm) | | | | Kesici Uç Insert | Yedek Parçaları Spare Parts | | | |
|-----------------------------|---------------|---|---------------------------------------|----|-----|----|---|---|---|---|---|
| | R | L | h | b | L | f | | Sıkma Vidası Screw | Altık Shim | Altık Vidası Shim Screw | Tork Anahtar Torx Key |
| SVJCR/L 0808 X11-S | ○ | ○ | 08 | 08 | 115 | 08 |  |  |  |  |  |
| 1010 K11-S | ○ | ○ | 10 | 10 | 125 | 10 | | | | | |
| 1212 G11-S | ○ | ○ | 12 | 12 | 90 | 12 | | | | | |
| 1212 K11-S | ● | ● | 12 | 12 | 125 | 12 | | | | | |
| 1616 F11-S | ○ | ○ | 16 | 16 | 75 | 16 | | | | | |
| 1616 K11-S | ○ | ○ | 16 | 16 | 125 | 16 | | | | | |
| 2020 K11-S | ○ | ○ | 20 | 20 | 125 | 20 | | | | | |
| | | | | | | | | | | | |

R: Sağ/Right L: Sol/Left ● Stokta/In Stock ○ Stokta Yok/Non Stock Item

Sipariş Örneği/Ordering Example : 1 ad./pcs. SVJBR 1616 K11-S

DELİK TORNA TAKIMLARI
INTERNAL TURNING TOOLHOLDERS





1 Takım Malzemesi / Type of Boring Bar

"A" Yekpare çelik gövde soğutma suyu kanallı / "A" Solid steel with coolant hole
 "E" Çelik başlıkla sert metal gövde ve soğutma suyu kanallı /
 "E" Carbide bar with fixed steel head and coolant hole
 "C" Karbür Şaft / "C" Carbide shank
 "S" Çelik Şaft / "S" Steel shank

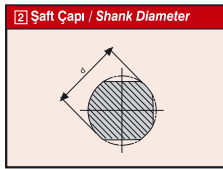

3 Şaft Boyu / Shank Length

| | | | |
|--------|---------|---------|-----------|
| A - 32 | H - 100 | Q - 180 | x-special |
| B - 40 | J - 110 | R - 200 | |
| C - 50 | K - 125 | S - 250 | |
| D - 60 | L - 140 | T - 300 | |
| E - 70 | M - 150 | U - 350 | |
| F - 80 | N - 160 | V - 400 | |
| G - 90 | P - 170 | W - 450 | |

(mm)

4 Sıkma Tipi / Method of Mounting of Insert

C: Deliksiz Üstten Sıkma / Top clamping without hole
 T: Üstten Delikle Sıkma / Top and Hole Clamping
 M: Üstten ve Delikten Sıkma / Top and Hole Clamping
 P: Delikten Laye ile Sıkma / Hole Clamping (Lever Lock)
 S: Vida ile Sıkma / Screw on

5 Uç Tipi / Insert Shape

| | | |
|---|---|---|
| | | |
| C | D | E |
| | | |
| V | R | S |
| | | |
| W | K | T |

6 Yanaşma Açısı / Tool Holder Shape Bar Geometry

7 Serbest Uç Açısı / Insert Clearance Angle

8 Kesme Yönü / Cutting Direction

9 Kesme Kenar Uzunluğu / Cutting Edge Length

10 Baskı Pabucu / Wedge Clamp

T&C-SİSTEM

T&C SİSTEM DELİK TORNA KATERLERİ
T&C SYSTEM BORING BARS

*konuşulan
the spoken kalite...
quality...*



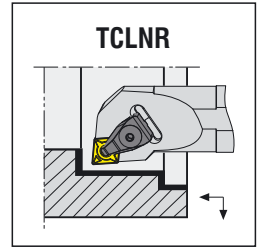
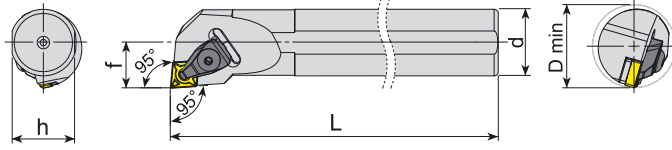

| Takım Kodu Ordering Code | Stok Stock | | Takım Ölçüleri (mm) Dimension (mm) | | | | Kesici Uç Insert | Yedek Parçaları Spare Parts | | | | | | | |
|-----------------------------|---------------|---|---------------------------------------|------|-----|----|---------------------|--------------------------------|-----------------------------|-----------------------------|---------------|----------------------------|---------------|--------------|----------------------|
| | R | L | d | h | L | f | | D min | Baskı Pabucu Wedge Clamp | Pabuç Vidası Clamp Screw | Altık Shim | Altık Vidası Shim Screw | Yay Spring | Pul Stamp | Anahtar Allen Key |
| S25S TCLNR/L 09 | ● | ● | 25 | 23 | 250 | 17 | ≥32 | CNM. 0903.. | ATK-01 | AKV-01-M5x22 | AACN-2-0001 | AAV-09-M5x9 | - | | |
| S25S TCLNR/L 12 | ● | ● | 25 | 23 | 250 | 17 | ≥32 | | | | | | | | |
| S32T TCLNR/L 12 | ● | ● | 32 | 30 | 300 | 22 | ≥40 | CNM. 1204.. | ATK-02 | AKV-02-M6x22 | AACN-3-0001 | AAV-02-M5x12 | AKY-01 | ABPL-01 | AAL-03-3 |
| S40U TCLNR/L 12 | ● | ● | 40 | 37.5 | 350 | 27 | ≥50 | | | | | | | | |
| S50V TCLNR/L 12 | ● | ● | 50 | 47 | 400 | 35 | ≥63 | | | | | | | | |
| S32T TCLNR/L 16 | ● | ● | 32 | 30 | 300 | 22 | ≥40 | | | | | | | | |
| S40U TCLNR/L 16 | ● | ● | 40 | 37.5 | 350 | 27 | ≥50 | CNM. 1606.. | ATK-04 | AKV-19-M7x25 | AACN-3-0002 | AAV-05-M6x15 | - | ABPL-02 | AAL-05-4 |
| S50V TCLNR/L 16 | ● | ● | 50 | 47 | 400 | 35 | ≥63 | | | | | | | | |

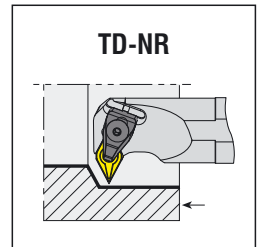
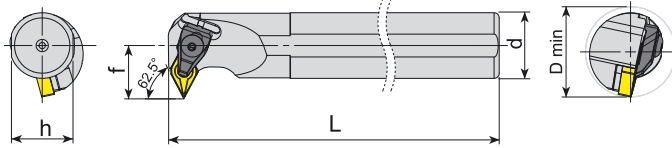

| Takım Kodu Ordering Code | Stok Stock | | Takım Ölçüleri (mm) Dimension (mm) | | | | Kesici Uç Insert | Yedek Parçaları Spare Parts | | | | | | | |
|-----------------------------|---------------|---|---------------------------------------|------|-----|----|---------------------|--------------------------------|-----------------------------|-----------------------------|---------------|----------------------------|---------------|--------------|----------------------|
| | R | L | d | h | L | f | | D min | Baskı Pabucu Wedge Clamp | Pabuç Vidası Clamp Screw | Altık Shim | Altık Vidası Shim Screw | Yay Spring | Pul Stamp | Anahtar Allen Key |
| S32T TD-NR/L 15 | ● | ● | 32 | 30 | 300 | 26 | ≥44 | | | | | | | | |
| S40U TD-NR/L 15 | ● | ● | 40 | 37.5 | 350 | 29 | ≥52 | DNM. 1506.. | ATK-02 | AKV-02-M6x22 | AADN-3-0001 | AAV-02-M5x12 | AKY-01 | ABPL-01 | AAL-03-3 |
| S50V TD-NR/L 15 | ● | ● | 50 | 47 | 400 | 35 | ≥67 | | | | | | | | |

R: Sağ/Right L: Sol/Left ● Stokta/In Stock ○ Stokta Yok/Non Stock Item

Sipariş Örneği/Ordering Example : 1 ad./pcs. S25S TCLNR 09

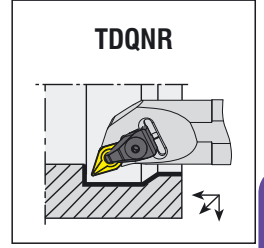
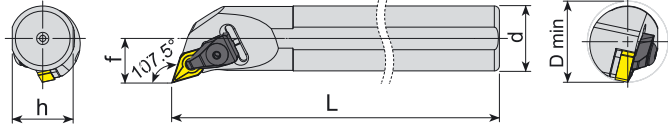

| Takım Kodu Ordering Code | Stok Stock | | Takım Ölçüleri (mm) Dimension (mm) | | | | | Kesici Uç Insert | Yedek Parçaları Spare Parts | | | | | | |
|-----------------------------|-----------------|---|---------------------------------------|------|-----|-----|-------|---------------------|--------------------------------|-----------------------------|---------------|----------------------------|---------------|--------------|----------------------|
| | R | L | d | h | L | f | D min | | Baskı Pabucu Wedge Clamp | Pabuç Vidası Clamp Screw | Altık Shim | Altık Vidası Shim Screw | Yay Spring | Pul Stamp | Anahtar Allen Key |
| | S25S TDQNR/L 11 | ● | ● | 25 | 23 | 250 | 17 | | ≥32 | DNM. 1104.. | ATK-01 | AKV-01-M5x22 | AADN-2-0001 | AAV-09-M5x9 | - |
| S32T TDQNR/L 11 | ● | ● | 32 | 30 | 300 | 22 | ≥40 | AAV-04-M5x12 | | | | | | | |
| S32T TDQNR/L 15 | ● | ● | 32 | 30 | 300 | 22 | ≥40 | DNM. 1506.. | ATK-02 | AKV-02-M6x22 | AADN-3-0001 | AAV-02-M5x12 | AKY-01 | | |
| S40U TDQNR/L 15 | ● | ● | 40 | 37.5 | 350 | 27 | ≥50 | | | | | | | | |
| S50V TDQNR/L 15 | ● | ● | 50 | 47 | 400 | 35 | ≥63 | | | | | | | | |

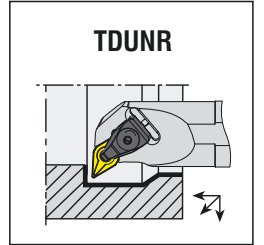
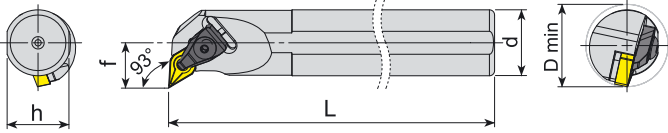

| Takım Kodu Ordering Code | Stok Stock | | Takım Ölçüleri (mm) Dimension (mm) | | | | | Kesici Uç Insert | Yedek Parçaları Spare Parts | | | | | | |
|-----------------------------|-----------------|---|---------------------------------------|------|-----|-----|-------|---------------------|--------------------------------|-----------------------------|---------------|----------------------------|---------------|--------------|----------------------|
| | R | L | d | h | L | f | D min | | Baskı Pabucu Wedge Clamp | Pabuç Vidası Clamp Screw | Altık Shim | Altık Vidası Shim Screw | Yay Spring | Pul Stamp | Anahtar Allen Key |
| | S25S TDUNR/L 11 | ● | ● | 25 | 23 | 250 | 17 | | ≥32 | DNM. 1104.. | ATK-01 | AKV-01-M5x22 | AADN-2-0001 | AAV-09-M5x9 | - |
| S32T TDUNR/L 11 | ● | ● | 32 | 30 | 300 | 22 | ≥40 | AAV-04-M5x12 | | | | | | | |
| S25S TDUNR/L 15 | ● | ● | 25 | 23 | 250 | 17 | ≥32 | DNM. 1506.. | ATK-02 | AKV-02-M6x22 | AADN-3-0001 | AAV-02-M5x12 | AKY-01 | | |
| S32T TDUNR/L 15 | ● | ● | 32 | 30 | 300 | 22 | ≥40 | | | | | | | | |
| S40U TDUNR/L 15 | ● | ● | 40 | 37.5 | 350 | 27 | ≥50 | | | | | | | | |
| S50V TDUNR/L 15 | ● | ● | 50 | 47 | 400 | 35 | ≥63 | | | | | | | | |

R: Sağ/Right L: Sol/Left ● Stokta/In Stock ○ Stokta Yok/Non Stock Item

Sipariş Örneği/Ordering Example : 1 ad./pcs. S25S TDQNR 11

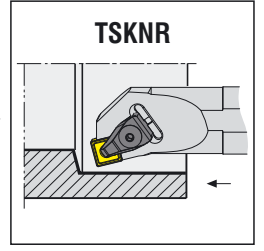
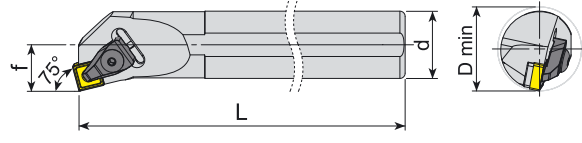
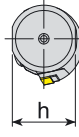

| Takım Kodu Ordering Code | Stok Stock | | Takım Ölçüleri (mm) Dimension (mm) | | | | Kesici Uç Insert | Yedek Parçaları Spare Parts | | | | | | | |
|-----------------------------|---------------|---|---------------------------------------|------|-----|----|---------------------|--------------------------------|-----------------------------|-----------------------------|-----------------|------------------------------|---------------|--------------|----------------------|
| | R | L | d | h | L | f | | D min | Baskı Pabucu Wedge Clamp | Pabuç Vidası Clamp Screw | Altılık Shim | Altılık Vidası Shim Screw | Yay Spring | Pul Stamp | Anahtar Allen Key |
| S25S TSKNR/L 12 | ● | ● | 25 | 23 | 250 | 17 | ≥32 | SNM. 1204.. | ATK-02 | AKV-02-M6x22 | AASN-3-0004 | AAV-02-M5x12 | AKY-01 | ABPL-01 | AAL-03-3 |
| S32T TSKNR/L 12 | ● | ● | 32 | 30 | 300 | 22 | ≥40 | | | | | | | | |
| S40U TSKNR/L 12 | ● | ● | 40 | 37.5 | 350 | 27 | ≥50 | | | | | | | | |

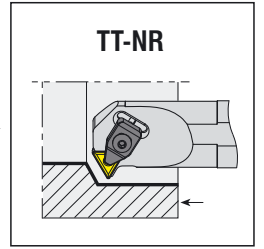
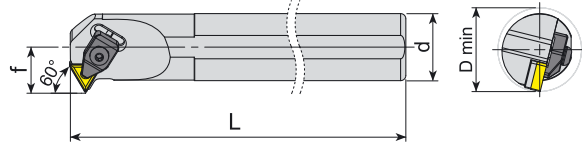
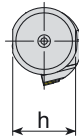

| Takım Kodu Ordering Code | Stok Stock | | Takım Ölçüleri (mm) Dimension (mm) | | | | Kesici Uç Insert | Yedek Parçaları Spare Parts | | | | | | | |
|-----------------------------|---------------|---|---------------------------------------|----|-----|----|---------------------|--------------------------------|-----------------------------|-----------------------------|-----------------|------------------------------|---------------|--------------|----------------------|
| | R | L | d | h | L | f | | D min | Baskı Pabucu Wedge Clamp | Pabuç Vidası Clamp Screw | Altılık Shim | Altılık Vidası Shim Screw | Yay Spring | Pul Stamp | Anahtar Allen Key |
| S25S TT-NR/L 16 | ● | ● | 25 | 23 | 250 | 17 | ≥32 | TNM. 1604.. | ATK-01 | AKV-01-M5x22 | AATN-2-0002 | AAV-03-M5x12 | - | ABPL-01 | AAL-03-3 |
| S32T TT-NR/L 16 | ● | ● | 32 | 30 | 300 | 22 | ≥40 | | | | | | | | |

R: Sağ/Right L: Sol/Left ● Stokta/In Stock ○ Stokta Yok/Non Stock Item

Sipariş Örneği/Ordering Example : 1 ad./pcs. S25S TSKNR 12

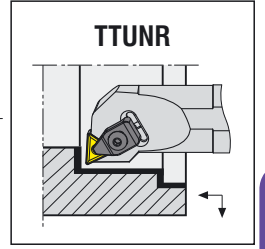
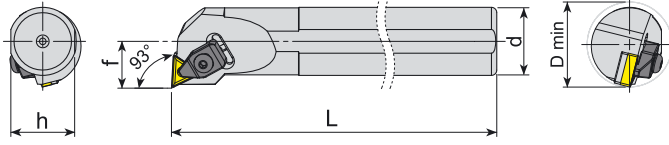

| Takım Kodu Ordering Code | Stok Stock | | Takım Ölçüleri (mm) Dimension (mm) | | | | | Kesici Uç Insert | Yedek Parçaları Spare Parts | | | | | | |
|-----------------------------|-----------------|---|---------------------------------------|------|-----|-----|-------|---------------------|--------------------------------|-----------------------------|---------------|----------------------------|---------------|--------------|----------------------|
| | R | L | d | h | L | f | D min | | Baskı Pabucu Wedge Clamp | Pabuç Vidası Clamp Screw | Altık Shim | Altık Vidası Shim Screw | Yay Spring | Pul Stamp | Anahtar Allen Key |
| | S25S TTUNR/L 16 | ● | ● | 25 | 23 | 250 | 17 | | ≥32 | TNM. 1604.. | ATK-01 | AKV-01-M5x22 | AATN-2-0002 | AAV-03-M5x12 | - |
| S32T TTUNR/L 16 | ● | ● | 32 | 30 | 300 | 22 | ≥40 | | | | | | | | |
| S25S TTUNR/L 22 | ● | ● | 25 | 23 | 250 | 17 | ≥32 | TNM. 2204.. | ATK-02 | AKV-02-M6x22 | AATN-3-0015 | AAV-02-M5x12 | AKY-01 | ABPL-01 | AAL-03-3 |
| S32T TTUNR/L 22 | ● | ● | 32 | 30 | 300 | 22 | ≥40 | | | | | | | | |
| S40U TTUNR/L 22 | ● | ● | 40 | 37.5 | 350 | 27 | ≥50 | | | | | | | | |
| S50V TTUNR/L 22 | ● | ● | 50 | 47 | 400 | 35 | ≥63 | | | | | | | | |

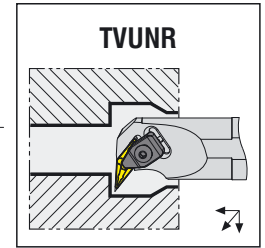
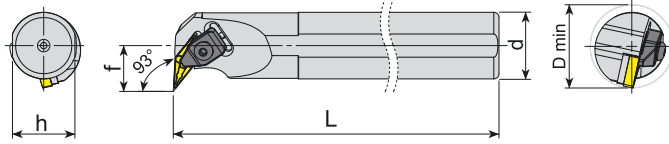

| Takım Kodu Ordering Code | Stok Stock | | Takım Ölçüleri (mm) Dimension (mm) | | | | | Kesici Uç Insert | Yedek Parçaları Spare Parts | | | | | | |
|-----------------------------|-----------------|---|---------------------------------------|------|-----|-----|-------|---------------------|--------------------------------|-----------------------------|---------------|----------------------------|---------------|--------------|----------------------|
| | R | L | d | h | L | f | D min | | Baskı Pabucu Wedge Clamp | Pabuç Vidası Clamp Screw | Altık Shim | Altık Vidası Shim Screw | Yay Spring | Pul Stamp | Anahtar Allen Key |
| | S25S TVUNR/L 16 | ● | ● | 25 | 23 | 250 | 17 | | ≥32 | VNM. 1604.. | ATK-01 | AKV-01-M5x22 | AAVN-2-0002 | AAV-04-M5x12 | - |
| S32T TVUNR/L 16 | ● | ● | 32 | 30 | 300 | 22 | ≥40 | | | | | | | | |
| S40U TVUNR/L 16 | ● | ● | 40 | 37.5 | 350 | 27 | ≥50 | | | | | | | | |

R: Sağ/Right L: Sol/Left ● Stokta/In Stock ○ Stokta Yok/Non Stock Item

Sipariş Örneği/Ordering Example : 1 ad./pcs. S25S TTUNR 16

T-SİSTEM DELİK TORNA KATERLERİ T-SYSTEM BORING BARS

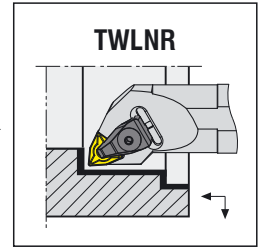
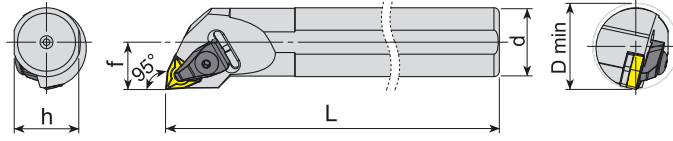

| Takım Kodu Ordering Code | Stok Stock | | Takım Ölçüleri (mm) Dimension (mm) | | | | Kesici Uç Insert | Yedek Parçaları Spare Parts | | | | | | | |
|-----------------------------|------------|---|---------------------------------------|------|-----|----|---------------------|--------------------------------|-----------------------------|-----------------------------|-----------------|------------------------------|---------------|--------------|----------------------|
| | R | L | d | h | L | f | | D min | Baskı Pabucu Wedge Clamp | Pabuç Vidası Clamp Screw | Altılık Shim | Altılık Vidası Shim Screw | Yay Spring | Pul Stamp | Anahtar Allen Key |
| S25S TWLNR/L 06 | ● | ● | 25 | 23 | 250 | 17 | ≥32 | WNM. 0604.. | ATK-01 | AKV-01-M5x22 | AAWN-SW317 | AAV-01-M3x10 | - | ABPL-01 | AAL-03-3 |
| S32T TWLNR/L 06 | ● | ● | 32 | 30 | 300 | 22 | ≥40 | | | | | | | | |
| S25S TWLNR/L 08 | ● | ● | 25 | 23 | 250 | 17 | ≥32 | WNM. 0804.. | ATK-02 | AKV-02-M6x22 | AAWN-3-0001 | AAV-02-M5x12 | AKY-01 | ABPL-01 | AAL-03-3 |
| S32T TWLNR/L 08 | ● | ● | 32 | 30 | 300 | 22 | ≥40 | | | | | | | | |
| S40U TWLNR/L 08 | ● | ● | 40 | 37.5 | 350 | 27 | ≥50 | | | | | | | | |
| S50V TWLNR/L 08 | ● | ● | 50 | 47 | 400 | 35 | ≥63 | | | | | | | | |

C-SİSTEM DELİK TORNA KATERLERİ C-SYSTEM BORING BARS

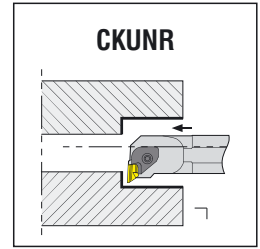
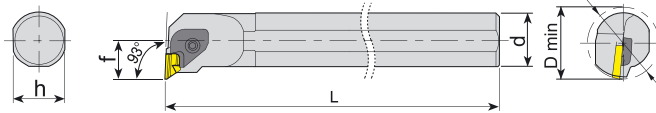

| Takım Kodu Ordering Code | Stok Stock | | Takım Ölçüleri (mm) Dimension (mm) | | | | Kesici Uç Insert | Yedek Parçaları Spare Parts | | | | | | | |
|-----------------------------|------------|---|---------------------------------------|------|-----|----|---------------------|--------------------------------|-----------------------------|-----------------------------|----------------------|------------------------------|---------------|--------------|----------------------|
| | R | L | d | h | L | f | | D min | Baskı Pabucu Wedge Clamp | Pabuç Vidası Clamp Screw | Altılık Shim | Altılık Vidası Shim Screw | Yay Spring | Pul Stamp | Anahtar Allen Key |
| S25S CKUNR/L 16 | ● | ● | 25 | 23 | 250 | 19 | ≥38 | KNUX 1604.. | ACK-01-R ACK-02-L | AKV-06-M6x20 | AKS-16-R AKS-16-L | AAV-01-M3x10 | AKY-02 | ABPL-01 | AAL-05-4 |
| S32T CKUNR/L 16 | ● | ● | 32 | 30 | 300 | 22 | ≥40 | | | | | | | | |
| S40U CKUNR/L 16 | ● | ● | 40 | 37.5 | 350 | 27 | ≥50 | | | | | | | | |
| S50V CKUNR/L 16 | ● | ● | 50 | 47 | 400 | 35 | ≥63 | | | | | | | | |

R: Sağ/Right L: Sol/Left ● Stokta/In Stock ○ Stokta Yok/Non Stock Item

Sipariş Örneği/Ordering Example : 1 ad./pcs. S25S TWLNR 06

M-SİSTEM

M-SİSTEM DELİK TORNA KATERLERİ
M-SYSTEM BORING BARS

*konusulan
the spoken kalite...
quality...*



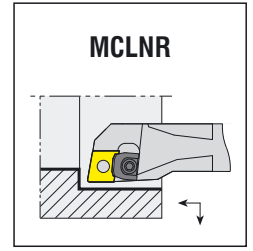
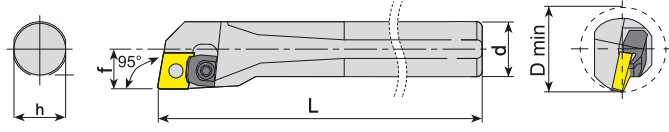

| Takım Kodu Ordering Code | Stok Stock | | Takım Ölçüleri (mm) Dimension (mm) | | | | | Kesici Uç Insert | Yedek Parçaları Spare Parts | | | | | |
|-----------------------------|---------------|---|---------------------------------------|------|-----|----|-------|---------------------|--------------------------------|-----------------------------|----------------|------------|--------------|----------------------|
| | R | L | d | h | L | f | D min | | Baskı Pabucu Wedge Clamp | Pabuç Vidası Clamp Screw | Altlık Shim | Pim Pin | Pul Stamp | Anahtar Allen Key |
| | | | | | | | | | | | | | | |
| S20R MCLNR/L 12 | ●● | | 20 | 18.3 | 200 | 13 | ≥25 | CNM. 1204.. | AMK-03 | AKV-04-M5x17 | - | APM-12 | - | AAL-03-3 |
| S25S MCLNR/L 12 | ●● | | 25 | 23 | 250 | 17 | ≥32 | | | | AACN-3-0001 | APM-13 | | |
| S32T MCLNR/L 12 | ●● | | 32 | 30 | 300 | 22 | ≥40 | | | | | APM-04 | | |

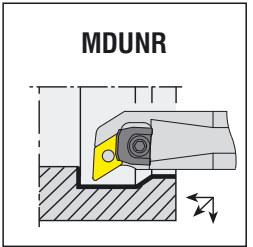
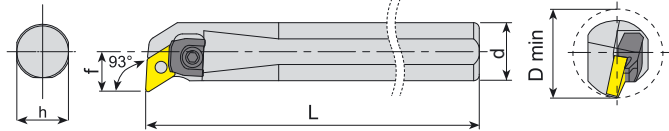

| Takım Kodu Ordering Code | Stok Stock | | Takım Ölçüleri (mm) Dimension (mm) | | | | | Kesici Uç Insert | Yedek Parçaları Spare Parts | | | | | |
|-----------------------------|---------------|---|---------------------------------------|------|-----|----|-------|---------------------|--------------------------------|-----------------------------|----------------|------------|--------------|----------------------|
| | R | L | d | h | L | f | D min | | Baskı Pabucu Wedge Clamp | Pabuç Vidası Clamp Screw | Altlık Shim | Pim Pin | Pul Stamp | Anahtar Allen Key |
| | | | | | | | | | | | | | | |
| S20R MDUNR/L 11 | ●● | | 20 | 18.3 | 200 | 13 | ≥25 | DNM. 1104.. | AMK-03 | AKV-17-M5x15 | - | APM-03 | - | AAL-03-3 |
| S25S MDUNR/L 11 | ●● | | 25 | 23 | 250 | 17 | ≥32 | | | AKV-04-M5x17 | | | | |
| S32T MDUNR/L 11 | ○ | | 32 | 30 | 300 | 22 | ≥40 | | | | | | | |
| S25S MDUNR/L 15 | ●● | | 25 | 23 | 250 | 17 | ≥32 | DNM. 1506.. | AMK-04 | AKV-20-M6x19 | AADN-3-0001 | APM-04 | ABPL-01 | AAL-03-3 |
| S32T MDUNR/L 15 | ●● | | 32 | 30 | 300 | 22 | ≥40 | | | | | | | |
| S40U MDUNR/L 15 | ●● | | 40 | 37.5 | 350 | 27 | ≥50 | | | | | | | |
| S50V MDUNR/L 15 | ●● | | 50 | 47 | 400 | 35 | ≥63 | | | | | | | |

R: Sağ/Right L: Sol/Left ● Stokta/In Stock ○ Stokta Yok/Non Stock Item

Sipariş Örneği/Ordering Example : 1 ad./pcs. S20R MCLNR 12

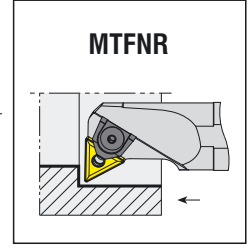
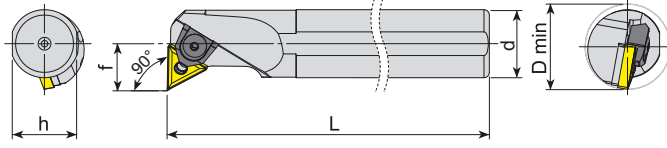

| Takım Kodu Ordering Code | Stok Stock | | Takım Ölçüleri (mm) Dimension (mm) | | | | | Kesici Uç Insert | Yedek Parçaları Spare Parts | | | | | | | |
|-----------------------------|---------------|---|---------------------------------------|------|-----|----|-------|---------------------|--------------------------------|-----------------------------|----------------|------------|--------------|----------------------|----------|--------|
| | R | L | d | h | L | f | D min | | Baskı Pabucu Wedge Clamp | Pabuç Vidası Clamp Screw | Altlık Shim | Pim Pin | Pul Stamp | Anahtar Allen Key | | |
| S20R MTFNR/L 16 | ● | ● | 20 | 18.3 | 200 | 13 | ≥25 | TNM. 1604.. | AMK-02 | AKV-17-M5x15 | - | APM-03 | - | ABPL-01 | AAL-03-3 | |
| S25S MTFNR/L 16 | ● | ● | 25 | 23 | 250 | 17 | ≥32 | | AMK-04 | AKV-02-M6x22 | AATN-2-0002 | APM-14 | | | | |
| S32T MTFNR/L 16 | ● | ● | 32 | 30 | 300 | 22 | ≥40 | | | | | | | | | APM-01 |
| S40U MTFNR/L 16 | ● | ○ | 40 | 37.5 | 350 | 27 | ≥50 | | | | | | | | | |
| S32T MTFNR/L 22 | ○ | ○ | 32 | 30 | 300 | 22 | ≥40 | TNM. 2204.. | AMK-04 | AKV-02-M6x22 | AATN-3-0015 | APM-02 | | | | |
| S40U MTFNR/L 22 | ● | ○ | 40 | 37.5 | 350 | 27 | ≥50 | | | | | | | | | |
| S50V MTFNR/L 22 | ○ | ○ | 50 | 47 | 400 | 35 | ≥63 | | | | | | | | | |

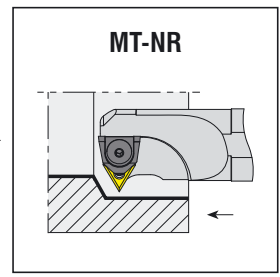
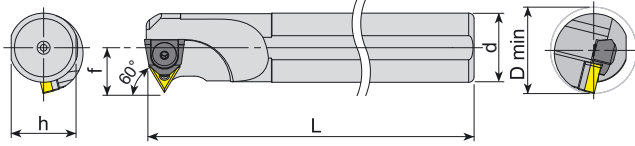

| Takım Kodu Ordering Code | Stok Stock | | Takım Ölçüleri (mm) Dimension (mm) | | | | | Kesici Uç Insert | Yedek Parçaları Spare Parts | | | | | | | | | |
|-----------------------------|---------------|---|---------------------------------------|------|-----|----|-------|---------------------|--------------------------------|-----------------------------|----------------|------------|--------------|----------------------|----------|--|--------|--|
| | R | L | d | h | L | f | D min | | Baskı Pabucu Wedge Clamp | Pabuç Vidası Clamp Screw | Altlık Shim | Pim Pin | Pul Stamp | Anahtar Allen Key | | | | |
| S20R MT-NR/L 16 | ● | ● | 20 | 18.3 | 200 | 13 | ≥25 | TNM. 1604.. | AMK-02 | AKV-04-M5x17 | AATN-2-0002 | APM-03 | - | ABPL-01 | AAL-03-3 | | | |
| S25S MT-NR/L 16 | ● | ● | 25 | 23 | 250 | 17 | ≥32 | | | | | | | | | | APM-14 | |
| S32T MT-NR/L 16 | ● | ● | 32 | 30 | 300 | 22 | ≥40 | | | | | | | | | | APM-01 | |
| S40U MT-NR/L 16 | ● | ● | 40 | 37.5 | 350 | 27 | ≥50 | | | | | | | | | | | |
| S32T MT-NR/L 22 | ● | ● | 32 | 30 | 300 | 22 | ≥40 | TNM. 2204.. | AMK-04 | AKV-02-M6x22 | AATN-3-0015 | APM-02 | | | | | | |
| S40U MT-NR/L 22 | ● | ● | 40 | 37.5 | 350 | 27 | ≥50 | | | | | | | | | | | |
| S50U MT-NR/L 22 | ● | ○ | 50 | 47 | 350 | 35 | ≥63 | | | | | | | | | | | |

R: Sağ/Right L: Sol/Left ● Stokta/In Stock ○ Stokta Yok/Non Stock Item

Sipariş Örneği/Ordering Example : 1 ad./pcs. S20R MTFNR 16

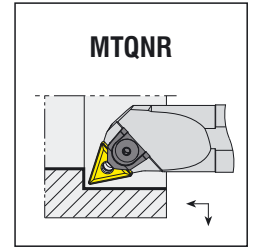
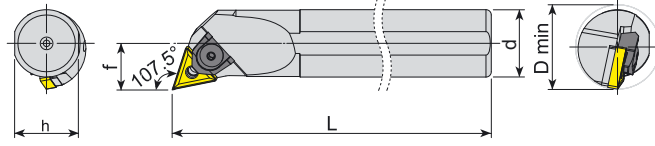

| Takım Kodu Ordering Code | Stok Stock | | Takım Ölçüleri (mm) Dimension (mm) | | | | Kesici Uç Insert | Yedek Parçaları Spare Parts | | | | | | | |
|-----------------------------|---------------|---|---------------------------------------|------|-----|----|---------------------|--------------------------------|-----------------------------|-----------------------------|----------------|------------|--------------|----------------------|----------|
| | R | L | d | h | L | f | | D min | Baskı Pabucu Wedge Clamp | Pabuç Vidası Clamp Screw | Altlık Shim | Pim Pin | Pul Stamp | Anahtar Allen Key | |
| S20R MTQNR/L 16 | ● | ● | 20 | 18.3 | 200 | 13 | ≥25 | TNM. 1604.. | AMK-02 | AKV-17-M5x15 | - | APM-11 | - | ABPL-01 | AAL-03-3 |
| S25S MTQNR/L 16 | ● | ● | 25 | 23 | 250 | 17 | ≥32 | | | | AATN-2-0002 | APM-14 | | | |
| S32T MTQNR/L 16 | ● | ● | 32 | 30 | 300 | 22 | ≥40 | | | | | APM-01 | | | |
| S40U MTQNR/L 16 | ● | ● | 40 | 37.5 | 350 | 27 | ≥50 | | AMK-04 | AKV-02-M6x22 | | | | | |
| S32T MTQNR/L 22 | ● | ● | 32 | 30 | 300 | 22 | ≥40 | TNM. 2204.. | | | AATN-3-0015 | APM-02 | | | |
| S40U MTQNR/L 22 | ● | ● | 40 | 37.5 | 350 | 27 | ≥50 | | | | | | | | |
| S50V MTQNR/L 22 | ● | ● | 50 | 47 | 400 | 35 | ≥63 | | | | | | | | |

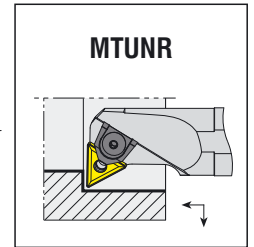
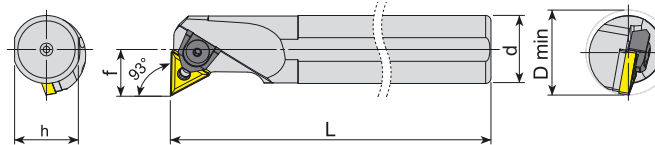

| Takım Kodu Ordering Code | Stok Stock | | Takım Ölçüleri (mm) Dimension (mm) | | | | Kesici Uç Insert | Yedek Parçaları Spare Parts | | | | | | | |
|-----------------------------|---------------|---|---------------------------------------|------|-----|----|---------------------|--------------------------------|-----------------------------|-----------------------------|----------------|------------|--------------|----------------------|----------|
| | R | L | d | h | L | f | | D min | Baskı Pabucu Wedge Clamp | Pabuç Vidası Clamp Screw | Altlık Shim | Pim Pin | Pul Stamp | Anahtar Allen Key | |
| S20R MTUNR/L 16 | ● | ● | 20 | 18.3 | 200 | 13 | ≥25 | TNM. 1604.. | AMK-02 | AKV-17-M5x15 | - | APM-03 | - | ABPL-01 | AAL-03-3 |
| S25S MTUNR/L 16 | ● | ● | 25 | 23 | 250 | 17 | ≥32 | | | | AATN-2-0002 | APM-14 | | | |
| S32T MTUNR/L 16 | ● | ● | 32 | 30 | 300 | 22 | ≥40 | | | | | APM-01 | | | |
| S40U MTUNR/L 16 | ● | ● | 40 | 37.5 | 350 | 27 | ≥50 | | AMK-04 | AKV-02-M6x22 | | | | | |
| S32T MTUNR/L 22 | ● | ● | 32 | 30 | 300 | 22 | ≥40 | TNM. 2204.. | | | AATN-3-0015 | APM-02 | | | |
| S40U MTUNR/L 22 | ● | ● | 40 | 37.5 | 350 | 27 | ≥50 | | | | | | | | |
| S50V MTUNR/L 22 | ● | ● | 50 | 47 | 400 | 35 | ≥63 | | | | | | | | |

R: Sağ/Right L: Sol/Left ● Stokta/In Stock ○ Stokta Yok/Non Stock Item

Sipariş Örneği/Ordering Example : 1 ad./pcs. S20R MTQNR 16

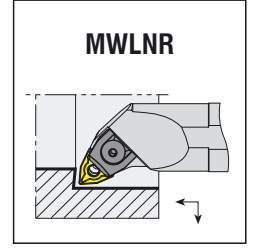
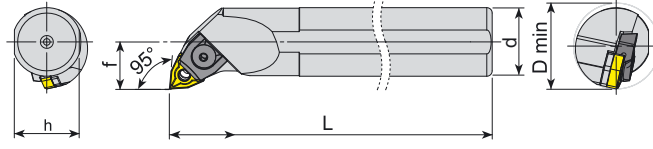

| Takım Kodu Ordering Code | Stok Stock | | Takım Ölçüleri (mm) Dimension (mm) | | | | | Kesici Uç Insert | Yedek Parçaları Spare Parts | | | | | | |
|-----------------------------|---------------|---|---------------------------------------|------|-----|----|-------|---------------------|--------------------------------|-----------------------------|----------------|--------------|--------------|----------------------|--------|
| | R | L | d | h | L | f | D min | | Baskı Pabucu Wedge Clamp | Pabuç Vidası Clamp Screw | Altlık Shim | Pim Pin | Pul Stamp | Anahtar Allen Key | |
| S16P MWLNR/L 06 | ● | ● | 16 | 14.8 | 170 | 11 | ≥21 | WNM. 0604.. | | | - | APM-09 | - | AAL-03-3 | |
| S20R MWLNR/L 06 | ● | ● | 20 | 18.3 | 200 | 13 | ≥25 | | | | | AKV-04-M5x17 | | | APM-10 |
| S25S MWLNR/L 06 | ● | ● | 25 | 23 | 250 | 17 | ≥32 | | | | | AKV-20-M6x19 | | | APM-08 |
| S25S MWLNR/L 08 | ● | ● | 25 | 23 | 250 | 17 | ≥32 | WNM. 0804.. | | | AAWN-3-0001 | APM-02 | ABPL-01 | | |
| S32T MWLNR/L 08 | ● | ● | 32 | 30 | 300 | 22 | ≥40 | | | | | | | | |
| S40U MWLNR/L 08 | ● | ● | 40 | 37.5 | 350 | 27 | ≥50 | | | | | | | | |

R: Sağ/Right L: Sol/Left ● Stokta/In Stock ○ Stokta Yok/Non Stock Item

Sipariş Örneği/Ordering Example : 1 ad./pcs. S16P MWLNR 06





*konusulan
the spoken kalite...
quality...*

P-SİSTEM

P-SİSTEM DELİK TORNA KATERLERİ
P-SYSTEM BORING BARS



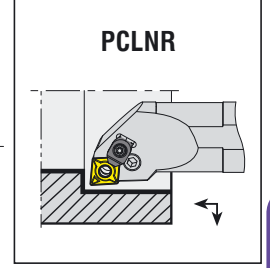
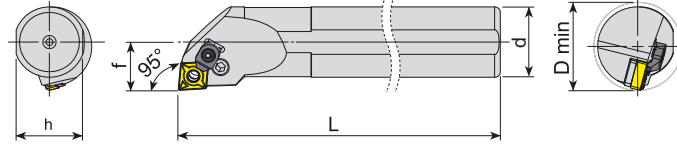

| Takım Kodu Ordering Code | Stok Stock | | Takım Ölçüleri (mm) Dimension (mm) | | | | | Kesici Uç Insert | Yedek Parçaları Spare Parts | | | | | | |
|-----------------------------|---------------|---|---------------------------------------|------|-----|----|-------|---------------------|--------------------------------|-----------------------------|---------------|---------------------------|------------------------------|-----------------------------|----------------------|
| | R | L | d | h | L | f | D min | | Levye Lever | Levye Vidası Lever Screw | Altık Shim | Altık Yayı Shim Spring | Baskı Parçası Wedge Clamp | Baskı Vidası Clamp Screw | Anahtar Allen Key |
| | ● | ○ | | | | | | | | | | | | | |
| S16P PCLNR/L 09 | ● | ● | 16 | 14.8 | 170 | 11 | ≥21 | CNM. 0903.. | APL-07 | ALV-07-M6x13 | - | - | - | - | - |
| S20R PCLNR/L 09 | ● | ● | 20 | 18.3 | 200 | 13 | ≥25 | | APL-01 | ALV-01-M6x14 | AACN-2-0002 | AAY-01 | - | - | AAL-02-2.5 |
| S25S PCLNR/L 09 | ○ | ○ | 25 | 23 | 250 | 17 | ≥32 | | | ALV-08-M8x15 | | | | | |
| S25S PCLNR/L 12C | ● | ● | 25 | 23 | 250 | 17 | ≥32 | CNM. 1204.. | APL-02 | ALV-03-M8x19 | AACN-3-0001 | AAY-02 | ACK-05 | 1515-M4x11 | AAL-03-3 |
| S32T PCLNR/L 12C | ● | ● | 32 | 30 | 300 | 22 | ≥40 | | | | | | | | |
| S40U PCLNR/L 12C | ● | ● | 40 | 37.5 | 350 | 27 | ≥50 | | | | | | | | |
| S50V PCLNR/L 12C | ● | ● | 50 | 47 | 400 | 35 | ≥63 | CNM. 1606.. | APL-04 | ALV-04-M8x22 | AACN-3-0002 | AAY-03 | ACK-09 | AAV-05-M6x15 | AAL-05-4 |
| S32T PCLNR/L 16C | ● | ● | 32 | 30 | 300 | 22 | ≥40 | | | | | | | | |
| S40U PCLNR/L 16C | ● | ● | 40 | 37.5 | 350 | 27 | ≥50 | | | | | | | | |
| S50V PCLNR/L 16C | ● | ● | 50 | 47 | 400 | 35 | ≥63 | CNM. 1906.. | APL-05 | ALV-05-M10x27 | AACN-3-0003 | AAY-04 | ACK-09 | AAV-05-M6x15 | AAL-05-4 |
| S40U PCLNR/L 19C | ● | ● | 40 | 37.5 | 350 | 27 | ≥50 | | | | | | | | |
| S50V PCLNR/L 19C | ● | ● | 50 | 47 | 400 | 35 | ≥63 | | | | | | | | |
| A25R PCLNR/L 12C | ● | ● | 25 | 23 | 200 | 17 | ≥32 | CNM. 1204.. | APL-02 | ALV-03-M8x19 | AACN-3-0001 | AAY-02 | ACK-05 | 1515-M4x11 | AAL-03-3 |
| A32S PCLNR/L 12C | ● | ● | 32 | 30 | 250 | 22 | ≥40 | | | | | | | | |
| A40T PCLNR/L 12C | ● | ● | 40 | 37.5 | 300 | 27 | ≥50 | | | | | | | | |
| A50U PCLNR/L 12C | ● | ● | 50 | 47 | 350 | 35 | ≥63 | CNM. 1606.. | APL-04 | ALV-04-M8x22 | AACN-3-0002 | AAY-03 | ACK-09 | AAV-05-M6x15 | AAL-05-4 |
| A32S PCLNR/L 16C | ● | ● | 32 | 30 | 250 | 22 | ≥40 | | | | | | | | |
| A40T PCLNR/L 16C | ● | ● | 40 | 37.5 | 300 | 27 | ≥50 | | | | | | | | |
| A50U PCLNR/L 16C | ● | ● | 50 | 47 | 350 | 35 | ≥63 | CNM. 1906.. | APL-05 | ALV-05-M10x27 | AACN-3-0003 | AAY-04 | ACK-09 | AAV-05-M6x15 | AAL-05-4 |
| A40T PCLNR/L 19C | ● | ○ | 40 | 37.5 | 300 | 27 | ≥50 | | | | | | | | |
| A50U PCLNR/L 19C | ● | ● | 50 | 47 | 350 | 35 | ≥63 | | | | | | | | |

R: Sağ/Right L: Sol/Left ● Stokta/In Stock ○ Stokta Yok/Non Stock Item

Sipariş Örneği/Ordering Example : 1 ad./pcs. S16P PCLNR 09

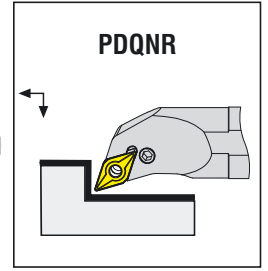
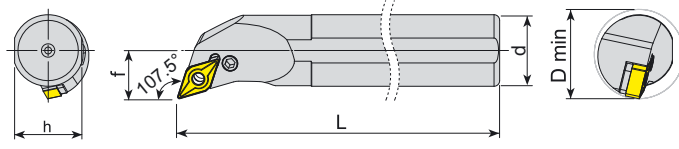

| Takım Kodu Ordering Code | Stok Stock | | Takım Ölçüleri (mm) Dimension (mm) | | | | | Kesici Uç Insert | Yedek Parçaları Spare Parts | | | | | | |
|-----------------------------|---------------|---|---------------------------------------|------|-----|----|-------|---------------------|--------------------------------|-------------------------------|-----------------|-----------------------------|------------------------------|-----------------------------|----------------------|
| | R | L | d | h | L | f | D min | | Levyeye Lever | Levyeye Vidası Lever Screw | Altılık Shim | Altılık Yayı Shim Spring | Baskı Parçası Wedge Clamp | Baskı Vidası Clamp Screw | Anahtar Allen Key |
| | ○ | ● | | | | | | | | | | | | | |
| S20R PDQNR/L 11 | ○ | ○ | 20 | 18.3 | 200 | 13 | ≥25 | DNM. 1104.. | APL-01 | ALV-01-M6x14 ALV-02-M6x17 | AADN-SD317 | AAY-01 | | | AAL-02-2.5 |
| S25S PDQNR/L 11 | ● | ● | 25 | 23 | 250 | 17 | ≥32 | | | | | | | | |
| S32T PDQNR/L 15 | ● | ● | 32 | 30 | 300 | 22 | ≥40 | DNM. 1506.. | APL-03 | ALV-03-M8x19 | AADN-3-0001 | AAY-02 | - | - | AAL-03-3 |
| S40U PDQNR/L 15 | ● | ● | 40 | 37.5 | 350 | 27 | ≥50 | | | | | | | | |
| S50V PDQNR/L 15 | ● | ● | 50 | 47 | 400 | 35 | ≥63 | DNM. 1504.. | APL-03 | ALV-03-M8x19 | AADN-2-0003 | AAY-02 | - | - | AAL-03-3 |
| S32T PDQNR/L 1504 | ● | ● | 32 | 30 | 300 | 22 | ≥40 | | | | | | | | |
| S40U PDQNR/L 1504 | ● | ● | 40 | 37.5 | 350 | 27 | ≥50 | DNM. 1506.. | APL-03 | ALV-03-M8x19 | AADN-3-0001 | AAY-02 | - | - | AAL-03-3 |
| S50V PDQNR/L 1504 | ● | ● | 50 | 47 | 400 | 35 | ≥63 | | | | | | | | |
| A20P PDQNR/L 11 | ● | ● | 20 | 18.3 | 170 | 13 | ≥25 | DNM. 1104.. | APL-01 | ALV-01-M6x14 ALV-02-M6x17 | AADN-SD317 | AAY-01 | - | - | AAL-02-2.5 |
| A25R PDQNR/L 11 | ● | ● | 25 | 23 | 200 | 17 | ≥32 | | | | | | | | |
| A32S PDQNR/L 15 | ● | ● | 32 | 30 | 250 | 22 | ≥40 | DNM. 1506.. | APL-03 | ALV-03-M8x19 | AADN-3-0001 | AAY-02 | - | - | AAL-03-3 |
| A40T PDQNR/L 15 | ● | ● | 40 | 37.5 | 300 | 27 | ≥50 | | | | | | | | |
| A50U PDQNR/L 15 | ● | ● | 50 | 47 | 350 | 35 | ≥63 | DNM. 1504.. | APL-03 | ALV-03-M8x19 | AADN-2-0003 | AAY-02 | - | - | AAL-03-3 |
| A32S PDQNR/L 1504 | ● | ○ | 32 | 30 | 250 | 22 | ≥40 | | | | | | | | |
| A40T PDQNR/L 1504 | ● | ○ | 40 | 37.5 | 300 | 27 | ≥50 | | | | | | | | |

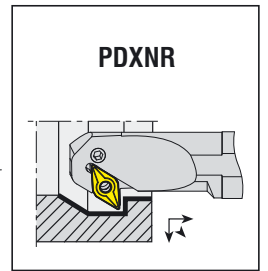
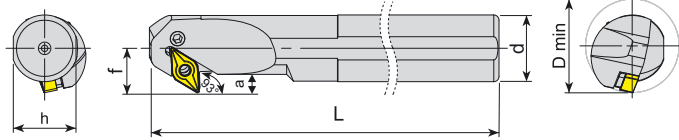

| Takım Kodu Ordering Code | Stok Stock | | Takım Ölçüleri (mm) Dimension (mm) | | | | | Kesici Uç Insert | Yedek Parçaları Spare Parts | | | | | | | |
|-----------------------------|---------------|---|---------------------------------------|------|-----|----|----|---------------------|--------------------------------|------------------|-------------------------------|-----------------|-----------------------------|------------------------------|-----------------------------|----------------------|
| | R | L | d | h | L | f | a | | D min | Levyeye Lever | Levyeye Vidası Lever Screw | Altılık Shim | Altılık Yayı Shim Spring | Baskı Parçası Wedge Clamp | Baskı Vidası Clamp Screw | Anahtar Allen Key |
| | ○ | ● | | | | | | | | | | | | | | |
| S32T PDXNR/L 15 | ● | ● | 32 | 30 | 300 | 25 | 12 | ≥45 | DNM. 150608 | APL-03 | ALV-08-M8x15 ALV-03-M8x19 | AADN-3-0001 | AAY-02 | - | - | AAL-03-3 |
| S40U PDXNR/L 15 | ● | ● | 40 | 37.5 | 350 | 27 | 14 | ≥50 | | | | | | | | |
| S50V PDXNR/L 15 | ● | ● | 50 | 47 | 400 | 35 | 19 | ≥63 | | | | | | | | |

R: Sağ/Right L: Sol/Left ● Stokta/In Stock ○ Stokta Yok/Non Stock Item

Sipariş Örneği/Ordering Example : 1 ad./pcs. S20R PDQNR 11

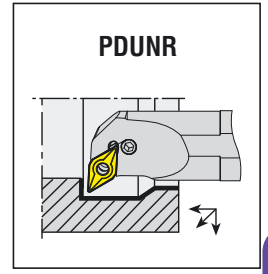
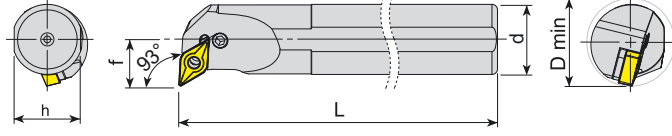

| Takım Kodu Ordering Code | Stok Stock | | Takım Ölçüleri (mm) Dimension (mm) | | | | | Kesici Uç Insert | Yedek Parçaları Spare Parts | | | | | | |
|-----------------------------|---------------|---|---------------------------------------|------|-----|----|-------|---------------------|--------------------------------|------------------------------|----------------|----------------------------|------------------------------|-----------------------------|----------------------|
| | R | L | d | h | L | f | D min | | Levye Lever | Levye Vidası Lever Screw | Altlık Shim | Altlık Yayı Shim Spring | Baskı Parçası Wedge Clamp | Baskı Vidası Clamp Screw | Anahtar Allen Key |
| | ● | ○ | | | | | | | | | | | | | |
| S20R PDUNR/L 11 | ● | ● | 20 | 18.3 | 200 | 13 | ≥25 | DNM. 1104.. | APL-01 | ALV-01-M6x14 ALV-02-M6x17 | AADN-SD317 | AAY-01 | - | - | AAL-02-2.5 |
| S25S PDUNR/L 11 | ● | ● | 25 | 23 | 250 | 17 | ≥32 | | | | | | | | |
| S25S PDUNR/L 15 | ● | ● | 25 | 23 | 250 | 17 | ≥32 | DNM. 1506.. | APL-03 | ALV-03-M8x19 | AADN-3-0001 | AAY-02 | - | - | AAL-03-3 |
| S32T PDUNR/L 15 | ● | ● | 32 | 30 | 300 | 22 | ≥40 | | | | | | | | |
| S40U PDUNR/L 15 | ● | ● | 40 | 37.5 | 350 | 27 | ≥50 | DNM. 1104.. | APL-01 | ALV-01-M6x14 ALV-02-M6x17 | AADN-SD317 | AAY-01 | - | - | AAL-2-2.5 |
| S50V PDUNR/L 15 | ● | ● | 50 | 47 | 400 | 35 | ≥63 | | | | | | | | |
| A20P PDUNR/L 11 | ● | ● | 20 | 18.3 | 170 | 13 | ≥25 | DNM. 1104.. | APL-01 | ALV-01-M6x14 ALV-02-M6x17 | AADN-SD317 | AAY-01 | - | - | AAL-2-2.5 |
| A25R PDUNR/L 11 | ● | ● | 25 | 23 | 200 | 17 | ≥32 | | | | | | | | |
| A32S PDUNR/L 15 | ● | ● | 32 | 30 | 250 | 22 | ≥40 | DNM. 1506.. | APL-03 | ALV-03-M8x19 | AADN-3-0001 | AAY-02 | - | - | AAL-03-3 |
| A40T PDUNR/L 15 | ● | ● | 40 | 37.5 | 300 | 27 | ≥50 | | | | | | | | |
| A50U PDUNR/L 15 | ● | ● | 50 | 47 | 350 | 35 | ≥63 | | | | | | | | |

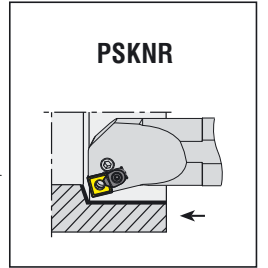
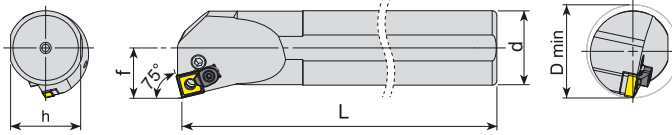

| Takım Kodu Ordering Code | Stok Stock | | Takım Ölçüleri (mm) Dimension (mm) | | | | | Kesici Uç Insert | Yedek Parçaları Spare Parts | | | | | | |
|-----------------------------|---------------|---|---------------------------------------|------|-----|----|-------|---------------------|--------------------------------|------------------------------|----------------|----------------------------|------------------------------|-----------------------------|----------------------|
| | R | L | d | h | L | f | D min | | Levye Lever | Levye Vidası Lever Screw | Altlık Shim | Altlık Yayı Shim Spring | Baskı Parçası Wedge Clamp | Baskı Vidası Clamp Screw | Anahtar Allen Key |
| | ● | ○ | | | | | | | | | | | | | |
| S25S PSKNR/L 12C | ● | ● | 25 | 23 | 250 | 17 | ≥32 | SNM. 1204.. | APL-02 | ALV-08-M8x15 ALV-03-M8x19 | AASN-3-0004 | AAY-02 | ACK-05 | 1515-M4x11 | AAL-03-3 |
| S32T PSKNR/L 12C | ● | ● | 32 | 30 | 300 | 22 | ≥40 | | | | | | | | |
| S40U PSKNR/L 12C | ● | ● | 40 | 37.5 | 350 | 27 | ≥50 | | | | | | | | |
| S50V PSKNR/L 12C | ● | ● | 50 | 47 | 400 | 35 | ≥63 | | | | | | | | |
| S32T PSKNR/L 15 | ○ | ○ | 32 | 30 | 300 | 22 | ≥40 | SNM. 1506.. | APL-04 | ALV-04-M8x22 | AASN-3-0023 | AAY-03 | - | - | AAL-05-4 |
| S40U PSKNR/L 15 | ○ | ○ | 40 | 37.5 | 350 | 27 | ≥50 | | | | | | | | |
| S50V PSKNR/L 15 | ○ | ○ | 50 | 47 | 400 | 35 | ≥63 | | | | | | | | |

R: Sağ/Right L: Sol/Left ● Stokta/In Stock ○ Stokta Yok/Non Stock Item

Sipariş Örneği/Ordering Example : 1 ad./pcs. S25S PSKNR 12C

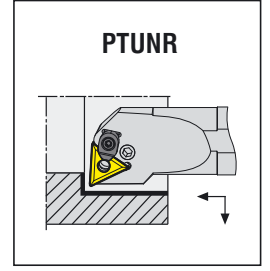
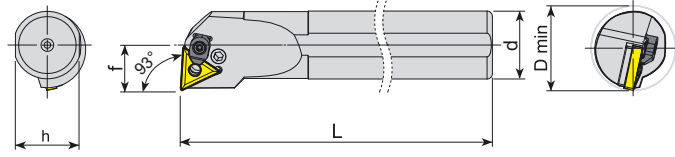

| Takım Kodu Ordering Code | Stok Stock | | Takım Ölçüleri (mm) Dimension (mm) | | | | Kesici Uç Insert | Yedek Parçaları Spare Parts | | | | | | | |
|-----------------------------|---------------|---|---------------------------------------|------|-----|----|---------------------|--------------------------------|----------------|-----------------------------|---------------|---------------------------|------------------------------|-----------------------------|----------------------|
| | R | L | d | h | L | f | | D min | Levye Lever | Levye Vidası Lever Screw | Altık Shim | Altık Yayı Shim Spring | Baskı Parçası Wedge Clamp | Baskı Vidası Clamp Screw | Anahtar Allen Key |
| S16P PTUNR/L 16 | ● | ● | 16 | 14.8 | 170 | 11 | ≥21 | TNM. 1604.. | APL-07 | ALV-07-M6x13 | | | | | |
| S20R PTUNR/L 16 | ● | ● | 20 | 18.3 | 200 | 13 | ≥25 | | | ALV-01-M6x14 | | | | | |
| S25S PTUNR/L 16C | ● | ● | 25 | 23 | 250 | 17 | ≥32 | | APL-01 | ALV-02-M6x17 | AATN-3-0025 | AAY-01 | | | AAL-02-2.5 |
| S32T PTUNR/L 16C | ● | ● | 32 | 30 | 300 | 22 | ≥40 | | | | | | | | |
| S40U PTUNR/L 16C | ● | ● | 40 | 37.5 | 350 | 27 | ≥50 | | | | | | | | |
| S32T PTUNR/L 22C | ● | ● | 32 | 30 | 300 | 22 | ≥40 | TNM. 2204.. | APL-02 | ALV-03-M8x19 | AATN-3-0015 | AAY-02 | ACK-05 | 1515-M4x11 | AAL-03-3 |
| S40U PTUNR/L 22C | ● | ● | 40 | 37.5 | 350 | 27 | ≥50 | | | | | | | | |
| S50V PTUNR/L 22C | ● | ● | 50 | 47 | 400 | 35 | ≥63 | | | | | | | | |



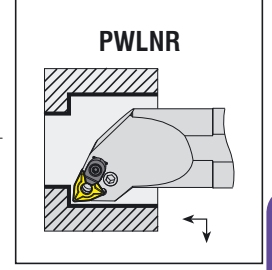
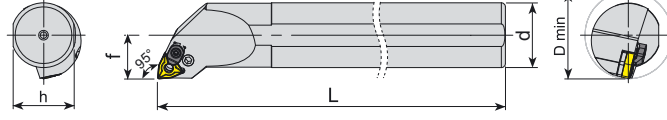

| Takım Kodu Ordering Code | Stok Stock | | Takım Ölçüleri (mm) Dimension (mm) | | | | | Kesici Uç Insert | Yedek Parçaları Spare Parts | | | | | | |
|-----------------------------|---------------|---|---------------------------------------|------|-----|----|-------|---------------------|--------------------------------|-----------------------------|---------------|---------------------------|------------------------------|-----------------------------|----------------------|
| | R | L | d | h | L | f | D min | | Levye Lever | Levye Vidası Lever Screw | Altık Shim | Altık Yayı Shim Spring | Baskı Parçası Wedge Clamp | Baskı Vidası Clamp Screw | Anahtar Allen Key |
| | ● | ○ | ● | ○ | ● | ○ | ● | | ● | ● | ● | ● | ● | ● | ● |
| S20R PWLNR/L 06 | ● | ● | 20 | 18.3 | 200 | 13 | ≥25 | WNM. 0604.. | APL-01 | ALV-01-M6x14 | AAWN-SW317 | AAY-01 | - | - | AAL-02-2.5 |
| S25S PWLNR/L 06 | ● | ● | 25 | 23 | 250 | 17 | ≥32 | | | ALV-02-M6x17 | | | | | |
| S32T PWLNR/L 06 | ● | ● | 32 | 30 | 300 | 22 | ≥40 | | | | | | | | |
| S25S PWLNR/L 08C | ● | ● | 25 | 23 | 250 | 17 | ≥32 | WNM. 0804.. | APL-02 | ALV-03-M8x19 | AAWN-3-0001 | AAY-02 | ACK-05 | 1515-M4x11 | AAL-03-3 |
| S32T PWLNR/L 08C | ● | ● | 32 | 30 | 300 | 22 | ≥40 | | | | | | | | |
| S40U PWLNR/L 08C | ● | ● | 40 | 37.5 | 350 | 27 | ≥50 | | | | | | | | |
| S50V PWLNR/L 08C | ● | ● | 50 | 47 | 400 | 35 | ≥63 | WNM. 0604.. | APL-01 | ALV-01-M6x14 | AAWN-SW317 | AAY-01 | - | - | AAL-02-2.5 |
| A20P PWLNR/L 06 | ● | ● | 20 | 18.3 | 170 | 13 | ≥25 | | | ALV-02-M6x17 | | | | | |
| A25R PWLNR/L 06 | ● | ● | 25 | 23 | 200 | 17 | ≥32 | | | | | | | | |
| A32S PWLNR/L 06 | ● | ● | 32 | 30 | 250 | 22 | ≥40 | WNM. 0804.. | APL-02 | ALV-03-M8x19 | AAWN-3-0001 | AAY-02 | ACK-05 | 1515-M4x11 | AAL-03-3 |
| A25R PWLNR/L 08C | ● | ● | 25 | 23 | 200 | 17 | ≥32 | | | | | | | | |
| A32S PWLNR/L 08C | ● | ● | 32 | 30 | 250 | 22 | ≥40 | | | | | | | | |
| A40T PWLNR/L 08C | ● | ● | 40 | 37.5 | 300 | 27 | ≥50 | | | | | | | | |
| A50U PWLNR/L 08C | ● | ● | 50 | 47 | 350 | 22 | ≥63 | | | | | | | | |

R: Sağ/Right L: Sol/Left ● Stokta/In Stock ○ Stokta Yok/Non Stock Item

Sipariş Örneği/Ordering Example : 1 ad./pcs. S20R PWLNR 06





*konusulan
the spoken kalite...
quality...*

S-SİSTEM

S-SİSTEM DELİK TORNA KATERLERİ
S-SYSTEM BORING BARS



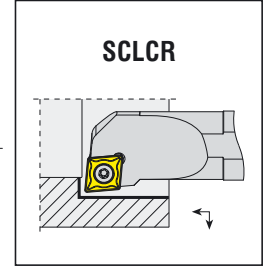
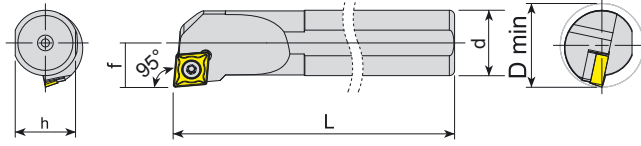

| Takım Kodu Ordering Code | Stok Stock | | Takım Ölçüleri (mm) Dimension (mm) | | | | Kesici Uç Insert | Yedek Parçaları Spare Parts | | | | |
|-----------------------------|---------------|---|---------------------------------------|------|-----|-----|---------------------|--------------------------------|-----------------------|---------------|----------------------------|--------------------------|
| | R | L | d | h | L | f | | D min | Sıkma Vidası Screw | Altık Shim | Altık Vidası Shim Screw | Tork Anahtar Torx Key |
| S0608H SCLCR/L 06 | ● | ● | 06 | 7.3 | 100 | 4.5 | ≥8 | CC.T 0602.. | 4008-M2.5x4.5 | | | 80-T08 |
| S08H SCLCR/L 06 | ● | ● | 08 | 7.3 | 100 | 06 | ≥11 | | 4008-M2.5x6 | - | - | |
| S10K SCLCR/L 06 | ● | ● | 10 | 09 | 125 | 07 | ≥13 | | | | | |
| S12K SCLCR/L 06 | ● | ● | 12 | 11 | 125 | 09 | ≥16 | | | | | |
| S16P SCLCR/L 06 | ● | ● | 16 | 14.8 | 170 | 11 | ≥21 | | | | | |
| S12K SCLCR/L 09 | ● | ● | 12 | 11 | 125 | 09 | ≥16 | CC.T 09T3.. | 4015-M3.5x8 | | | 80-T15 |
| S16P SCLCR/L 09 | ● | ● | 16 | 14.8 | 170 | 11 | ≥21 | | 4015-M3.5x9 | - | - | |
| S20R SCLCR/L 09 | ● | ● | 20 | 18.3 | 200 | 13 | ≥25 | | | | | |
| S25S SCLCR/L 09 | ● | ● | 25 | 23 | 250 | 17 | ≥32 | 4015-M3.5x12 | AACN-2-0001 | AAV-08-M3.5x8 | | |
| S32T SCLCR/L 09 | ● | ● | 32 | 30 | 300 | 22 | ≥40 | CC.T 1204.. | 4020-M4.5x12 | AACN-2-0003 | AAV-10-M4.5x8 | 80-T20 |
| S25S SCLCR/L 12 | ● | ● | 25 | 23 | 250 | 17 | ≥32 | | 1020-M4.5x16 | | AAV-07-M4.5x13 | |
| S32T SCLCR/L 12 | ● | ● | 32 | 30 | 300 | 22 | ≥40 | | | | | |
| S40U SCLCR/L 12 | ● | ● | 40 | 37.5 | 350 | 27 | ≥50 | | | | | |
| A08H SCLCR/L 06 | ● | ● | 08 | 7.3 | 100 | 06 | ≥11 | CC.T 0602.. | 4008-M2.5x6 | - | - | 80-T08 |
| A10H SCLCR/L 06 | ● | ● | 10 | 09 | 100 | 07 | ≥13 | | | | | |
| A12H SCLCR/L 06 | ● | ● | 12 | 11 | 100 | 09 | ≥16 | | | | | |
| A16M SCLCR/L 09 | ● | ● | 16 | 14.8 | 150 | 11 | ≥21 | CC.T 09T3.. | 4015-M3.5x9 | - | - | 80-T15 |
| A20P SCLCR/L 09 | ● | ● | 20 | 18.3 | 170 | 13 | ≥25 | | | | | |
| A25R SCLCR/L 09 | ● | ● | 25 | 23 | 200 | 17 | ≥32 | | | | | |
| A32S SCLCR/L 09 | ● | ● | 32 | 30 | 250 | 22 | ≥40 | | 4015-M3.5x12 | AACN-2-0001 | AAV-08-M3.5x8 | |
| A25R SCLCR/L 12 | ● | ● | 25 | 23 | 200 | 17 | ≥32 | | 4020-M4.5x12 | AACN-2-0003 | AAV-10-M4.5x8 | |

R: Sağ/Right L: Sol/Left ● Stokta/In Stock ○ Stokta Yok/Non Stock Item

Sipariş Örneği/Ordering Example : 1 ad./pcs. S0608H SCLCR 06

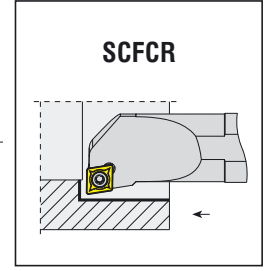
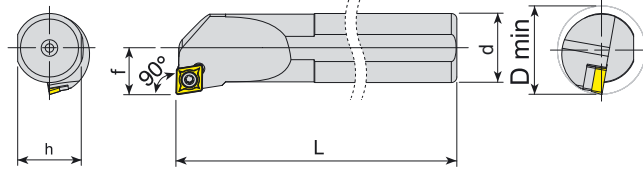

| Takım Kodu Ordering Code | Stok Stock | | Takım Ölçüleri (mm) Dimension (mm) | | | | | Kesici Uç Insert | Yedek Parçaları Spare Parts | | | |
|-----------------------------|---------------|---|---------------------------------------|------|-----|----|-------|---------------------|--------------------------------|----------------|-----------------------------|--------------------------|
| | R | L | d | h | L | f | D min | | Sıkma Vidası Screw | Altlık Shim | Altlık Vidası Shim Screw | Tork Anahtar Torx Key |
| | | | | | | | | | | | | |
| S08H SCFCR/L 06 | ● | ● | 08 | 7.3 | 100 | 06 | ≥11 | CC.T 0602.. | 4008-M2.5x6 | - | - | 80-T08 |
| S10K SCFCR/L 06 | ● | ● | 10 | 09 | 125 | 07 | ≥13 | | | | | |
| S12K SCFCR/L 06 | ● | ● | 12 | 11 | 125 | 09 | ≥16 | | | | | |
| S12K SCFCR/L 09 | ● | ● | 12 | 11 | 125 | 09 | ≥16 | CC.T 09T3.. | 4015-M3.5x8 | - | - | 80-T15 |
| S16P SCFCR/L 09 | ● | ● | 16 | 14.8 | 170 | 11 | ≥21 | | | | | |
| S20R SCFCR/L 09 | ● | ● | 20 | 18.3 | 200 | 13 | ≥25 | | | | | |
| S25S SCFCR/L 09 | ● | ● | 25 | 23 | 250 | 17 | ≥32 | CC.T 1204.. | 4015-M3.5x12 | AACN-2-0001 | AAV-08-M3.5x8 | 80-T20 |
| S25S SCFCR/L 12 | ○ | ○ | 25 | 23 | 250 | 17 | ≥32 | | | | | |
| S32T SCFCR/L 12 | ○ | ○ | 32 | 30 | 300 | 22 | ≥40 | | | | | |
| S40U SCFCR/L 12 | ○ | ○ | 40 | 37.5 | 350 | 27 | ≥50 | | 4020-M4.5x12 | AACN-2-0003 | AAV-10-M4.5x8 | |
| | | | | | | | | | 1020-M4.5x16 | | AAV-07-M4.5x13 | |

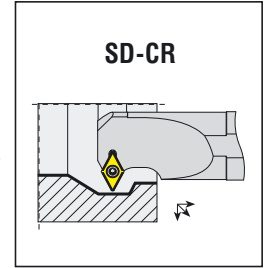
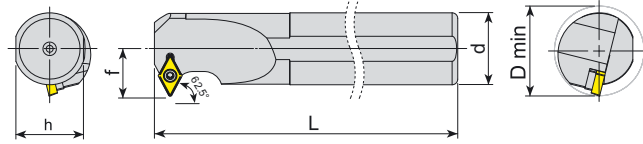

| Takım Kodu Ordering Code | Stok Stock | | Takım Ölçüleri (mm) Dimension (mm) | | | | | Kesici Uç Insert | Yedek Parçaları Spare Parts | | | |
|-----------------------------|---------------|---|---------------------------------------|------|-----|----|-------|---------------------|--------------------------------|----------------|-----------------------------|--------------------------|
| | R | L | d | h | L | f | D min | | Sıkma Vidası Screw | Altlık Shim | Altlık Vidası Shim Screw | Tork Anahtar Torx Key |
| | | | | | | | | | | | | |
| S12K SD-CR/L 07 | ● | ● | 12 | 11 | 125 | 09 | ≥17 | DC.T 0702.. | 4008-M2.5x6 | - | - | 80-T08 |
| S16P SD-CR/L 07 | ○ | ○ | 16 | 14.8 | 170 | 11 | ≥21 | | | | | |
| S20R SD-CR/L 07 | ○ | ○ | 20 | 18.3 | 200 | 13 | ≥25 | | | | | |
| S16P SD-CR/L 11 | ● | ● | 16 | 14.8 | 170 | 11 | ≥21 | DC.T 11T3.. | 4015-M3.5x11 | - | - | 80-T15 |
| S20R SD-CR/L 11 | ● | ● | 20 | 18.3 | 200 | 13 | ≥25 | | | | | |
| S25S SD-CR/L 11 | ● | ● | 25 | 23 | 250 | 17 | ≥32 | | | | | |
| S32T SD-CR/L 11 | ● | ● | 32 | 30 | 300 | 22 | ≥40 | | 4015-M3.5x14 | AADN-2-0001 | AAV-08-M3.5x8 | 80-T15 |
| S40U SD-CR/L 11 | ● | ● | 40 | 37.5 | 350 | 27 | ≥50 | | | | | |

R: Sağ/Right L: Sol/Left ● Stokta/In Stock ○ Stokta Yok/Non Stock Item

Sipariş Örneği/Ordering Example : 1 ad./pcs. S12K SD-CR 07

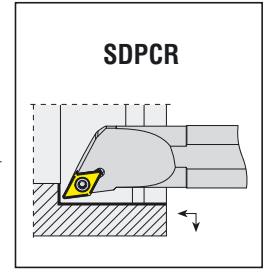
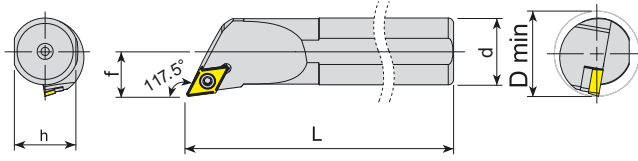

| Takım Kodu Ordering Code | Stok Stock | | Takım Ölçüleri (mm) Dimension (mm) | | | | | Kesici Uç Insert | Yedek Parçaları Spare Parts | | | |
|-----------------------------|---------------|---|---------------------------------------|------|-----|----|-------|---------------------|--------------------------------|---------------|----------------------------|--------------------------|
| | R | L | d | h | L | f | D min | | Sıkma Vidası Screw | Altık Shim | Altık Vidası Shim Screw | Tork Anahtar Torx Key |
| S10K SDPCR/L 07 | ● | ● | 10 | 09 | 125 | 07 | ≥13 | DC.T 0702.. | 4008-M2.5x6 | - | - | 80-T08 |
| S12K SDPCR/L 07 | ● | ● | 12 | 11 | 125 | 09 | ≥16 | | | | | |
| S16P SDPCR/L 11 | ● | ● | 16 | 14.8 | 170 | 11 | ≥21 | DC.T 11T3.. | 4015-M3.5x11 | - | - | 80-T15 |
| S20R SDPCR/L 11 | ● | ● | 20 | 18.3 | 200 | 13 | ≥25 | | | | | |
| S25S SDPCR/L 11 | ● | ● | 25 | 23 | 250 | 17 | ≥32 | | | | | |

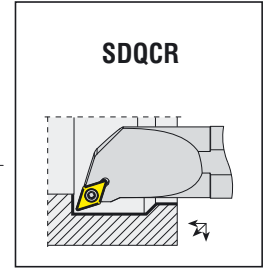
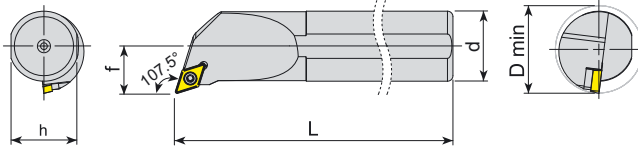

| Takım Kodu Ordering Code | Stok Stock | | Takım Ölçüleri (mm) Dimension (mm) | | | | | Kesici Uç Insert | Yedek Parçaları Spare Parts | | | |
|-----------------------------|---------------|---|---------------------------------------|------|-----|----|-------|---------------------|---|---------------------------------|----------------------------|--------------------------|
| | R | L | d | h | L | f | D min | | Sıkma Vidası Screw | Altık Shim | Altık Vidası Shim Screw | Tork Anahtar Torx Key |
| S10K SDQCR/L 07 | ● | ● | 10 | 09 | 125 | 07 | ≥13 | DC.T 0702.. | 4008-M2.5x6 | - | - | 80-T08 |
| S12K SDQCR/L 07 | ● | ● | 12 | 11 | 125 | 09 | ≥16 | | | | | |
| S16P SDQCR/L 07 | ● | ● | 16 | 14.8 | 170 | 11 | ≥21 | | | | | |
| S20R SDQCR/L 07 | ● | ● | 20 | 18.3 | 200 | 13 | ≥25 | DC.T 11T3.. | 4015-M3.5x9 4015-M3.5x11 4015-M3.5x12 | - | - | 80-T15 |
| S16P SDQCR/L 11 | ● | ● | 16 | 14.8 | 170 | 11 | ≥21 | | | | | |
| S20R SDQCR/L 11 | ● | ● | 20 | 18.3 | 200 | 13 | ≥25 | | | | | |
| S25S SDQCR/L 11 | ● | ● | 25 | 23 | 250 | 17 | ≥32 | | | | | |
| S32T SDQCR/L 11 | ● | ● | 32 | 30 | 300 | 22 | ≥40 | 4015-M3.5x14 | - | - | 80-T15 | |
| S40U SDQCR/L 11 | ○ | ○ | 40 | 37.5 | 350 | 27 | ≥50 | | | | | 4015-M3.5x14 |
| A10H SDQCR/L 07 | ● | ● | 10 | 09 | 100 | 07 | ≥13 | DC.T 0702.. | 4008-M2.5x6 | - | - | 80-T08 |
| A12H SDQCR/L 07 | ● | ● | 12 | 11 | 100 | 09 | ≥16 | | | | | |
| A16M SDQCR/L 07 | ● | ● | 16 | 14.8 | 150 | 11 | ≥21 | | | | | |
| A20P SDQCR/L 07 | ● | ● | 20 | 18.3 | 170 | 13 | ≥25 | | | | | |
| A16M SDQCR/L 11 | ● | ● | 16 | 14.8 | 150 | 11 | ≥21 | | | | | |
| A20P SDQCR/L 11 | ● | ● | 20 | 18.3 | 170 | 13 | ≥25 | | | | | |
| A25R SDQCR/L 11 | ● | ● | 25 | 23 | 200 | 17 | ≥32 | | | | | |
| A32S SDQCR/L 11 | ● | ● | 32 | 30 | 250 | 22 | ≥40 | 4015-M3.5x12 | AADN-2-0001 | AAV-08-M3.5x8 AAV-06-M3.5x11 | | |

R: Sağ/Right L: Sol/Left ● Stokta/In Stock ○ Stokta Yok/Non Stock Item

Sipariş Örneği/Ordering Example : 1 ad./pcs. S10K SDQCR 07

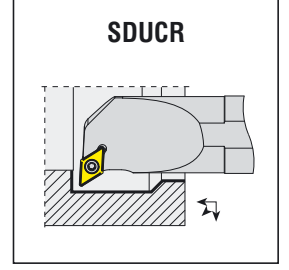
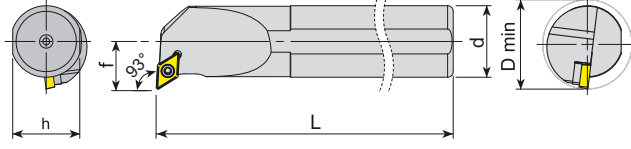

| Takım Kodu Ordering Code | Stok Stock | | Takım Ölçüleri (mm) Dimension (mm) | | | | Kesici Uç Insert | Yedek Parçaları Spare Parts | | | | |
|-----------------------------|---------------|---|---------------------------------------|------|-----|----|---------------------|--------------------------------|-----------------------|---------------------------------|----------------------------|--------------------------|
| | R | L | d | h | L | f | | D min | Sıkma Vidası Screw | Altık Shim | Altık Vidası Shim Screw | Tork Anahtar Torx Key |
| S0810K SDUCR/L 07 | ● | ○ | 08 | 09 | 125 | 06 | ≥11 | DC.T 0702.. | 4008-M2.5x6 | - | - | 80-T08 |
| S10K SDUCR/L 07 | ● | ● | 10 | 09 | 125 | 07 | ≥13 | | | | | |
| S12K SDUCR/L 07 | ● | ● | 12 | 11 | 125 | 09 | ≥16 | | | | | |
| S16P SDUCR/L 07 | ● | ● | 16 | 14.8 | 170 | 11 | ≥21 | | | | | |
| S20R SDUCR/L 07 | ● | ● | 20 | 18.3 | 200 | 13 | ≥25 | DC.T 11T3.. | 4015-M3.5x11 | - | - | 80-T15 |
| S16P SDUCR/L 11 | ● | ● | 16 | 14.8 | 170 | 11 | ≥21 | | | | | |
| S20R SDUCR/L 11 | ● | ● | 20 | 18.3 | 200 | 13 | ≥25 | | | | | |
| S25S SDUCR/L 11 | ● | ● | 25 | 23 | 250 | 17 | ≥32 | | | | | |
| S32T SDUCR/L 11 | ● | ● | 32 | 30 | 300 | 22 | ≥40 | 4015-M3.5x14 | AADN-2-0001 | AAV-06-M3.5x11 | 80-T15 | |
| S40U SDUCR/L 11 | ● | ● | 40 | 37.5 | 350 | 27 | ≥50 | | | | | |
| S50V SDUCR/L 11 | ● | ○ | 50 | 47 | 400 | 35 | ≥63 | | | | | |
| A0810H SDUCR/L 07 | ● | ○ | 08 | 09 | 100 | 06 | ≥11 | DC.T 0702.. | 4008-M2.5x6 | - | - | 80-T08 |
| A10H SDUCR/L 07 | ● | ● | 10 | 09 | 100 | 07 | ≥13 | | | | | |
| A12H SDUCR/L 07 | ● | ● | 12 | 11 | 100 | 09 | ≥16 | | | | | |
| A16M SDUCR/L 07 | ● | ● | 16 | 14.8 | 150 | 11 | ≥21 | | | | | |
| A20P SDUCR/L 07 | ● | ● | 20 | 18.3 | 170 | 13 | ≥25 | DC.T 11T3.. | 4015-M3.5x11 | - | - | 80-T15 |
| A16M SDUCR/L 11 | ● | ● | 16 | 14.8 | 150 | 11 | ≥21 | | | | | |
| A20P SDUCR/L 11 | ● | ● | 20 | 18.3 | 170 | 13 | ≥25 | | | | | |
| A25R SDUCR/L 11 | ● | ● | 25 | 23 | 200 | 17 | ≥32 | | | | | |
| A32S SDUCR/L 11 | ● | ● | 32 | 30 | 250 | 22 | ≥40 | 4015-M3.5x14 | AADN-2-0001 | AAV-08-M3.5x8 AAV-06-M3.5x11 | 80-T15 | |

R: Sağ/Right L: Sol/Left ● Stokta/In Stock ○ Stokta Yok/Non Stock Item

Sipariş Örneği/Ordering Example : 1 ad./pcs. S0810K SDUCR 07



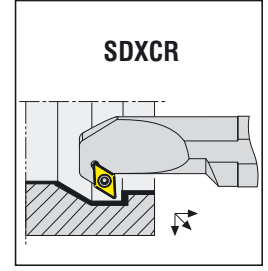
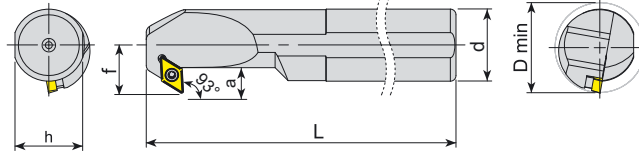

| Takım Kodu Ordering Code | Stok Stock | | Takım Ölçüleri (mm) Dimension (mm) | | | | | Kesici Uç Insert | Yedek Parçaları Spare Parts | | | | |
|-----------------------------|---------------|---|---------------------------------------|------|-----|----|-----|---------------------|--------------------------------|-----------------------|-----------------|------------------------------|--------------------------|
| | R | L | d | h | L | f | a | | D min | Sıkma Vidası Screw | Altılık Shim | Altılık Vidası Shim Screw | Tork Anahtar Torx Key |
| S12K SDXCR/L 07 | ● | ● | 12 | 11 | 125 | 09 | 4 | ≥17 | DC.T 070208 | 4008-M2.5x6 | - | - | 80-T08 |
| S16P SDXCR/L 07 | ● | ● | 16 | 14.8 | 170 | 11 | 6 | ≥21 | | | | | |
| S20R SDXCR/L 07 | ○ | ○ | 20 | 18.3 | 200 | 13 | 6 | ≥25 | | | | | |
| S16P SDXCR/L 11 | ○ | ○ | 16 | 14.8 | 170 | 11 | 6 | ≥21 | DC.T 11T308 | 4015-M3.5x11 | - | - | 80-T15 |
| S20R SDXCR/L 11 | ● | ● | 20 | 18.3 | 200 | 13 | 6 | ≥25 | | | | | |
| S25S SDXCR/L 11 | ● | ● | 25 | 23 | 250 | 17 | 8.5 | ≥32 | | | | | |
| S32T SDXCR/L 11 | ● | ● | 32 | 30 | 300 | 22 | 12 | ≥40 | | | | | |
| S40U SDXCR/L 11 | ● | ● | 40 | 37.5 | 350 | 27 | 14 | ≥50 | 4015-M3.5x14 | AADN-2-0001 | AAV-08-M3.5x8 | AAV-06-M3.5x11 | |

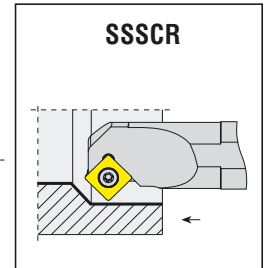
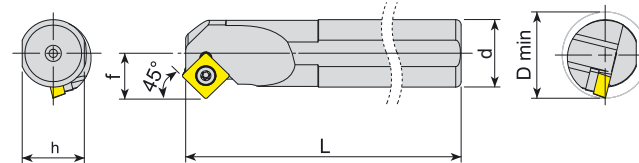

| Takım Kodu Ordering Code | Stok Stock | | Takım Ölçüleri (mm) Dimension (mm) | | | | | Kesici Uç Insert | Yedek Parçaları Spare Parts | | | |
|-----------------------------|---------------|---|---------------------------------------|------|-----|----|-------|---------------------|--------------------------------|-----------------|------------------------------|--------------------------|
| | R | L | d | h | L | f | D min | | Sıkma Vidası Screw | Altılık Shim | Altılık Vidası Shim Screw | Tork Anahtar Torx Key |
| S16P SSSCR/L 09 | ● | ● | 16 | 14.8 | 170 | 11 | ≥21 | SC.T 09T3.. | 4015-M3.5x9 | - | - | 80-T15 |
| S20R SSSCR/L 09 | ● | ● | 20 | 18.3 | 200 | 13 | ≥25 | | | | | |
| S25S SSSCR/L 09 | ● | ● | 25 | 23 | 250 | 17 | ≥32 | | | | | |
| S25S SSSCR/L 12 | ● | ○ | 25 | 23 | 250 | 17 | ≥32 | SC.T 1204.. | 4020-M4.5x12 | AASN-2-0004 | AAV-10-M4.5x8 | 80-T20 |
| S32T SSSCR/L 12 | ○ | ○ | 32 | 30 | 300 | 22 | ≥40 | | | | | |
| S40U SSSCR/L 12 | ○ | ○ | 40 | 37.5 | 350 | 27 | ≥50 | | | | | |
| | | | | | | | | | 1020-M4.5x16 | | AAV-07-M4.5x13 | |

R: Sağ/Right L: Sol/Left ● Stokta/In Stock ○ Stokta Yok/Non Stock Item

Sipariş Örneği/Ordering Example : 1 ad./pcs. S12K SDXCR 07

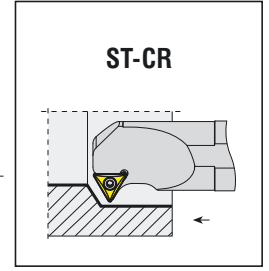
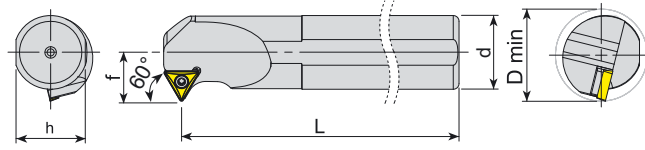

| Takım Kodu Ordering Code | Stok Stock | | Takım Ölçüleri (mm) Dimension (mm) | | | | | Kesici Uç Insert | Yedek Parçaları Spare Parts | | | | | |
|-----------------------------|---------------|---|---------------------------------------|------|-----|----|-------|---------------------|--------------------------------|---------------|----------------------------|--------------------------|-------------|----------------|
| | R | L | d | h | L | f | D min | | Sıkma Vidası Screw | Altık Shim | Altık Vidası Shim Screw | Tork Anahtar Torx Key | | |
| S12K ST-CR/L 11 | ○ | ○ | 12 | 11 | 125 | 09 | ≥17 | TC.T 1102.. | 4008-M2.5x6 | - | - | 80-T08 | | |
| S16P ST-CR/L 11 | ○ | ○ | 16 | 14.8 | 170 | 11 | ≥21 | | | | | | | |
| S20R ST-CR/L 11 | ○ | ○ | 20 | 18.3 | 200 | 13 | ≥25 | | | | | | | |
| S16P ST-CR/L 16 | ● | ● | 16 | 14.8 | 170 | 11 | ≥21 | TC.T 16T3.. | 4015-M3.5x9 | - | - | 80-T15 | | |
| S20R ST-CR/L 16 | ● | ● | 20 | 18.3 | 200 | 13 | ≥25 | | 4015-M3.5x11 | | | | | |
| S25S ST-CR/L 16 | ● | ● | 25 | 23 | 250 | 17 | ≥32 | | 4015-M3.5x14 | | | | AATN-2-0001 | AAV-06-M3.5x11 |
| S32T ST-CR/L 16 | ● | ● | 32 | 30 | 300 | 22 | ≥40 | | | | | | | |
| S40U ST-CR/L 16 | ● | ● | 40 | 37.5 | 350 | 27 | ≥50 | | | | | | | |

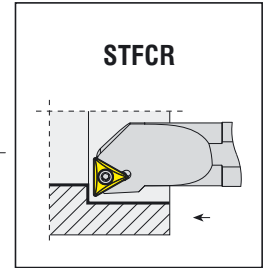
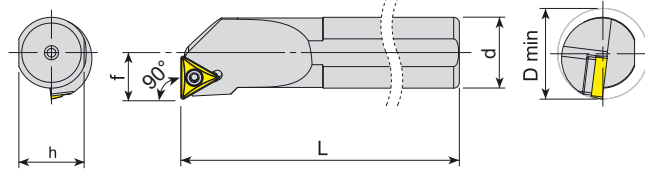

| Takım Kodu Ordering Code | Stok Stock | | Takım Ölçüleri (mm) Dimension (mm) | | | | | Kesici Uç Insert | Yedek Parçaları Spare Parts | | | | | |
|-----------------------------|---------------|---|---------------------------------------|------|-----|----|-------|---------------------|--------------------------------|---------------|----------------------------|--------------------------|-------------|----------------|
| | R | L | d | h | L | f | D min | | Sıkma Vidası Screw | Altık Shim | Altık Vidası Shim Screw | Tork Anahtar Torx Key | | |
| S0610F STFCR/L 06 | ● | ● | 06 | 09 | 80 | 04 | ≥08 | TC.T 06T1.. | 3006-M2x4 | - | - | 80-T06 | | |
| S10K STFCR/L 09 | ● | ● | 10 | 09 | 125 | 07 | ≥13 | TC.T 0902.. | 3007-M2.2x5 | | | 80-T07 | | |
| S12K STFCR/L 09 | ● | ● | 12 | 11 | 125 | 09 | ≥17 | TC.T 1102.. | 4008-M2.5x6 | - | - | 80-T08 | | |
| S12K STFCR/L 11 | ● | ● | 12 | 11 | 125 | 09 | ≥17 | | | | | | | |
| S16P STFCR/L 11 | ● | ● | 16 | 14.8 | 170 | 11 | ≥21 | | | | | | | |
| S16P STFCR/L 16 | ● | ● | 16 | 14.8 | 170 | 11 | ≥21 | TC.T 16T3.. | 4015-M3.5x9 | - | - | 80-T15 | | |
| S20R STFCR/L 11 | ● | ● | 20 | 18.3 | 200 | 13 | ≥25 | | 4015-M3.5x11 | | | | | |
| S20R STFCR/L 16 | ● | ● | 20 | 18.3 | 200 | 13 | ≥25 | | 4015-M3.5x12 | | | | AATN-2-0001 | AAV-08-M3.5x8 |
| S25S STFCR/L 16 | ● | ● | 25 | 23 | 250 | 17 | ≥32 | | 4015-M3.5x14 | | | | | AAV-06-M3.5x11 |
| S32T STFCR/L 16 | ● | ● | 32 | 30 | 300 | 22 | ≥40 | | | | | | | |
| S40U STFCR/L 16 | ○ | ○ | 40 | 37.5 | 350 | 27 | ≥50 | | | | | | | |

R: Sağ/Right L: Sol/Left ● Stokta/In Stock ○ Stokta Yok/Non Stock Item

Sipariş Örneği/Ordering Example : 1 ad./pcs. S12K ST-CR 11

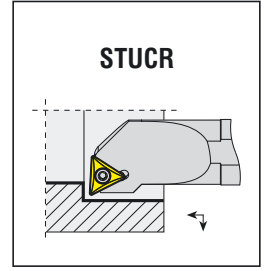
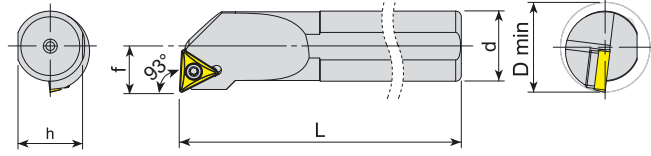

| Takım Kodu Ordering Code | Stok Stock | | Takım Ölçüleri (mm) Dimension (mm) | | | | | Kesici Uç Insert | Yedek Parçaları Spare Parts | | | |
|-----------------------------|---------------|---|---------------------------------------|------|-----|----|-------|---------------------|---|----------------|---------------------------------|--------------------------|
| | R | L | d | h | L | f | D min | | Sıkma Vidası Screw | Altlık Shim | Altlık Vidası Shim Screw | Tork Anahtar Torx Key |
| S10K STUCR/L 09 | ● | ● | 10 | 09 | 125 | 07 | ≥13 | TC.T 0902.. | 3007-M2.2x5 | | | 80-T07 |
| S12K STUCR/L 09 | ● | ● | 12 | 11 | 125 | 09 | ≥17 | | | | | |
| S12K STUCR/L 11 | ● | ● | 12 | 11 | 125 | 09 | ≥17 | TC.T 1102.. | 4008-M2.5x6 | - | - | 80-T08 |
| S16P STUCR/L 11 | ● | ● | 16 | 14.8 | 170 | 11 | ≥21 | | | | | |
| S20R STUCR/L 11 | ● | ● | 20 | 18.3 | 200 | 13 | ≥25 | TC.T 16T3.. | 4015-M3.5x9 4015-M3.5x11 4015-M3.5x12 4015-M3.5x14 | AATN-2-0001 | AAV-08-M3.5x8 AAV-06-M3.5x11 | 80-T15 |
| S16P STUCR/L 16 | ● | ● | 16 | 14.8 | 170 | 11 | ≥21 | | | | | |
| S20R STUCR/L 16 | ● | ● | 20 | 18.3 | 200 | 13 | ≥25 | | | | | |
| S25S STUCR/L 16 | ● | ● | 25 | 23 | 250 | 17 | ≥32 | | | | | |
| S32T STUCR/L 16 | ● | ● | 32 | 30 | 300 | 22 | ≥40 | | | | | |
| S40U STUCR/L 16 | ● | ● | 40 | 37.5 | 350 | 27 | ≥50 | | | | | |

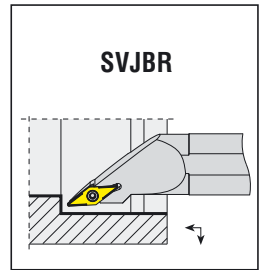
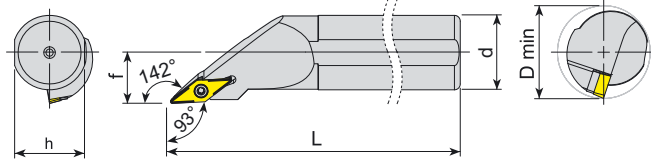

| Takım Kodu Ordering Code | Stok Stock | | Takım Ölçüleri (mm) Dimension (mm) | | | | | Kesici Uç Insert | Yedek Parçaları Spare Parts | | | |
|-----------------------------|---------------|---|---------------------------------------|------|-----|----|-------|---------------------|--------------------------------|----------------|---------------------------------|--------------------------|
| | R | L | d | h | L | f | D min | | Sıkma Vidası Screw | Altlık Shim | Altlık Vidası Shim Screw | Tork Anahtar Torx Key |
| S25S SVJBR/L 16 | ● | ● | 25 | 23 | 250 | 17 | ≥32 | VBM. 1604.. | 4015-M3.5x12 4015-M3.5x14 | AAVN-2-0002 | AAV-08-M3.5x8 AAV-06-M3.5x11 | 80-T15 |
| S32T SVJBR/L 16 | ● | ● | 32 | 30 | 300 | 22 | ≥40 | | | | | |
| S40U SVJBR/L 16 | ● | ● | 40 | 37.5 | 350 | 27 | ≥50 | | | | | |

R: Sağ/Right L: Sol/Left ● Stokta/In Stock ○ Stokta yok/Non Stock: Item

Sipariş Örneği/Ordering Example : 1 ad./pcs. S10K STUCR 09

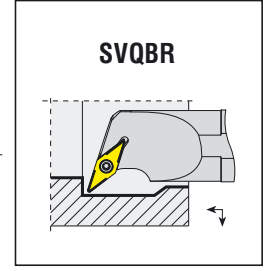
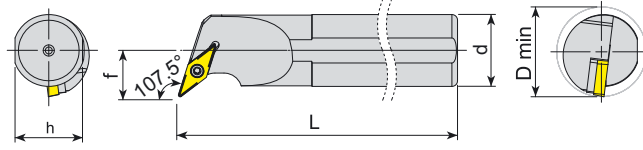

| Takım Kodu Ordering Code | Stok Stock | | Takım Ölçüleri (mm) Dimension (mm) | | | | | Kesici Uç Insert | Yedek Parçaları Spare Parts | | | |
|-----------------------------|---------------|---|---------------------------------------|------|-----|----|-------|---------------------|--------------------------------|---------------|----------------------------|--------------------------|
| | R | L | d | h | L | f | D min | | Sıkma Vidası Screw | Altık Shim | Altık Vidası Shim Screw | Tork Anahtar Torx Key |
| S16P SVQBR/L 11 | ● | ● | 16 | 14.8 | 170 | 11 | ≥21 | VBM. 1103.. | 4008-M2.5x6 | - | - | 80-T08 |
| S20R SVQBR/L 11 | ● | ● | 20 | 18.3 | 200 | 13 | ≥25 | | | | | |
| S25S SVQBR/L 16 | ● | ● | 25 | 23 | 250 | 17 | ≥32 | VBM. 1604.. | 4015-M3.5x14 | AAVN-2-0002 | AAV-06-M3.5x11 | 80-T15 |
| S32T SVQBR/L 16 | ● | ● | 32 | 30 | 300 | 22 | ≥40 | | | | | |
| S40U SVQBR/L 16 | ● | ● | 40 | 37.5 | 350 | 27 | ≥50 | | | | | |

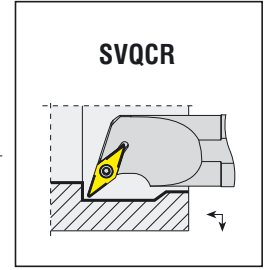
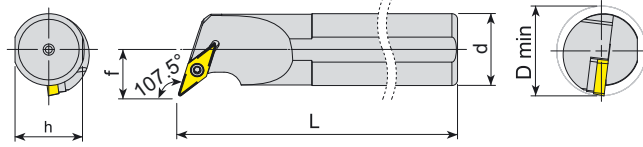

| Takım Kodu Ordering Code | Stok Stock | | Takım Ölçüleri (mm) Dimension (mm) | | | | | Kesici Uç Insert | Yedek Parçaları Spare Parts | | | |
|-----------------------------|---------------|---|---------------------------------------|------|-----|----|-------|---------------------|--------------------------------|---------------|----------------------------|--------------------------|
| | R | L | d | h | L | f | D min | | Sıkma Vidası Screw | Altık Shim | Altık Vidası Shim Screw | Tork Anahtar Torx Key |
| S16P SVQCR/L 11 | ● | ● | 16 | 14.8 | 170 | 11 | ≥21 | VC.T 1103.. | 4008-M2.5x6 | - | - | 80-T08 |
| S20R SVQCR/L 11 | ● | ● | 20 | 18.3 | 200 | 13 | ≥25 | | | | | |
| S25S SVQCR/L 16 | ● | ● | 25 | 23 | 250 | 17 | ≥32 | VC.T 1604.. | 4015-M3.5x14 | AAVN-2-0002 | AAV-06-M3.5x11 | 80-T15 |
| S32T SVQCR/L 16 | ● | ● | 32 | 30 | 300 | 22 | ≥40 | | | | | |
| S40U SVQCR/L 16 | ● | ● | 40 | 37.5 | 350 | 27 | ≥50 | | | | | |

R: Sağ/Right L: Sol/Left ● Stokta/In Stock ○ Stokta Yok/Non Stock Item

Sipariş Örneği/Ordering Example : 1 ad./pcs. S16P SVQBR 11

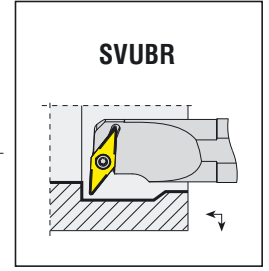
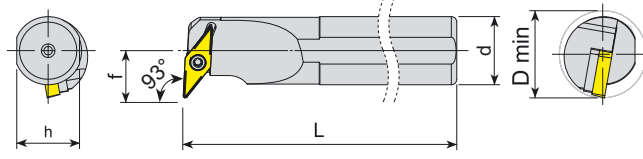

| Takım Kodu Ordering Code | Stok Stock | | Takım Ölçüleri (mm) Dimension (mm) | | | | | Kesici Uç Insert | Yedek Parçaları Spare Parts | | | |
|-----------------------------|---------------|---|---------------------------------------|------|-----|----|-------|---------------------|--------------------------------|---------------|----------------------------|--------------------------|
| | R | L | d | h | L | f | D min | | Sıkma Vidası Screw | Altık Shim | Altık Vidası Shim Screw | Tork Anahtar Torx Key |
| S16P SVUBR/L 11 | ● | ● | 16 | 14.8 | 170 | 11 | ≥21 | VBM. 1103.. | 4008-M2.5x6 | - | - | 80-T08 |
| S20R SVUBR/L 11 | ● | ● | 20 | 18.3 | 200 | 13 | ≥25 | | | | | |
| S25S SVUBR/L 16 | ● | ● | 25 | 23 | 250 | 17 | ≥32 | VBM. 1604.. | 4015-M3.5x14 | AAVN-2-0002 | AAV-06-M3.5x11 | 80-T15 |
| S32T SVUBR/L 16 | ● | ● | 32 | 30 | 300 | 22 | ≥40 | | | | | |
| S40U SVUBR/L 16 | ● | ● | 40 | 37.5 | 350 | 27 | ≥50 | | | | | |

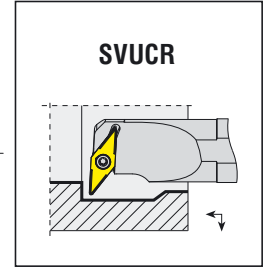
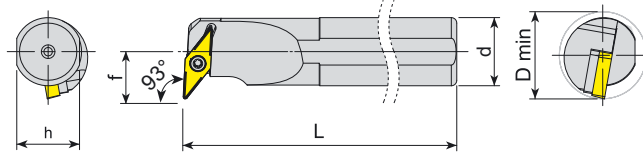

| Takım Kodu Ordering Code | Stok Stock | | Takım Ölçüleri (mm) Dimension (mm) | | | | | Kesici Uç Insert | Yedek Parçaları Spare Parts | | | |
|-----------------------------|---------------|---|---------------------------------------|------|-----|----|-------|---------------------|--------------------------------|---------------|----------------------------|--------------------------|
| | R | L | d | h | L | f | D min | | Sıkma Vidası Screw | Altık Shim | Altık Vidası Shim Screw | Tork Anahtar Torx Key |
| S16P SVUCR/L 11 | ● | ● | 16 | 14.8 | 170 | 11 | ≥21 | VC.T 1103.. | 4008-M2.5x6 | - | - | 80-T08 |
| S20R SVUCR/L 11 | ● | ● | 20 | 18.3 | 200 | 13 | ≥25 | | | | | |
| S25S SVUCR/L 16 | ● | ● | 25 | 23 | 250 | 17 | ≥32 | VC.T 1604.. | 4015-M3.5x14 | AAVN-2-0002 | AAV-06-M3.5x11 | 80-T15 |
| S32T SVUCR/L 16 | ● | ● | 32 | 30 | 300 | 22 | ≥40 | | | | | |
| S40U SVUCR/L 16 | ● | ● | 40 | 37.5 | 350 | 27 | ≥50 | | | | | |

R: Sağ/Right L: Sol/Left ● Stokta/In Stock ○ Stokta Yok/Non Stock Item

Sipariş Örneği/Ordering Example : 1 ad./pcs. S16P SVUBR 11

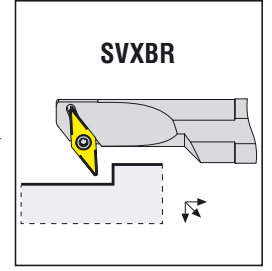
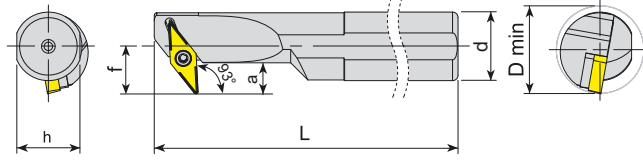

| Takım Kodu Ordering Code | Stok Stock | | Takım Ölçüleri (mm) Dimension (mm) | | | | | Kesici Uç Insert | Yedek Parçaları Spare Parts | | | | |
|-----------------------------|---------------|---|---------------------------------------|------|-----|----|-----|---------------------|--------------------------------|-----------------------|---------------|----------------------------|--------------------------|
| | R | L | d | h | L | f | a | | D min | Sıkma Vidası Screw | Altık Shim | Altık Vidası Shim Screw | Tork Anahtar Torx Key |
| S16P SVXBR/L 11 | ○ | ○ | 16 | 14.8 | 170 | 11 | 6 | ≥21 | VBM. 1103.. | 4008-M2.5x6 | - | - | 80-T08 |
| S20R SVXBR/L 11 | ○ | ○ | 20 | 18.3 | 200 | 13 | 6 | ≥25 | | | | | |
| S25S SVXBR/L 16 | ● | ● | 25 | 23 | 250 | 17 | 8.5 | ≥32 | VBM. 1604.. | 4015-M3.5x14 | AAVN-2-0002 | AAV-06-M3.5x11 | 80-T15 |
| S32T SVXBR/L 16 | ● | ● | 32 | 30 | 300 | 22 | 12 | ≥40 | | | | | |
| S40U SVXBR/L 16 | ● | ● | 40 | 37.5 | 350 | 27 | 14 | ≥50 | | | | | |

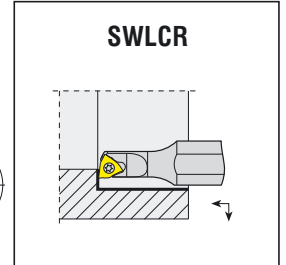
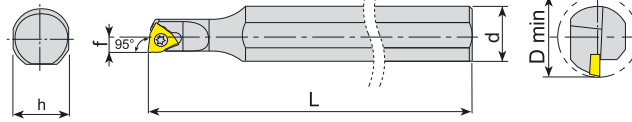

| Takım Kodu Ordering Code | Stok Stock | | Takım Ölçüleri (mm) Dimension (mm) | | | | | Kesici Uç Insert | Yedek Parçaları Spare Parts | | | |
|-----------------------------|---------------|---|---------------------------------------|-----|-----|----|-------|---------------------|--------------------------------|---------------|----------------------------|--------------------------|
| | R | L | d | h | L | f | D min | | Sıkma Vidası Screw | Altık Shim | Altık Vidası Shim Screw | Tork Anahtar Torx Key |
| S0608H SWLCR 03 | ● | ○ | 08 | 7.3 | 100 | 04 | ≥08 | WC.. 0302.. | 4008-M2.5x4 | - | - | 80-T08 |
| S0810K SWLCR 03 | ● | ○ | 10 | 09 | 125 | 07 | ≥10 | | | | | |

R: Sağ/Right L: Sol/Left ● Stokta/In Stock ○ Stokta Yok/Non Stock Item

Sipariş Örneği/Ordering Example : 1 ad./pcs. S16P SVXBR 11

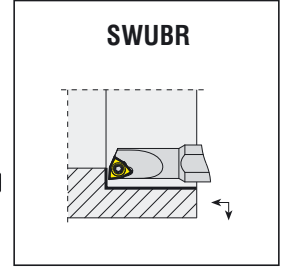
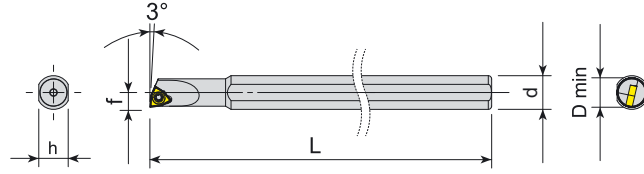

Takım Kodu
Ordering Code

Stok
Stock

Takım Ölçüleri (mm)
Dimension (mm)

Kesici Uç
Insert

Yedek Parçaları
Spare Parts

Sıkma Vidası
Screw

Altık
Shim

Altık Vidası
Shim Screw

Tork Anahtar
Torx Key

d h L f D min

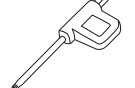

| | | | | | | | | | | | |
|-------------------|---|----|-----|-----|------|------|-------------|-------------|---|---|--------|
| S08H SWUBR 06-5.5 | ● | 08 | 7.3 | 100 | 2.75 | ≥5.5 | WBGT 060102 | 3006-M2x3.6 | - | - | 80-T06 |
| S08H SWUBR 06-7 | ● | 08 | 7.3 | 100 | 3.5 | ≥7 | | 3006-M2x4 | - | - | |

R: Sağ/Right L: Sol/Left ● Stokta/In Stock ○ Stokta Yok/Non Stock Item

Sipariş Örneği/Ordering Example : 1 ad./pcs. S08H SWUBR 06-5.5





*konusulan
the spoken kalite...
quality...*

KARTUŞLAR

KARTUŞLAR
CARTRIDGE





S

1

T

2

F

3

C

4

R

5

12

6

C

7

A

8

16

9

1 Sıkma Tipi / Method of Mounting of Insert



Deliksiz Üstten Sıkma
Top clamping without hole

C

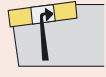

Delikten Laveyle Sıkma
Hole Clamping (Lever Lock)

P

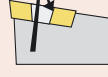

Vida ile Sıkma
Screw on

S

2 Uç Tipi / Insert Shape



C



S



T

3 Yanaşma Açısı / ToolHolder Shape

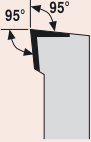

L



S



F

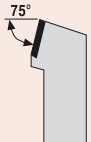

R



K

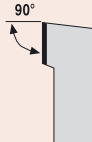

G



W

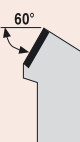

T

4 Serbest Uç Açısı / Clearance angle of Insert



C



P



N

5 Kesme Yönü / Cutting Direction

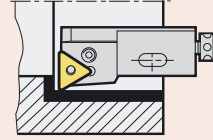

R

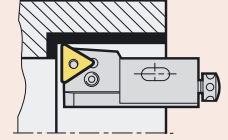

L

6 Kesme Kenar Yüksekliği / Cutting Edge Height

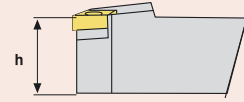

7 Kartuş Kodu / Cartridge Code

C
(Kartuş / Cartridge)

8 Kartuş Tipi / Type of Cartridge

A
(ISO 5611)

9 Kesme Kenar Uzunluğu / Cutting Edge Length

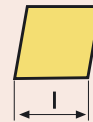

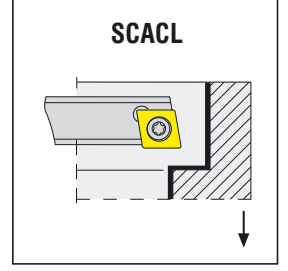
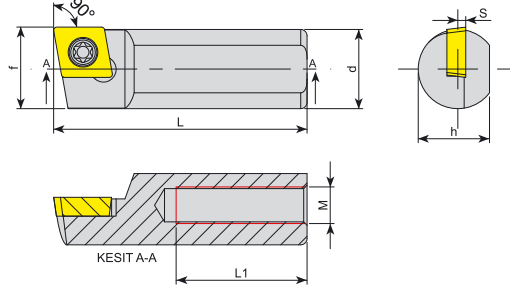



| Takım Kodu Ordering Code | Stok Stock | | Takım Ölçüleri (mm) Dimension (mm) | | | | | | | Kesici Uç Insert | Yedek Parçaları Spare Parts | |
|-----------------------------|---------------|---|---------------------------------------|------|-----|----|---|------|---------|---------------------|--------------------------------|---------------------------|
| | R | L | d | h | L | L1 | S | f | M | | Sıkma Vidası Screw | Tork Anahtarı Torx Key |
| S10X SCACR/L 06 | ● | ● | 10 | 9 | 25 | 10 | 1 | 10.3 | M5x0.8 | CC.. 0602.. | 4008-M2.5x6 | 80-T08 |
| S10A SCACR/L 06 | ● | ● | 10 | 9 | 32 | 15 | 1 | 10.3 | M5x0.8 | | | |
| S10C SCACR/L 06 | ● | ● | 10 | 9 | 50 | 25 | 1 | 10.3 | M5x0.8 | | | |
| S12B SCACR/L 06 | ● | ● | 12 | 11 | 40 | 25 | 1 | 12.3 | M5x0.8 | | | |
| S15C SCACR/L 09 | ○ | ● | 15 | 14 | 50 | 25 | 2 | 15.3 | M8x1.25 | CC.. 09T3.. | 4015-M3.5x8 | 80-T15 |
| S15E SCACR/L 09 | ○ | ● | 15 | 14 | 70 | 45 | 2 | 15.3 | M8x1.25 | | | |
| S15D SCACR/L 09 | ○ | ● | 15 | 14 | 60 | 30 | 2 | 15.3 | M8x1.25 | | | |
| S16A SCACR/L 09 | ● | ● | 16 | 15 | 32 | 15 | 2 | 16.5 | M6x1 | | | |
| S16B SCACR/L 09 | ● | ● | 16 | 15 | 40 | 20 | 2 | 16.5 | M6x1 | | | |
| S16C SCACR/L 09 | ○ | ● | 16 | 15 | 50 | 25 | 2 | 16.5 | M6x1 | | | |
| S16D SCACR/L 09 | ● | ● | 16 | 15 | 60 | 30 | 2 | 16.5 | M6x1 | | | |
| S16E SCACR/L 09 | ○ | ● | 16 | 15 | 70 | 30 | 2 | 16.5 | M6x1 | | | |
| S16G SCACR/L 09 | ● | ● | 16 | 15 | 90 | 30 | 2 | 16.5 | M6x1 | | | |
| S16H SCACR/L 09 | ○ | ● | 16 | 15 | 100 | 35 | 4 | 16.5 | M6x1 | | | |
| S18E SCACR/L 09 | ○ | ● | 18 | 17 | 70 | 30 | 2 | 18.5 | M8x1.25 | CC.. 1204.. | 1020-M5x11 | 80-T20 |
| S20E SCACR/L 09 | ● | ● | 20 | 18.3 | 70 | 30 | 2 | 20.5 | M6x1 | | | |
| S20H SCACR/L 12 | ● | ● | 20 | 18.3 | 100 | 30 | 2 | 20.5 | M6x1 | | | |

R: Sağ/Right L: Sol/Left ● Stokta/In Stock ○ Stokta Yok/Non Stock Item

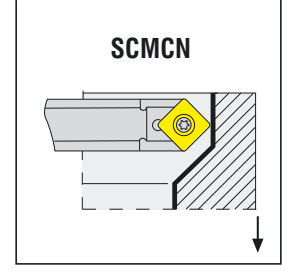
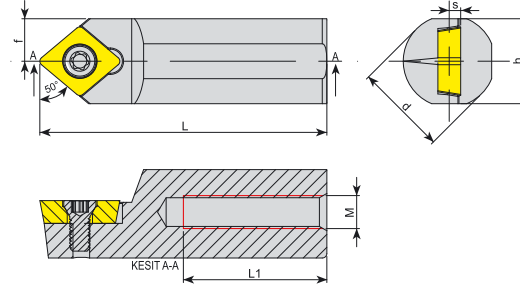

Sipariş Örneği/Ordering Example : 1 ad./pcs. S10X SCACR 06



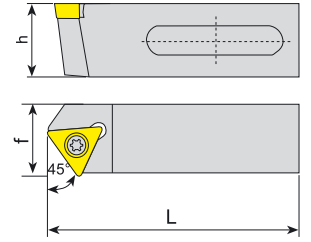

| Takım Kodu Ordering Code | Stok Stock | Takım Ölçüleri (mm) Dimension (mm) | | | | | | Kesici Uç Insert | Yedek Parçaları Spare Parts | | |
|-----------------------------|---------------|---------------------------------------|----|----|----|---|---|---------------------|--|---|---|
| | | d | h | L | L1 | S | f | | M | Sıkma Vidası Screw | Tork Anahtar Torx Key |
| S10X SCMCN 06 | ● | 10 | 9 | 25 | 10 | 1 | 5 | M5x0.8 |  |  |  |
| S16C SCMCN 09 | ● | 16 | 15 | 50 | 25 | 2 | 8 | M6x1 | CC.. 0602.. | 4008-M2.5x6 | 80-T08 |
| S16D SCMCN 09 | ● | 16 | 15 | 60 | 25 | 4 | 8 | M6x1 | CC.. 09T3.. | 4015-M3.5x11 | 80-T15 |



| Takım Kodu Ordering Code | Stok Stock | | Takım Ölçüleri (mm) Dimension (mm) | | | | Kesici Uç Insert | Yedek Parçaları Spare Parts | |
|-----------------------------|---------------|---|---------------------------------------|----|----|----|---|---|---|
| | R | L | d | h | L | f | | Sıkma Vidası Screw | Tork Anahtar Torx Key |
| STXCR/L 2020 B16 | ○ | ● | 20 | 20 | 40 | 20 |  |  |  |
| STXCR/L 2020 E16 | ○ | ● | 20 | 20 | 70 | 20 | | | |
| STXCR/L 2020 B16-SA | ○ | ● | 20 | 20 | 40 | 20 | | | |
| STXCR/L 2020 E16-SA | ○ | ● | 20 | 20 | 70 | 20 | | | |
| | | | | | | | TC.. 16T3.. | 4015-M3.5x11 | 80-T15 |

R: Sağ/Right L: Sol/Left ● Stokta/In Stock ○ Stokta Yok/Non Stock Item

Sipariş Örneği/Ordering Example : 1 ad./pcs. S10X SCMCN 06

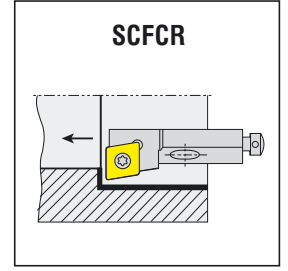
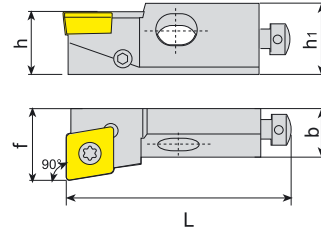
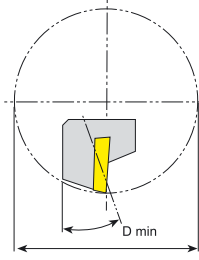

| Takım Kodu Ordering Code | Stok Stock | | Takım Ölçüleri (mm) Dimension (mm) | | | | | Kesici Uç Insert | Yedek Parçaları Spare Parts | | | | |
|-----------------------------|---------------|---|---------------------------------------|-----|----|----|----|---------------------|--------------------------------|---------------|----------------------------|-----------------------|--------------------------|
| | R | L | h | h1 | b | L | f | | D min | Altık Shim | Altık Vidası Shim Screw | Sıkma Vidası Screw | Tork Anahtar Torx Key |
| SCFCR/L 06CA 06 | ● | ● | 6 | 8.5 | 6 | 25 | 8 | ≥20 | CC.T 0602.. | - | - | 4008-M2.5x6 | 80-T08 |
| SCFCR/L 08CA 06 | ● | ● | 8 | 11 | 8 | 32 | 10 | ≥20 | CC.T 09T3.. | - | - | 4015-M3.5x11 | 80-T15 |
| SCFCR/L 10CA 09 | ● | ● | 10 | 15 | 11 | 50 | 14 | ≥40 | CC.T 1204.. | AACN-2-0003 | AAV-10-M4.5x8 | 4020-M4.5x12 | 80-T20 |
| SCFCR/L 12CA 12 | ○ | ○ | 12 | 18 | 15 | 55 | 20 | ≥50 | | | | | |
| SCFCR/L 16CA 12 | ○ | ○ | 16 | 21 | 20 | 63 | 25 | ≥60 | | | | | |

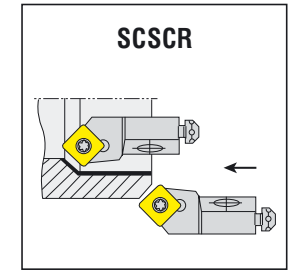
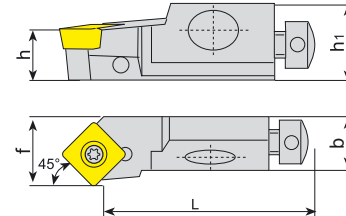
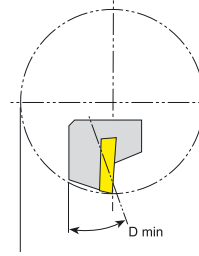
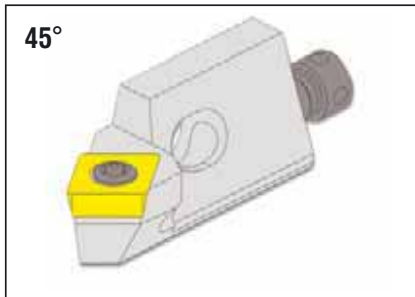

| Takım Kodu Ordering Code | Stok Stock | | Takım Ölçüleri (mm) Dimension (mm) | | | | | Kesici Uç Insert | Yedek Parçaları Spare Parts | | | | |
|-----------------------------|---------------|---|---------------------------------------|----|----|----|----|---------------------|--------------------------------|---------------|----------------------------|-----------------------|--------------------------|
| | R | L | h | h1 | b | L | f | | D min | Altık Shim | Altık Vidası Shim Screw | Sıkma Vidası Screw | Tork Anahtar Torx Key |
| SCSCR/L 06CA 06 | ○ | ○ | 6 | 8 | 6 | 21 | 8 | ≥20 | CC.T 0602.. | - | - | 4008-M2.5x6 | 80-T08 |
| SCSCR/L 10CA 09 | ○ | ○ | 10 | 15 | 11 | 44 | 14 | ≥40 | CC.T 09T3.. | AACN-2-0001 | AAV-06-M3.5x11 | 4015-M3.5x14 | 80-T15 |
| SCSCR/L 12CA 12 | ○ | ○ | 12 | 18 | 15 | 47 | 20 | ≥50 | CC.T 1204.. | AACN-2-0003 | AAV-07-M4.5x13 | 1020-M4.5x16 | 80-T20 |

R: Sağ/Right L: Sol/Left ● Stokta/In Stock ○ Stokta Yok/Non Stock Item

Sipariş Örneği/Ordering Example : 1 ad./pcs. SCFCR 06CA 06

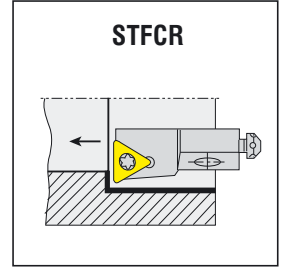
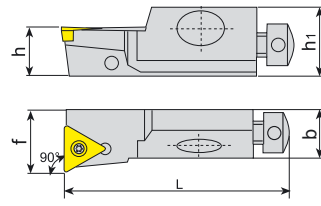
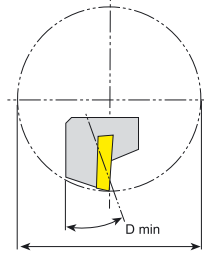

| Takım Kodu Ordering Code | Stok Stock | | Takım Ölçüleri (mm) Dimension (mm) | | | | | | Kesici Uç Insert | Yedek Parçaları Spare Parts | | | |
|-----------------------------|---------------|---|---------------------------------------|----|----|----|----|-------|---------------------|--------------------------------|-----------------------------|-----------------------|--------------------------|
| | R | L | h | h1 | b | L | f | D min | | Altlık Shim | Altlık Vidası Shim Screw | Sıkma Vidası Screw | Tork Anahtar Torx Key |
| STFCR/L 10CA 11 | ● | ● | 10 | 15 | 11 | 50 | 14 | ≥40 | TC.T 1102.. | - | - | 4008-M2.5x6 | 80-T08 |
| STFCR/L 12CA 16 | ● | ○ | 12 | 20 | 15 | 55 | 20 | ≥50 | TC.T 16T3.. | - | - | 4015-M3.5x11 | 80-T15 |
| STFCR/L 16CA 16 | ○ | ○ | 16 | 21 | 20 | 63 | 20 | ≥60 | | AATN-2-0001 | AAV-06-M3.5x11 | 4015-M3.5x14 | |

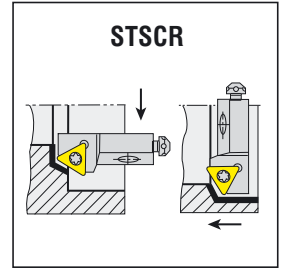
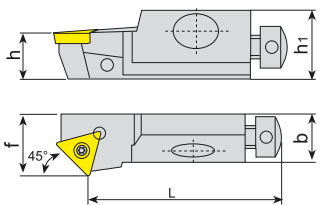
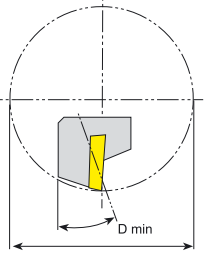

| Takım Kodu Ordering Code | Stok Stock | | Takım Ölçüleri (mm) Dimension (mm) | | | | | | Kesici Uç Insert | Yedek Parçaları Spare Parts | | | |
|-----------------------------|---------------|---|---------------------------------------|----|----|----|----|-------|---------------------|--------------------------------|-----------------------------|-----------------------|--------------------------|
| | R | L | h | h1 | b | L | f | D min | | Altlık Shim | Altlık Vidası Shim Screw | Sıkma Vidası Screw | Tork Anahtar Torx Key |
| STSCR/L 08CA 09 | ○ | ○ | 8 | 11 | 8 | 28 | 10 | ≥20 | TC.T 0902.. | - | - | 3007-M2.2x5 | 80-T07 |
| STSCR/L 10CA 11 | ● | ● | 10 | 15 | 11 | 44 | 14 | ≥40 | TC.T 1102.. | - | - | 4008-M2.5x6 | 80-T08 |
| STSCR/L 12CA 16 | ● | ○ | 12 | 20 | 15 | 55 | 20 | ≥50 | TC.T 16T3.. | - | - | 4015-M3.5x11 | 80-T15 |

R: Sağ/Right L: Sol/Left ● Stokta/In Stock ○ Stokta Yok/Non Stock Item

Sipariş Örneği/Ordering Example : 1 ad./pcs. STFCR 10CA 11

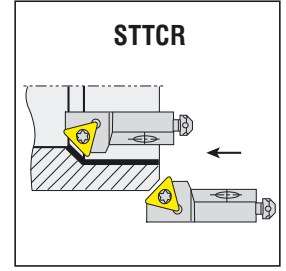
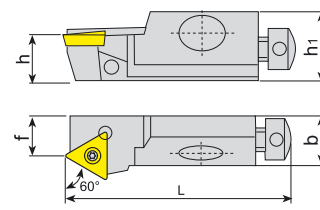
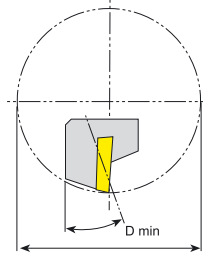
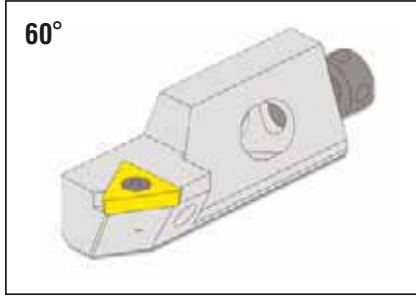

| Takım Kodu Ordering Code | Stok Stock | | Takım Ölçüleri (mm) Dimension (mm) | | | | | | Kesici Uç Insert | Yedek Parçaları Spare Parts | | | |
|-----------------------------|---------------|---|---------------------------------------|-----|-----|------|------|-------|---------------------|--------------------------------|----------------------------|-----------------------|--------------------------|
| | R | L | h | h1 | b | L | f | D min | | Altık Shim | Altık Vidası Shim Screw | Sıkma Vidası Screw | Tork Anahtar Torx Key |
| STTCR/L 08CA 09 | ○ | ○ | 8 | 9.5 | 6.5 | 25.7 | 10 | ≥20 | | | | | |
| STTCR/L 10CA 11 | ○ | ○ | 10 | 15 | 11 | 42 | 13.9 | ≥40 | | - | - | 3007-M2.2x5 | 80-T07 |
| | | | | | | | | | | - | - | 4008-M2.5x6 | 80-T08 |

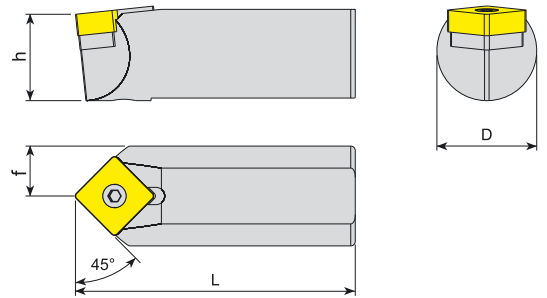
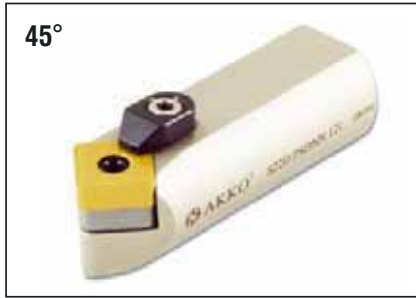

| Takım Kodu Ordering Code | Stok Stock | Takım Ölçüleri (mm) Dimension (mm) | | | | Kesici Uç Insert | Yedek Parçaları Spare Parts | | | | |
|-----------------------------|---------------|---------------------------------------|------|----|----|---------------------|--------------------------------|-----------------------------|------------------------------|-----------------------------|----------------------|
| | | d | h | L | f | | Altık Shim | Sıkma Vidası Clamp Screw | Baskı Parçası Wedge Clamp | Baskı Vidası Clamp Screw | Anahtar Allen Key |
| S22D PSDNN 12C | ● | 22 | 19.5 | 60 | 11 | | | | | | |
| | | | | | | | AASN-20020 | AEV-01-M6x16 | ACK-05 | 1515-M4x11 | AAL-02-2.5 |

R: Sağ/Right L: Sol/Left ● Stokta/In Stock ○ Stokta Yok/Non Stock Item

Sipariş Örneği/Ordering Example : 1 ad./pcs. STTCR 08CA 09



| Takım Kodu Ordering Code | | Yedek Parçaları Spare Parts | | | | |
|----------------------------------|---------|---------------------------------------|---------------------------------------|---|-------------------------------|---|
| | | Eksenel Ayar Vida Axial Adj. Screw | Radyal Ayar Vida Radial Adj. Screw | Radyal Ayar Vida Anahtar Radial Adj. Screw Allen Key | Montaj Vida Mounting Screw | Montaj Vida Anahtar Mounting Screw Allen Key |
| SCFCR/L SCSCR/L | 06CA 06 | 2600-M4x9.5 | 2715-M3x5 | AAL-09-1.5 | 2503-M4x10 | AAL-03-3 |
| | 08CA 06 | 2600-M4x9.5 | 2715-M3x5 | AAL-09-1.5 | 2503-M4x10 | AAL-03-3 |
| | 10CA 09 | 2600-M5x13 | 2702-M4X10 | AAL-01-2 | 2505-M6X20 | AAL-07-5 |
| | 12CA 12 | 2600-M5x13 | 2702-M4X10 | AAL-01-2 | 2505-M6X20 | AAL-07-5 |
| | 16CA 12 | 2600-M6x18 | 2725-M5X12 | AAL-02-2.5 | 2506-M8X30 | AAL-08-6 |
| STSCR/L | 08CA 09 | 2600-M4x9.5 | 2715-M3x5 | AAL-09-1.5 | 2503-M4x10 | AAL-03-3 |
| STTCR/L | 10CA 11 | 2600-M5x13 | 2702-M4X10 | AAL-01-2 | 2505-M6X20 | AAL-07-5 |
| STFCR/L | 12CA 16 | 2600-M5x13 | 2702-M4X10 | AAL-01-2 | 2505-M6X20 | AAL-07-5 |
| | 16CA 16 | 2600-M6x18 | 2725-M5X12 | AAL-02-2.5 | 2506-M8X30 | AAL-08-6 |





*konusulan
the spoken kalite...
quality...*

DİŞ AÇMA

DİŞ AÇMA TAKIMLARI
THREADING TOOLHOLDERS





S **E** **R** **25 25** **M** **16** **C**

1 Sıkma Tipi
Method of Mounting of Insert

S: Vida Sıkmalı
S: Screw Clamping
T: Vida Sıkmalı Helis Açılı
T: Screw Clamping with Helix Angle

2 İşlem Tipi
Application

E: Dış / External
I: İç / Internal

3 Kesme Yönü
Cutting Direction

R: Sağ Yan / Right - Hand
L: Sol Yan / Left - Hand

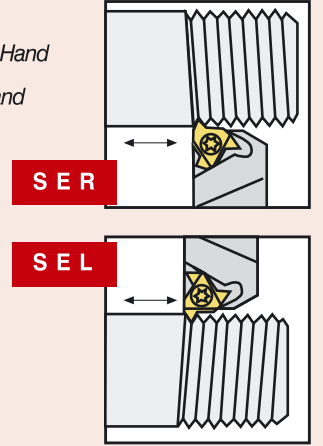

4 Takım Malzemesi / Type of Boring Bar

"A" Yekpare çelik gövde soğutma suyu kanallı / "A" Solid steel with coolant hole
"E" Çelik başlıkla sert metal gövde ve soğutma suyu kanallı /
"E" Carbide bar with fixed steel head and coolant hole
"C" Karbür Şaft / "C" Carbide shank
"S" Çelik Şaft / "S" Steel shank

4-5 Dış Çap Şaft Ölçüleri
External Shank Size

Şaft : hxb / Shank : hxb
2525 - 25 x 25 mm

5 Şaft Çapı / Shank Diameter

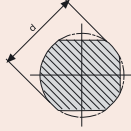

6 Şaft Boyu / Shank Length

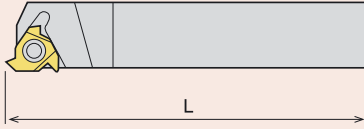

| | | | (mm) |
|--------|---------|---------|-----------|
| A - 32 | H - 100 | Q - 180 | x-special |
| B - 40 | J - 110 | R - 200 | |
| C - 50 | K - 125 | S - 250 | |
| D - 60 | L - 140 | T - 300 | |
| E - 70 | M - 150 | U - 350 | |
| F - 80 | N - 160 | V - 400 | |
| G - 90 | P - 170 | W - 450 | |

7 Elmas Ölçüsü
Insert Size

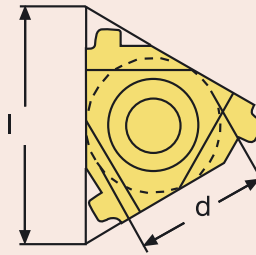

| l (mm) | d |
|--------|-------|
| 06 | 5/32" |
| 08 | 3/16" |
| 11 | 1/4" |
| 16 | 3/8" |
| 22 | 1/2" |
| 27 | 5/8" |

8 Baskı Pabucu
Wedge Clamp

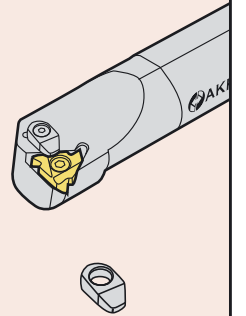

S **I** **R** **S** **25** **R** **16** **C**

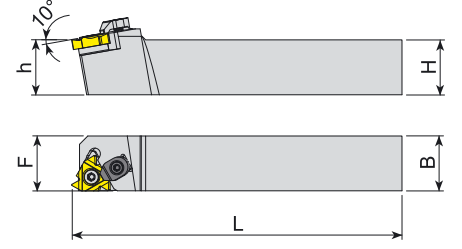
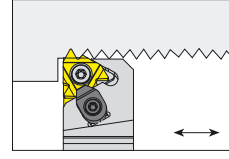

| Takım Kodu Ordering Code | Stok Stock | | Takım Ölçüleri (mm) Dimension (mm) | | | | Kesici Uç Insert | Yedek Parçaları Spare Parts | | | | | |
|-----------------------------|---------------|---|---------------------------------------|----|-----|----|---------------------------------------|--------------------------------|----------------|-----------------------------|------------------------------|-----------------------------|--------------------------|
| | R | L | h=H | B | L | F | | Sıkma Vidası Screw | Altlık Shim | Altlık Vidası Shim Screw | Baskı Parçası Wedge Clamp | Baskı Vidası Clamp Screw | Tork Anahtar Torx Key |
| SER/L 0808 E11 | ● | ● | 08 | 08 | 70 | 11 | 11 ER/EL | 4008-M2.5x6 | - | - | - | - | 80-T08 |
| SER/L 1010 E11 | ● | ● | 10 | 10 | 70 | 11 | | | | | | | |
| SER/L 1616 H11 | ● | ● | 16 | 16 | 100 | 16 | | | | | | | |
| SER/L 1616 H16C | ● | ● | 16 | 16 | 100 | 16 | 16 ER/EL (0.35 - 3) ISO METRIC | 4015-M3.5x14 | AATN-2-0020 | AAV-06-M3.5x11 | ACK-05 | 1515 M4x11 | 80-T15 |
| SER/L 2020 K16C | ● | ● | 20 | 20 | 125 | 20 | | | | | | | |
| SER/L 2525 M16C | ● | ● | 25 | 25 | 150 | 25 | | | | | | | |
| SER/L 3232 P16C | ● | ● | 32 | 32 | 170 | 32 | | | | | | | |
| SER/L 2525 M22C | ● | ● | 25 | 25 | 150 | 25 | 22 ER/EL (3.5 - 4.5) ISO METRIC | 1020-M4.5x16 | AATN-2-0004 | AAV-07-M4.5x13 | ACK-05 | 1515 M4x11 | 80-T20 |
| SER/L 3232 P22C | ● | ● | 32 | 32 | 170 | 32 | | | | | | | |
| SER/L 4040 S22C | ● | ● | 40 | 40 | 250 | 40 | 16 ER/L (1.5-3 TR) | 4015-M3.5x14 | - | - | - | - | 80-T15 |
| SER/L 2525 M16C-T | ● | ● | 25 | 25 | 150 | 25 | | | | | | | |
| SER/L 2525 M22C-T | ● | ● | 25 | 25 | 150 | 25 | | | | | | | |
| SER/L 2020 K16C-S | ● | ● | 20 | 20 | 125 | 20 | SNDVK 166 ER/L16 | 4015-M3.5x14 | AATN-2-0020 | AAV-06-M3.5x11 | ACK-05 | 1515 M4x11 | 80-T15 |
| SER/L 2525 M16C-S | ● | ● | 25 | 25 | 150 | 25 | | | | | | | |
| SER/L 3232 P16C-S | ● | ● | 32 | 32 | 170 | 32 | | | | | | | |

R: Sağ/Right L: Sol/Left ● Stokta/In Stock ○ Stokta Yok/Non Stock Item

Takımlar standart 1.5° helis açılı olarak üretilir. / The tools have a built in 1.5° helix angle.

UYARI / WARNING

Sayfa 96'daki B ve D figürleri uygulanamaz. / The operation for B and D on page 96 can not be applied.

Sipariş Örneği/Ordering Example : 1 ad./pcs. SER 0808 E11

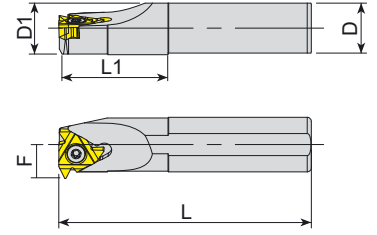
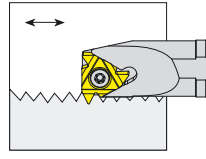

| Takım Kodu Ordering Code | Stok Stock | | Takım Ölçüleri (mm) Dimension (mm) | | | | | Kesici Uç Insert | Yedek Parçaları Spare Parts | | | | | | | | | | | | |
|-----------------------------|---------------|---|---------------------------------------|----|-----|----|------|---------------------|-------------------------------------|--------------------------------------|----------------|-----------------------------|------------------------------|-----------------------------|--------------------------|--------------|----------------|----------------|------------|---------------|---------------|
| | R | L | D | D1 | L | L1 | F | | D min | Sıkma Vidası Screw | Altlık Shim | Altlık Vidası Shim Screw | Baskı Parçası Wedge Clamp | Baskı Vidası Clamp Screw | Tork Anahtar Torx Key | | | | | | |
| SIR/L S16X07M 08 | ● | ● | 16 | 07 | 150 | 18 | 5.3 | 7.8 | 08 IR/L | 3007-M2.2x5 | - | - | - | - | 80-T07 | | | | | | |
| SIR/L S10H 11 | ● | ● | 10 | 10 | 100 | - | 7.4 | 12 | 11 IR/L | 4008-M2.5x6 | - | - | - | - | 80-T08 | | | | | | |
| SIR/L S12K 11 | ● | ● | 12 | 12 | 125 | - | 8.4 | 16 | | | | | | | | | | | | | |
| SIR/L S16X10M 11 | ● | ● | 16 | 10 | 150 | 25 | 7.4 | 12 | | | | | | | | | | | | | |
| SIR/L S16X13M 11 | ● | ● | 16 | 13 | 150 | 32 | 8.9 | 15 | | | | | | | | | | | | | |
| SIR/L S16M 11 | ● | ● | 16 | 16 | 150 | - | 11.7 | 19 | | | | | | | | | | | | | |
| SIR/L S16X13M 16 | ● | ● | 16 | 13 | 150 | 32 | 10.2 | 16 | 16 IR/L (0.35 - 3) ISO METRIC | 4015-M3.5x9 | - | - | - | - | 80-T15 | | | | | | |
| SIR/L S16M 16 | ● | ● | 16 | 16 | 150 | - | 11.7 | 19 | | 4015-M3.5x11 | | | | | | | | | | | |
| SIR/L S20X16P 16 | ● | ● | 20 | 16 | 170 | 40 | 11.7 | 19 | | 4015-M3.5x12 | | | | | | AATN-2-0020 | AAV-06-M3.5x11 | ACK-05 | 1515-M4x11 | | |
| SIR/L S20P 16 | ● | ● | 20 | 20 | 170 | - | 13.7 | 24 | | | | | | | | | | | | | |
| SIR/L S25R 16C | ● | ● | 25 | 25 | 200 | - | 16.2 | 29 | | | | | | | | | | | | AAV-08-M3.5x8 | |
| SIR/L S32S 16C | ● | ● | 32 | 32 | 250 | - | 19.7 | 36 | | | | | | | | | | | | | |
| SIR/L S40T 16C | ● | ● | 40 | 40 | 300 | - | 23.7 | 44 | | 4015-M3.5x14 | | | | | | AATN-2-0020 | AAV-06-M3.5x11 | ACK-05 | 1515-M4x11 | | |
| SIR/L S50U 16C | ● | ● | 50 | 50 | 350 | - | 28.7 | 54 | | 22 IR/L (3.5 - 4.5) ISO METRIC | | | | | | 1020-M4.5x16 | AATN-2-0004 | AAV-07-M4.5x13 | ACK-05 | 1515-M4x11 | |
| SIR/L S20P 22 | ● | ● | 20 | 20 | 170 | - | 14 | 24 | | | | | | | | | | | | | 4020-M4.5x12 |
| SIR/L S25R 22C | ● | ● | 25 | 25 | 200 | - | 18.1 | 29 | | | | | | | | | | | | | AAV-10-M4.5x8 |
| SIR/L S32S 22C | ● | ● | 32 | 32 | 250 | - | 21.6 | 38 | | | | | | | | | | | | | |
| SIR/L S40T 22C | ● | ● | 40 | 40 | 300 | - | 25.6 | 46 | 1020-M4.5x16 | | AATN-2-0004 | AAV-07-M4.5x13 | ACK-05 | 1515-M4x11 | | | | | | | |
| SIR/L S50U 22C | ● | ● | 50 | 50 | 350 | - | 30.6 | 58 | 16 IR/L (1.5-3 TR) | 4015-M3.5x14 | - | - | - | 80-T15 | | | | | | | |
| SIR/L S25R 16C-T | ● | ● | 25 | 25 | 200 | - | 16.2 | 29 | | | | | | | | | | | | | |
| SIR/L S32S 16C-T | ● | ● | 32 | 32 | 250 | - | 19.7 | 36 | | | | | | | | | | | | | |
| SIR/L S25R 22C-T | ● | ● | 25 | 25 | 200 | - | 18.1 | 29 | 22 IR/L (4-6 TR) | 4020-M4.5x12 | - | - | - | 80-T20 | | | | | | | |
| SIR/L S32S 22C-T | ● | ● | 32 | 32 | 250 | - | 21.6 | 38 | | 1020-M4.5x16 | | | | | | | | | | | |

R: Sağ/Right L: Sol/Left ● Stokta/In Stock ○ Stokta Yok/Non Stock Item
Takımlar standart 1.5° helis açılı olarak üretilir. / The tools have a built in 1.5° helix angle.

Sipariş Örneği/Ordering Example : 1 ad./pcs. SIR S16X07M 08

UYARI / WARNING

Sayfa 97'deki B ve D figürleri uygulanamaz. / The operation for B and D on page 97 can not be applied.

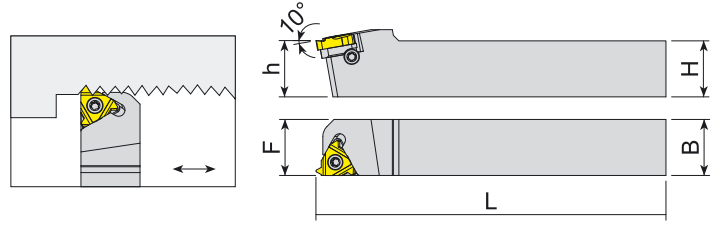

| Takım Kodu Ordering Code | Stok Stock | | Takım Ölçüleri (mm) Dimension (mm) | | | | Kesici Uç Insert | Yedek Parçaları Spare Parts | | | | | | |
|-----------------------------|---------------|---|---------------------------------------|----|-----|----|---------------------|--------------------------------|--------------------------|-------------------------|-----------------------------|------------------------------|-----------------------------|--------------------------|
| | R | L | h=H | B | L | F | | Sıkma Vidası Screw | Sağ Altlık Right Shim | Sol Altlık Left Shim | Altlık Vidası Shim Screw | Baskı Parçası Wedge Clamp | Baskı Vidası Clamp Screw | Tork Anahtar Torx Key |
| TER/L 1616 H16 | ● | ● | 16 | 16 | 100 | 16 | 16 ER/EL | 1710-U5-40x12.2 | ATS-16E | ATS-16I | AAV-11-U5-40x4.5 | - | - | 80-T10 |
| TER/L 2020 K16 | ● | ● | 20 | 20 | 125 | 20 | | | | | | | | |
| TER/L 2525 M16 | ● | ● | 25 | 25 | 150 | 25 | | | | | | | | |
| TER/L 3232 P16 | ● | ● | 32 | 32 | 170 | 32 | | | | | | | | |
| TER/L 2525 M22 | ● | ● | 25 | 25 | 150 | 25 | 22 ER/EL | 1720-U8-32x15 | ATS-22E | ATS-22I | AAV-12-U8-32x5.5 | - | - | 80-T20 |
| TER/L 3232 P22 | ● | ● | 32 | 32 | 170 | 32 | | | | | | | | |
| TER/L 4040 S22 | ● | ● | 40 | 40 | 250 | 40 | | | | | | | | |
| TER/L 3232 P27 | ○ | ○ | 32 | 32 | 170 | 32 | 27 ER/EL | S27 | ATS-27E | ATS-27I | 1315-M3.5x11 | - | - | 80-T20 |
| TER/L 4040 S27 | ○ | ○ | 40 | 40 | 250 | 40 | | | | | | | | |

R: Sağ/Right L: Sol/Left ● Stokta/In Stock ○ Stokta Yok/Non Stock Item
Takımlar standart 1.5° helis açılı olarak üretilir. / The tools have a built in 1.5° helix angle.

Sipariş Örneği/Ordering Example : 1 ad./pcs. TER 1616 H16

DIŞ ÇAP SAĞ YÖNDE VİDA AÇMA
EXTERNAL RIGHT HAND THREADING OPERATION

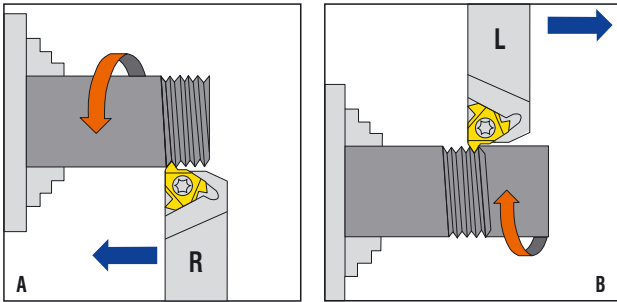

DIŞ ÇAP SOL YÖNDE VİDA AÇMA
EXTERNAL LEFT HAND THREADING OPERATION

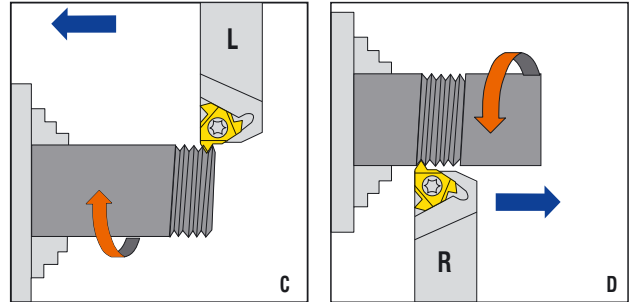

UYARI / WARNING

Figür B ve D için; negatif açılı altlık kullanılmalıdır. / For figure B and D; negative shim must be used.
Altıksız katerlerde B ve D figürü uygulanamaz. / B and D figures can not be applied on tools without shim.

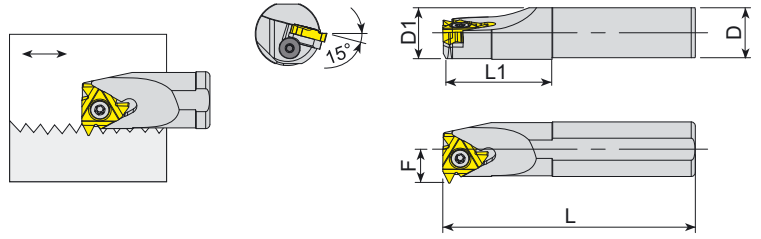

| Takım Kodu Ordering Code | Stok Stock | | Takım Ölçüleri (mm) Dimension (mm) | | | | | Kesici Uç Insert | Yedek Parçaları Spare Parts | | | | | | | |
|-----------------------------|---------------|---|---------------------------------------|----|-----|----|------|---------------------|--------------------------------|-----------------------|-------------------------|--------------------------|-----------------------------|------------------------------|-----------------------------|--------------------------|
| | R | L | D | D1 | L | L1 | F | | D min | Sıkma Vidası Screw | Sol Altlık Left Shim | Sağ Altlık Right Shim | Altlık Vidası Shim Screw | Baskı Parçası Wedge Clamp | Baskı Vidası Clamp Screw | Tork Anahtar Torx Key |
| TIR/L S25R 16 | ● | ● | 25 | 25 | 200 | - | 16.2 | 29 | 16 IR/L | 1710-U5-40x12.2 | ATS-16E | ATS-16I | AAV-11-U5-40x4.5 | - | - | 80-T10 |
| TIR/L S32S 16 | ● | ● | 32 | 32 | 250 | - | 19.7 | 36 | | | | | | | | |
| TIR/L S40T 16 | ● | ● | 40 | 40 | 300 | - | 23.7 | 44 | | | | | | | | |
| TIR/L S50U 16 | ● | ● | 50 | 50 | 350 | - | 28.7 | 54 | | | | | | | | |
| TIR/L S25R 22 | ● | ● | 25 | 25 | 200 | - | 18.1 | 29 | 22 IR/L | 1720-U8-32x15 | ATS-22E | ATS-22I | AAV-12-U8-32x5.5 | - | - | 80-T20 |
| TIR/L S32S 22 | ● | ● | 32 | 32 | 250 | - | 21.6 | 38 | | | | | | | | |
| TIR/L S40T 22 | ● | ● | 40 | 40 | 300 | - | 25.6 | 46 | | | | | | | | |
| TIR/L S50U 22 | ● | ● | 50 | 50 | 350 | - | 30.6 | 58 | | | | | | | | |
| TIR/L S32S 27 | ○ | ○ | 32 | 32 | 250 | - | 22.6 | 40 | 27 IR/L | S27 | ATS-27E | ATS-27I | 1315-M3.5x11 | - | - | 80-T20 |
| TIR/L S40T 27 | ○ | ○ | 40 | 40 | 300 | - | 26.6 | 48 | | | | | | | | |
| TIR/L S50U 27 | ○ | ○ | 50 | 50 | 350 | - | 31.6 | 58 | | | | | | | | |

R: Sağ/Right L: Sol/Left ● Stokta/In Stock ○ Stokta Yok/Non Stock Item

Takımlar standart 1.5° helis açılı olarak üretilir. / The tools have a built in 1.5° helix angle.

Sipariş Örneği/Ordering Example : 1 ad./pcs. TIR S25R 16

DELİK İÇİ SAĞ YÖNDE VİDA AÇMA
INTERNAL RIGHT HAND THREADING OPERATION

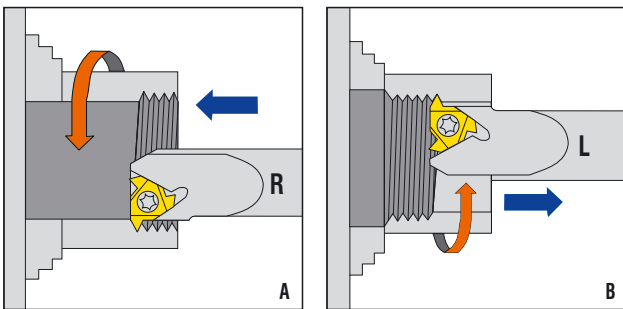

DELİK İÇİ SOL YÖNDE VİDA AÇMA
INTERNAL LEFT HAND THREADING OPERATION

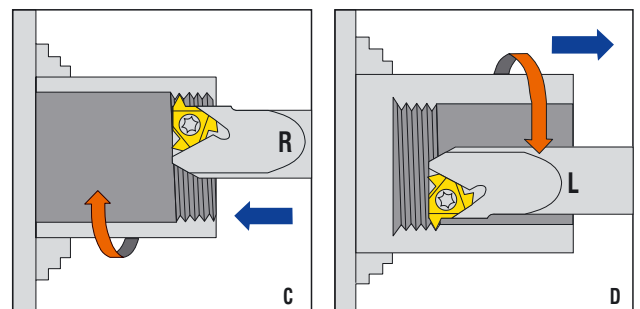

UYARI / WARNING

Figür B ve D için; negatif açılı altlık kullanılmalıdır. / For figure B and D; negative shim must be used.
Altıksız katerlerde B ve D figürü uygulanamaz. / B and D figures can not be applied on tools without shim.

Diş Helis Açısı Thread Helix Angle

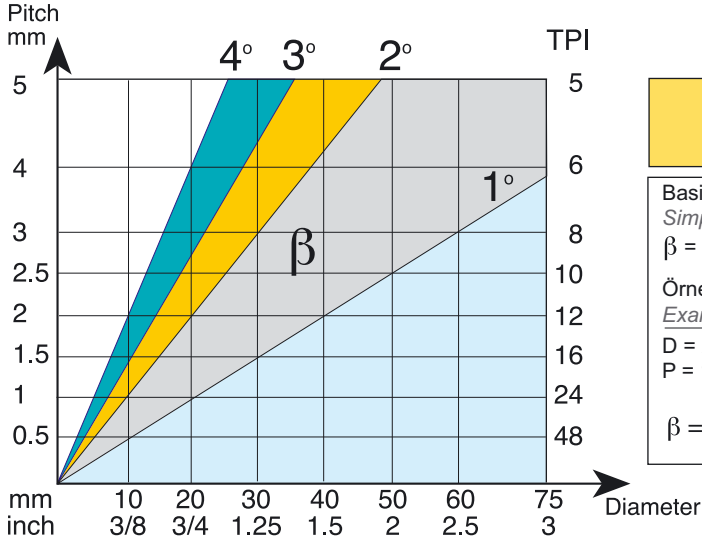

$$\tan \beta = \frac{P}{\pi \times D}$$

Basitleştirilmiş formül
Simplified formula
 $\beta = 20 P/D$

Örnek :
Example:

D = 25 mm (0.98")
P = 1.5 mm (16 TPI)

$$\beta = \frac{25 \times 1.5}{40} = 1.25^\circ$$

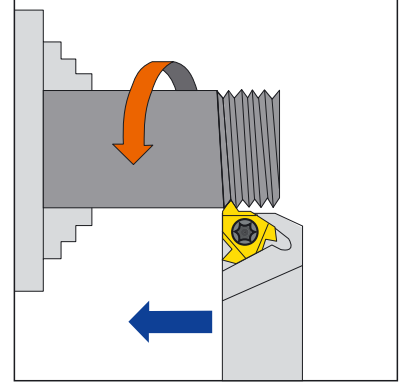

Standart ve Eğik Altlıklar Standard and Slanted Shim

Akko diş açma takımlarının, uç yuvaları 1.5° helis açılı olarak üretilir. Farklı helis açılı diş açmak isteyenler altlığı değiştirerek istedikleri dereceyi elde edebilirler. Negatif helis genellikle sol katerde sağ diş çekmek için kullanılır ya da sağ katerde sol diş çekmek için kullanılır.

Akko Toolholders Pockets have a built in 1.5° helix angle. This angle may be adjusted to better match the thread helix angle by simply changing the shim. Negative helix is usually used when threading RH thread with LH Holder or LH thread with RH Holder.

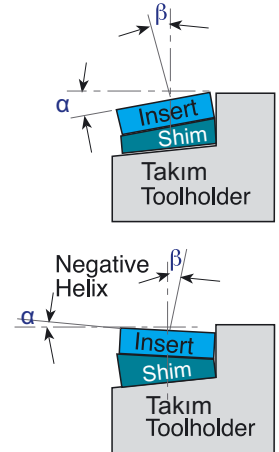

| L | IC | Takım Tipi Tool Type | Uç Yuvasının Açısı (α) Pocket's Angle (α) | | | | | | |
|----|-----|-------------------------|--|-------------|-------------|---------|-------------|-------------|-------------|
| | | | 4.5° | 3.5° | 2.5° | 1.5° | 0.5° | -0.5° | -1.5° |
| 16 | 3/8 | EX-RH or IN-LH | ATS-16E+4.5 | ATS-16E+3.5 | ATS-16E+2.5 | ATS-16E | ATS-16E+0.5 | ATS-16E-0.5 | ATS-16E-1.5 |
| 16 | 3/8 | EX-RH or IN-LH | ATS-16I+4.5 | ATS-16I+3.5 | ATS-16I+2.5 | ATS-16I | ATS-16I+0.5 | ATS-16I-0.5 | ATS-16I-1.5 |
| 22 | 1/2 | EX-RH or IN-LH | ATS-22E+4.5 | ATS-22E+3.5 | ATS-22E+2.5 | ATS-22E | ATS-22E+0.5 | ATS-22E-0.5 | ATS-22E-1.5 |
| 22 | 1/2 | EX-RH or IN-LH | ATS-22I+4.5 | ATS-22I+3.5 | ATS-22I+2.5 | ATS-22I | ATS-22I+0.5 | ATS-22I-0.5 | ATS-22I-1.5 |
| 27 | 5/8 | EX-RH or IN-LH | ATS-27E+4.5 | ATS-27E+3.5 | ATS-27E+2.5 | ATS-27E | ATS-27E+0.5 | ATS-27E-0.5 | ATS-27E-1.5 |
| 27 | 5/8 | EX-RH or IN-LH | ATS-27I+4.5 | ATS-27I+3.5 | ATS-27I+2.5 | ATS-27I | ATS-27I+0.5 | ATS-27I-0.5 | ATS-27I-1.5 |

Altlık Değişirme Öneri Tablosu / Shim Change Recommendation

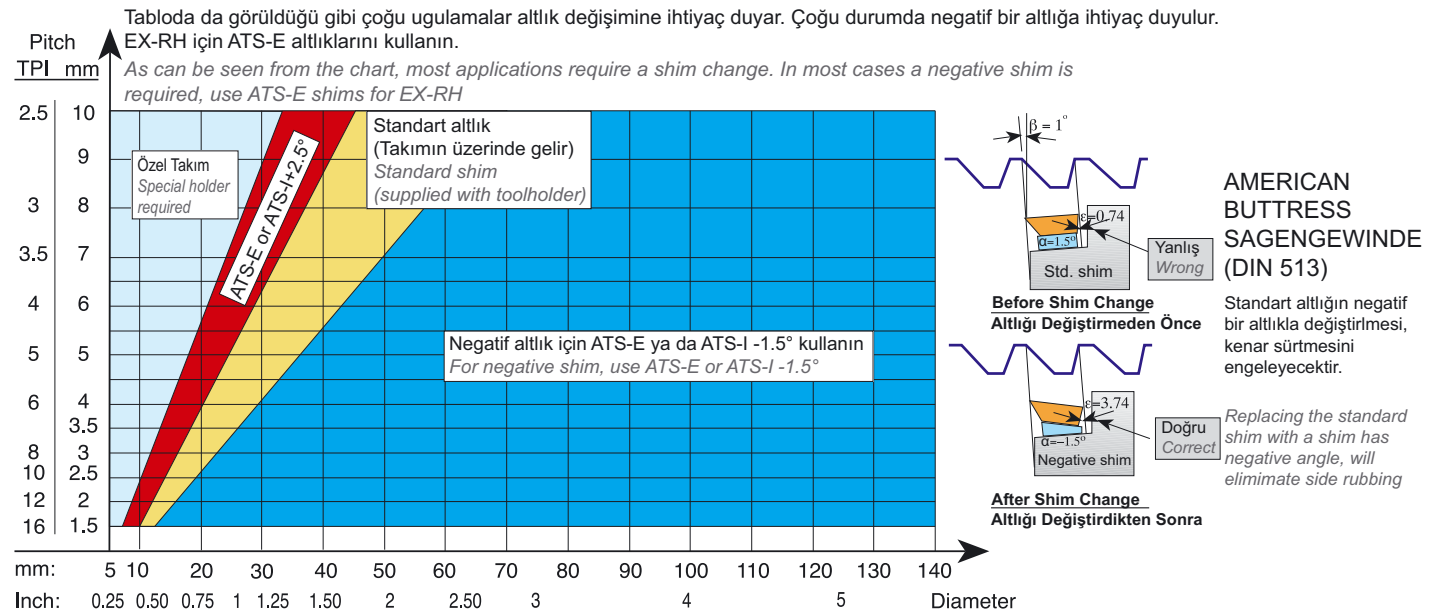
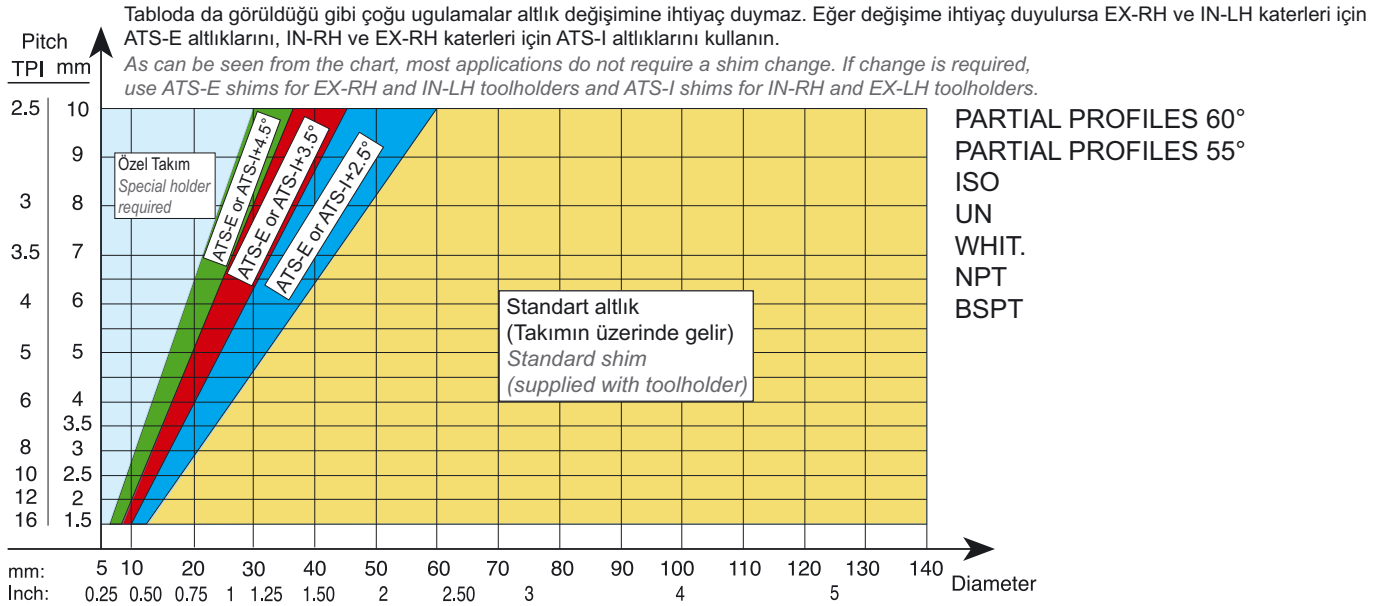
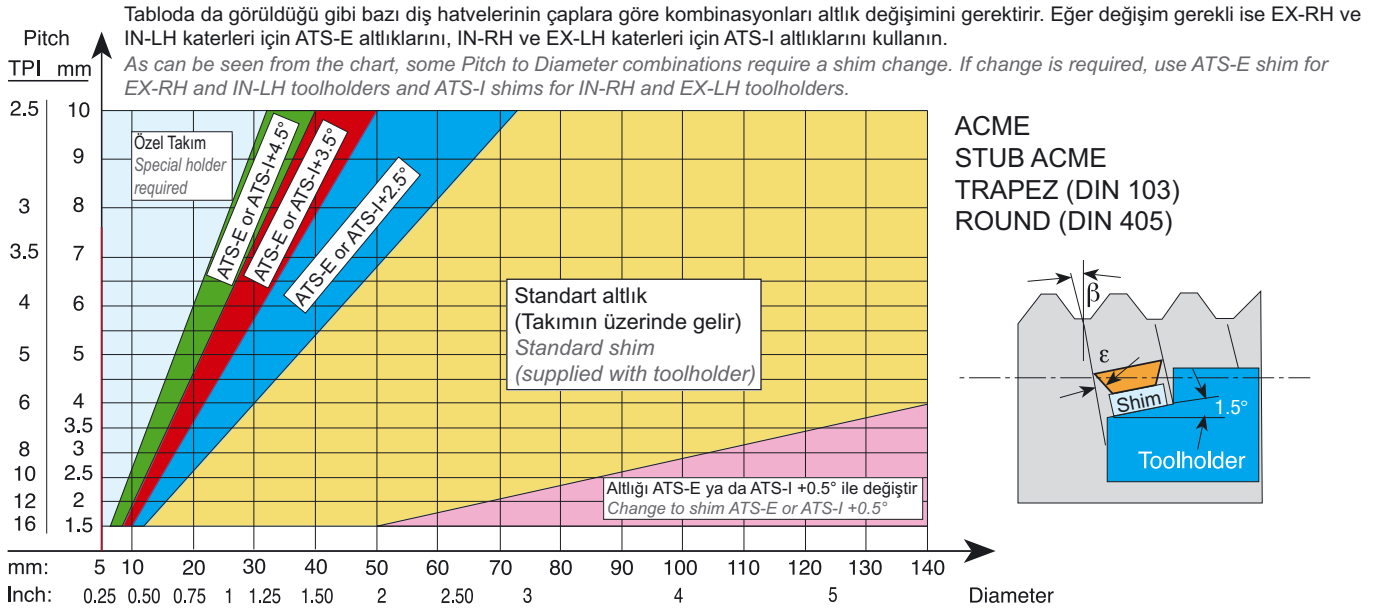



*konusulan
the spoken kalite...
quality...*

KANAL AÇMA

KANAL AÇMA TAKIMLARI
GROOVING TOOLHOLDERS





AKKO **A** **AKT** - **K** - **R** - **2525**

100 - **150** - **4** - **T22**

2 Kesiş Stili / Cutter Style

DKT : Dış Çap Kanal Açma Takımı - External Grooving Toolholders
IKT : Delik İçi Kanal Açma Takımı - Internal Grooving Toolholders
AKT : Dış Çap Alın Kanal Açma Takımı - Face Grooving Toolholders
LKT : L Tip Alın Kanal Açma Takımları - L Type Face Grooving Toolholders

3 Uç Tipi / Insert Type

KRLY / MGM.
HRN / S312, S229, S224, S223
ISCR / DGN, GI, GTN
SNDVK / 123, 151, 154.91
ZCC
KM / A4.
ARN / LOMR.

TGTC / TD.

4 Kesme Yönü / Cutting Direction

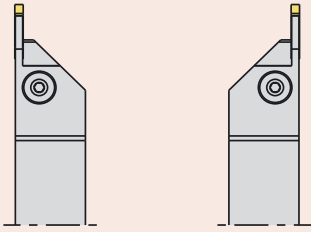

R

L

5 Kesme Kenar Yüksekliği ve Şaft Geniřlięi Cutting Edge Height and Shank Width

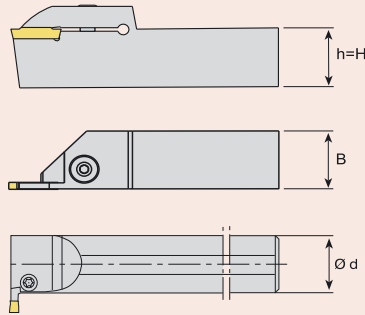

6 Kesme Aralıęı / Cutting Diameter

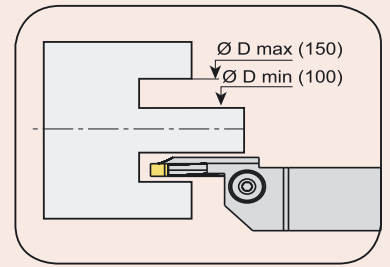

7 Kesme Kenar Geniřlięi / Cutting Width Edge

ÖR/E.G :
2 = 2.0 mm
3 = 3.0 mm
4 = 4.0 mm
5 = 5.0 mm
6 = 6.0 mm
8 = 8.0 mm

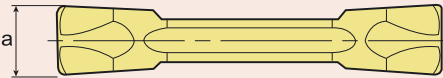

8 Kesme Derinlięi / Cutting Depth

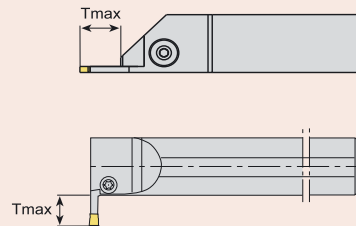

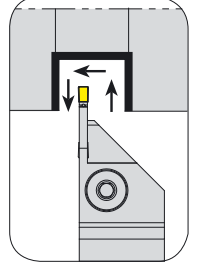
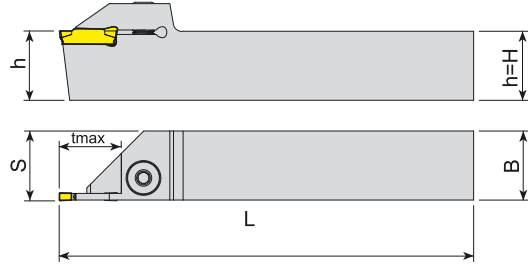

| Takım Kodu Ordering Code | Stok Stock | | Takım Ölçüleri (mm) Dimension (mm) | | | | | Kesici Uç Insert | Yedek Parçaları Spare Parts | | |
|-----------------------------|---------------|---|---------------------------------------|----|-----|------|------------------|---------------------|--------------------------------|--------------|----------------------|
| | R | L | h=H | B | L | S | t _{max} | | Sıkma Vidası Clamp Screw | Pul Stamp | Anahtar Allen Key |
| ADKT-K-R/L-1212-2-T15 | ● | ● | 12 | 12 | 100 | 12.3 | 15 | MGM. - 2 | AKV-02-M6x22 | ABPL-01 | AAL-03-3 |
| ADKT-K-R/L-1616-2-T15 | ● | ● | 16 | 16 | 100 | 16.3 | 15 | | | | |
| ADKT-K-R/L-2020-2-T15 | ● | ● | 20 | 20 | 125 | 20.3 | 15 | | | | |
| ADKT-K-R/L-2525-2-T15 | ● | ● | 25 | 25 | 150 | 25.3 | 15 | | | | |
| ADKT-K-R/L-3232-2-T15 | ○ | ○ | 32 | 32 | 170 | 32.3 | 15 | | | | |
| ADKT-K-R/L-1212-3-T15 | ● | ● | 12 | 12 | 100 | 12.3 | 15 | MGM. - 3 | | | |
| ADKT-K-R/L-1616-3-T15 | ● | ● | 16 | 16 | 100 | 16.4 | 15 | | | | |
| ADKT-K-R/L-2020-3-T20 | ● | ● | 20 | 20 | 125 | 20.4 | 20 | | | | |
| ADKT-K-R/L-2525-3-T22 | ● | ● | 25 | 25 | 150 | 25.4 | 22 | | | | |
| ADKT-K-R/L-3232-3-T22 | ● | ● | 32 | 32 | 170 | 32.4 | 22 | | | | |
| ADKT-K-R/L-2020-4-T20 | ● | ● | 20 | 20 | 125 | 20.4 | 20 | MGM. - 4 | 2004-M8x1x20 | - | AAL-05-4 |
| ADKT-K-R/L-2525-4-T18 | ● | ● | 25 | 25 | 150 | 25.4 | 18 | | | | |
| ADKT-K-R/L-2525-4-T22 | ● | ● | 25 | 25 | 150 | 25.4 | 22 | | | | |
| ADKT-K-R/L-3232-4-T22 | ● | ● | 32 | 32 | 170 | 32.4 | 22 | | | | |
| ADKT-K-R/L-2020-5-T20 | ● | ● | 20 | 20 | 125 | 20.5 | 20 | MGM. - 5 | | | |
| ADKT-K-R/L-2525-5-T18 | ● | ● | 25 | 25 | 150 | 25.5 | 18 | | | | |
| ADKT-K-R/L-2525-5-T25 | ● | ● | 25 | 25 | 150 | 25.5 | 25 | | | | |
| ADKT-K-R/L-3232-5-T25 | ● | ● | 32 | 32 | 170 | 32.5 | 25 | | | | |
| ADKT-K-R/L-2525-6-T25 | ● | ○ | 25 | 25 | 150 | 25.6 | 25 | MGM. - 6 | | | |
| ADKT-K-R/L-3232-6-T25 | ● | ● | 32 | 32 | 170 | 32.6 | 25 | | | | |
| ADKT-K-R/L-3232-8-T32 | ● | ● | 32 | 32 | 170 | 32.8 | 32 | MGM. - 8 | | | |

R: Sağ/Right L: Sol/Left ● Stokta/In Stock ○ Stokta Yok/Non Stock Item
KRLY - JD Ucuna Uygunudur. / Compatible with KRLY - JD Insert.

Sipariş Örneği/Ordering Example : 1 ad./pcs. ADKT-K-R-1212-2-T15

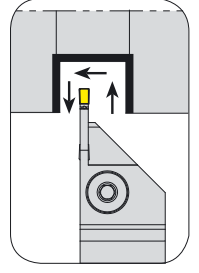
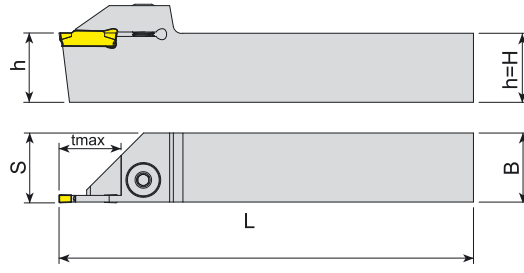

| Takım Kodu Ordering Code | Stok Stock | | Takım Ölçüleri (mm) Dimension (mm) | | | | | Kesici Uç Insert | Yedek Parçaları Spare Parts | | |
|-----------------------------|---------------|---|---------------------------------------|----|-----|------|-------|---------------------|--------------------------------|--------------|----------------------|
| | R | L | h=H | B | L | S | t max | | Sıkma Vidası Clamp Screw | Pul Stamp | Anahtar Allen Key |
| ADKT-KG-R/L-2020-2-T15 | ○ | ○ | 20 | 20 | 125 | 20.2 | 15 | KG.. - 2 | AKV-02-M6x22 | ABPL-01 | AAL-03-3 |
| ADKT-KG-R/L-2525-2-T15 | ○ | ○ | 25 | 25 | 150 | 25.2 | 15 | | | | |
| ADKT-KG-R/L-2020-3-T20 | ○ | ○ | 20 | 20 | 125 | 20.3 | 20 | KG.. - 3 | 2004-M8x1x20 | - | AAL-05-4 |
| ADKT-KG-R/L-2525-3-T22 | ○ | ○ | 25 | 25 | 150 | 25.3 | 22 | | | | |
| ADKT-KG-R/L-2020-4-T20 | ○ | ○ | 20 | 20 | 125 | 20.4 | 20 | KG.. - 4 | 2004-M8x1x20 | - | AAL-05-4 |
| ADKT-KG-R/L-2525-4-T22 | ○ | ○ | 25 | 25 | 150 | 25.4 | 22 | | | | |
| ADKT-KG-R/L-2525-5-T25 | ○ | ○ | 25 | 25 | 150 | 25.5 | 25 | KG.. - 5 | | | |
| ADKT-KG-R/L-2525-6-T25 | ○ | ○ | 25 | 25 | 150 | 25.6 | 25 | KG.. - 6 | | | |

KRLY Ucuna Uygun. / Compatible with KRLY Insert.

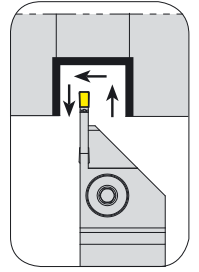
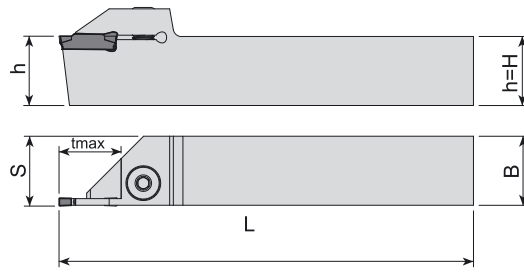

| Takım Kodu Ordering Code | Stok Stock | | Takım Ölçüleri (mm) Dimension (mm) | | | | | Kesici Uç Insert | Yedek Parçaları Spare Parts | | |
|-----------------------------|---------------|---|---------------------------------------|----|-----|------|-------|---------------------|--------------------------------|--------------|----------------------|
| | R | L | h=H | B | L | S | t max | | Sıkma Vidası Clamp Screw | Pul Stamp | Anahtar Allen Key |
| ADKT-SGC-R/L-1212-2-R15 | ● | ○ | 12 | 12 | 100 | 12.2 | 15 | GCM N20 | AKV-02-M6x22 | ABPL-01 | AAL-03-3 |
| ADKT-SGC-R/L-1616-2-R15 | ● | ○ | 16 | 16 | 100 | 16.2 | 15 | | | | |
| ADKT-SGC-R/L-2020-2-R20 | ● | ○ | 20 | 20 | 125 | 20.2 | 20 | GCM N30 | 2004-M8x1x20 | - | AAL-05-4 |
| ADKT-SGC-R/L-2525-2-R20 | ● | ○ | 25 | 25 | 150 | 25.2 | 20 | | | | |
| ADKT-SGC-R/L-1212-3-R15 | ● | ○ | 12 | 12 | 100 | 12.3 | 15 | GCM N30 | 2004-M8x1x20 | - | AAL-05-4 |
| ADKT-SGC-R/L-1616-3-R15 | ● | ○ | 16 | 16 | 100 | 16.3 | 15 | | | | |
| ADKT-SGC-R/L-2020-3-R22 | ● | ○ | 20 | 20 | 125 | 20.3 | 22 | | | | |
| ADKT-SGC-R/L-2525-3-R15 | ● | ○ | 25 | 25 | 150 | 25.3 | 15 | | | | |
| ADKT-SGC-R/L-2525-3-R22 | ● | ○ | 25 | 25 | 150 | 25.3 | 22 | | | | |

R: Sağ/Right L: Sol/Left ● Stokta/In Stock ○ Stokta Yok/Non Stock Item
SMTM Ucuna Uygun. / Compatible with SMTM Insert.

Sipariş Örneği/Ordering Example : 1 ad./pcs. ADKT-KG-R-2020-2-T15

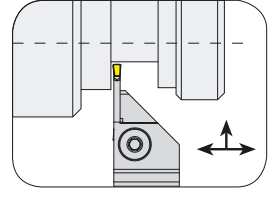
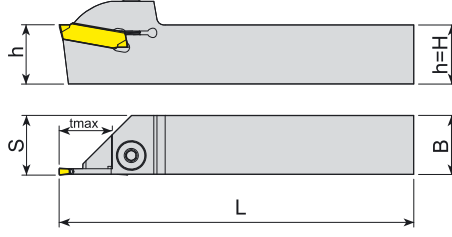

| Takım Kodu Ordering Code | Stok Stock | | Takım Ölçüleri (mm) Dimension (mm) | | | | | Kesici Uç Insert | Yedek Parçaları Spare Parts | | |
|-----------------------------|---------------|---|---------------------------------------|----|-----|------|-------|---------------------|--------------------------------|--------------|----------------------|
| | R | L | h=H | B | L | S | t max | | Sıkma Vidası Clamp Screw | Pul Stamp | Anahtar Allen Key |
| ADKT-H-R/L-2020-3-T20 | ● | ● | 20 | 20 | 125 | 20.5 | 20 | S229 - 3 | 2004-M8x1x20 | - | AAL-05-4 |
| ADKT-H-R/L-2525-3-T22 | ● | ● | 25 | 25 | 150 | 25.5 | 22 | | | | |
| ADKT-H-R/L-2020-4-T20 | ● | ● | 20 | 20 | 125 | 20.5 | 20 | | | | |
| ADKT-H-R/L-2525-4-T22 | ● | ● | 25 | 25 | 150 | 25.5 | 22 | | | | |
| ADKT-H-R/L-3232-4-T22 | ● | ● | 32 | 32 | 170 | 32.5 | 22 | S229 - 4 | | | |
| ADKT-H-R/L-2020-5-T20 | ● | ● | 20 | 20 | 125 | 20.5 | 20 | S229 - 5 | | | |
| ADKT-H-R/L-2525-5-T25 | ● | ● | 25 | 25 | 150 | 25.5 | 25 | S229 - 6 | | | |
| ADKT-H-R/L-2525-6-T25 | ● | ● | 25 | 25 | 150 | 25.6 | 25 | | | | |

HRN Ucuna Uygunudur. / Compatible with HRN Insert.

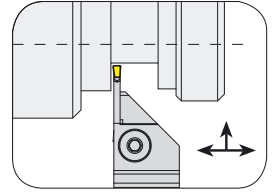
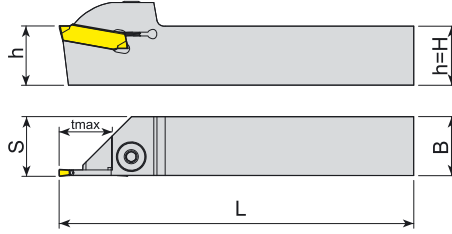

| Takım Kodu Ordering Code | Stok Stock | | Takım Ölçüleri (mm) Dimension (mm) | | | | | Kesici Uç Insert | Yedek Parçaları Spare Parts | | |
|-----------------------------|---------------|---|---------------------------------------|----|-----|------|-------|---------------------|--------------------------------|--------------|----------------------|
| | R | L | h=H | B | L | S | t max | | Sıkma Vidası Clamp Screw | Pul Stamp | Anahtar Allen Key |
| ADKT-HK-R/L-1616-2-T15 | ● | ● | 16 | 16 | 100 | 16.3 | 15 | S224 - 2 | AKV-02-M6x22 | ABPL-01 | AAL-03-3 |
| ADKT-HK-R/L-2020-2-T15 | ● | ● | 20 | 20 | 125 | 20.3 | 15 | | | | |
| ADKT-HK-R/L-2525-2-T15 | ● | ● | 25 | 25 | 150 | 25.3 | 15 | S224 - 3 | 2004-M8x1x20 | - | AAL-05-4 |
| ADKT-HK-R/L-1616-3-T15 | ○ | ○ | 16 | 16 | 100 | 16.3 | 15 | | | | |
| ADKT-HK-R/L-2020-3-T20 | ● | ● | 20 | 20 | 125 | 20.4 | 20 | | | | |
| ADKT-HK-R/L-2525-3-T22 | ● | ● | 25 | 25 | 150 | 25.4 | 22 | | | | |
| ADKT-HK-R/L-2020-4-T20 | ● | ● | 20 | 20 | 125 | 20.4 | 20 | S224 - 4 | | | |
| ADKT-HK-R/L-2525-4-T22 | ● | ● | 25 | 25 | 150 | 25.4 | 22 | S223 - 2 | AKV-02-M6x22 | ABPL-01 | AAL-03-3 |
| ADKT-HS223-R/L-2020-2-T15 | ● | ○ | 20 | 20 | 125 | 20.4 | 15 | | | | |

R: Sağ/Right L: Sol/Left ● Stokta/In Stock ○ Stokta Yok/Non Stock Item
HRN Ucuna Uygunudur. / Compatible with HRN Insert.

Sipariş Örneği/Ordering Example : 1 ad./pcs. ADKT-HK-R-1616-2-T15

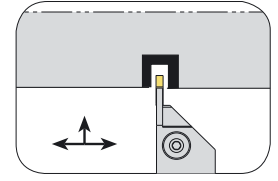
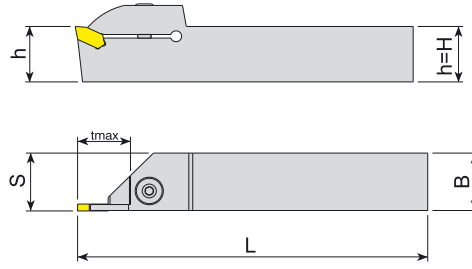

| Takım Kodu Ordering Code | Stok Stock | | Takım Ölçüleri (mm) Dimension (mm) | | | | | Kesici Uç Insert | Yedek Parçaları Spare Parts | | |
|-----------------------------|---------------|---|---------------------------------------|----|-----|------|-------|---------------------|--------------------------------|--------------|----------------------|
| | R | L | h=H | B | L | S | t max | | Sıkma Vidası Clamp Screw | Pul Stamp | Anahtar Allen Key |
| ADKT-ZCC1-R/L-2020-3-T20 | ● | ○ | 20 | 20 | 125 | 20.3 | 20 | ZQMX - 3 | 2004-M8x1x20 | - | AAL-05-4 |
| ADKT-ZCC1-R/L-2525-3-T22 | ● | ○ | 25 | 25 | 150 | 25.3 | 22 | | | | |
| ADKT-ZCC1-R/L-2020-4-T20 | ● | ○ | 20 | 20 | 125 | 20.4 | 20 | ZQMX - 4 | 2004-M8x1x20 | - | AAL-05-4 |
| ADKT-ZCC1-R/L-2525-4-T22 | ● | ○ | 25 | 25 | 150 | 25.4 | 22 | | | | |

ZCC Ucuna Uygundur. / Compatible with ZCC Insert.

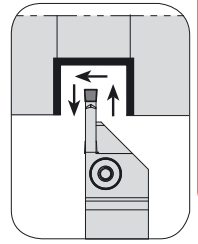
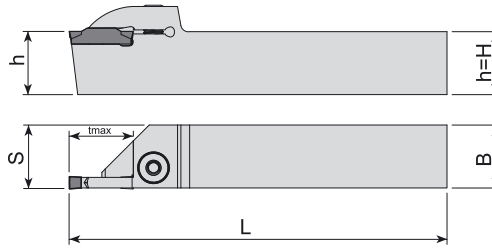

| Takım Kodu Ordering Code | Stok Stock | | Takım Ölçüleri (mm) Dimension (mm) | | | | | Kesici Uç Insert | Yedek Parçaları Spare Parts | | |
|-----------------------------|---------------|---|---------------------------------------|----|-----|------|-------|---------------------|--------------------------------|--------------|----------------------|
| | R | L | h=H | B | L | S | t max | | Sıkma Vidası Clamp Screw | Pul Stamp | Anahtar Allen Key |
| ADKT-ZCC2-R/L-2020-2-T15 | ● | ● | 20 | 20 | 125 | 20.3 | 15 | ZT.D - 2 | AKV-02-M6x22 | ABPL-01 | AAL-03-3 |
| ADKT-ZCC2-R/L-2525-2-T15 | ● | ● | 25 | 25 | 150 | 25.3 | 15 | | | | |
| ADKT-ZCC2-R/L-2525-2.5-T15 | ● | ● | 25 | 25 | 150 | 25.3 | 15 | ZT.D - 2.5 | 2004-M8x1x20 | - | AAL-05-4 |
| ADKT-ZCC2-R/L-1616-3-T15 | ● | ● | 16 | 16 | 100 | 16.3 | 15 | | | | |
| ADKT-ZCC2-R/L-2020-3-T20 | ● | ● | 20 | 20 | 125 | 20.3 | 20 | ZT.D - 3 | 2004-M8x1x20 | - | AAL-05-4 |
| ADKT-ZCC2-R/L-2525-3-T22 | ● | ● | 25 | 25 | 150 | 25.3 | 22 | | | | |
| ADKT-ZCC2-R/L-2020-4-T20 | ● | ● | 20 | 20 | 125 | 20.5 | 20 | ZT.D - 4 | 2004-M8x1x20 | - | AAL-05-4 |
| ADKT-ZCC2-R/L-2525-4-T22 | ● | ● | 25 | 25 | 150 | 25.5 | 22 | | | | |
| ADKT-ZCC2-R/L-2020-5-T20 | ● | ● | 20 | 20 | 125 | 20.5 | 20 | ZT.D - 5 | 2004-M8x1x20 | - | AAL-05-4 |
| ADKT-ZCC2-R/L-2525-5-T25 | ● | ● | 25 | 25 | 150 | 25.5 | 25 | | | | |
| ADKT-ZCC2-R/L-2020-6-T20 | ● | ● | 20 | 20 | 125 | 20.6 | 20 | ZT.D - 6 | 2004-M8x1x20 | - | AAL-05-4 |
| ADKT-ZCC2-R/L-2525-6-T25 | ● | ● | 25 | 25 | 150 | 25.6 | 25 | | | | |
| ADKT-ZCC2-R/L-3232-6-T25 | ● | ● | 32 | 32 | 170 | 32.6 | 25 | ZT.D - 6 | 2004-M8x1x20 | - | AAL-05-4 |
| ADKT-ZCC2-R/L-3232-6-T30 | ● | ● | 32 | 32 | 170 | 32.6 | 30 | | | | |

R: Sağ/Right L: Sol/Left ● Stokta/In Stock ○ Stokta Yok/Non Stock Item
ZCC Ucuna Uygundur. / Compatible with ZCC Insert.

Sipariş Örneği/Ordering Example : 1 ad./pcs. ADKT-ZCC2-2020-2-T15

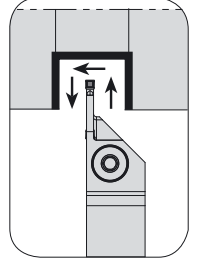
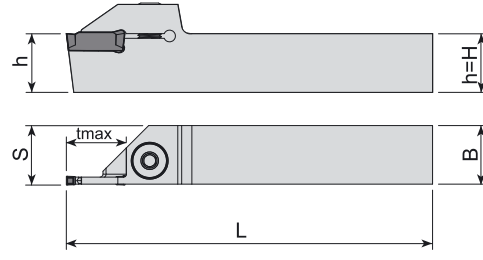

| Takım Kodu Ordering Code | Stok Stock | | Takım Ölçüleri (mm) Dimension (mm) | | | | Kesici Uç Insert | Yedek Parçaları Spare Parts | | | |
|-----------------------------|---------------|---|---------------------------------------|----|-----|------|---------------------|--------------------------------|-----------------------------|--------------|----------------------|
| | R | L | h=H | B | L | S | | t _{max} | Sıkma Vidası Clamp Screw | Pul Stamp | Anahtar Allen Key |
| ADKT-I-R/L-1212-2-T15 | ● | ● | 12 | 12 | 100 | 12.3 | 15 | DGN - 2 | AKV-02-M6x22 | ABPL-01 | AAL-03-3 |
| ADKT-I-R/L-1616-2-T15 | ● | ● | 16 | 16 | 100 | 16.3 | 15 | | | | |
| ADKT-I-R/L-2020-2-T15 | ● | ● | 20 | 20 | 125 | 20.3 | 15 | | | | |
| ADKT-I-R/L-2525-2-T15 | ● | ● | 25 | 25 | 150 | 25.3 | 15 | DGN - 3 | | | |
| ADKT-I-R/L-1212-3-T15 | ● | ● | 12 | 12 | 100 | 12.3 | 15 | | | | |
| ADKT-I-R/L-1616-3-T15 | ● | ● | 16 | 16 | 100 | 16.4 | 15 | | | | |
| ADKT-I-R/L-2020-3-T20 | ● | ● | 20 | 20 | 125 | 20.4 | 20 | DGN / GRP - 4 | 2004-M8x1x20 | - | AAL-05-4 |
| ADKT-I-R/L-2525-3-T22 | ● | ● | 25 | 25 | 150 | 25.4 | 22 | | | | |
| ADKT-I-R/L-2020-4-T20 | ● | ● | 20 | 20 | 125 | 20.4 | 20 | | | | |
| ADKT-I-R/L-2525-4-T22 | ● | ● | 25 | 25 | 150 | 25.4 | 22 | DGN / GRP - 5 | | | |
| ADKT-I-R/L-2020-5-T20 | ● | ● | 20 | 20 | 125 | 20.5 | 20 | | | | |
| ADKT-I-R/L-2525-5-T25 | ● | ● | 25 | 25 | 150 | 25.5 | 25 | | | | |
| ADKT-IG-R/L-2020-3-R20 | ● | ● | 20 | 20 | 125 | 20.4 | 20 | GRP - 3 | | | |
| ADKT-IG-R/L-2525-3-T22 | ● | ● | 25 | 25 | 150 | 25.4 | 22 | | | | |
| ADKT-IGI-R/L-2020-2-T15 | ● | ● | 20 | 20 | 125 | 20.3 | 15 | GIM / GIP - 2 | AKV-02-M6x22 | ABPL-01 | AAL-03-3 |
| ADKT-IGI-R/L-2525-2-T15 | ● | ● | 25 | 25 | 150 | 25.4 | 15 | | | | |
| ADKT-IGI-R/L-1616-3-T15 | ● | ● | 16 | 16 | 100 | 16.4 | 15 | | | | |
| ADKT-IGI-R/L-2020-3-T20 | ● | ● | 20 | 20 | 125 | 20.4 | 20 | GIM / GIP - 3 | 2004-M8x1x20 | - | AAL-05-4 |
| ADKT-IGI-R/L-2525-3-T22 | ● | ● | 25 | 25 | 150 | 25.4 | 22 | | | | |
| ADKT-IGI-R/L-2525-4-T22 | ● | ● | 25 | 25 | 150 | 25.5 | 22 | | | | |
| ADKT-IGI-R/L-2525-5-T25 | ● | ● | 25 | 25 | 150 | 25.6 | 25 | GIM / GIP - 5 | | | |
| ADKT-IGI-R/L-2525-8-T30 | ● | ● | 25 | 25 | 150 | 25.8 | 30 | GIM / GIP - 8 | | | |
| ADKT-IGTN-R/L-2525-5-T25 | ● | ● | 25 | 25 | 150 | 25.6 | 25 | GTN - 5 | | | |

R: Sağ/Right L: Sol/Left ● Stokta/In Stock ○ Stokta Yok/Non Stock Item
ISCR Ucuna Uygunudur. / Compatible With ISCR Insert

Sipariş Örneği/Ordering Example : 1 ad./pcs. ADKT-I-R-1212-2-T15

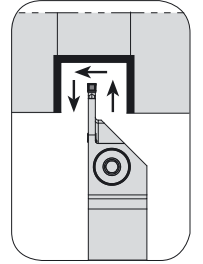
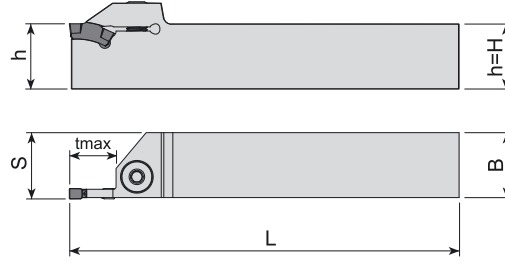

| Takım Kodu Ordering Code | Stok Stock | | Takım Ölçüleri (mm) Dimension (mm) | | | | | Kesici Uç Insert | Yedek Parçaları Spare Parts | | |
|-----------------------------|---------------|---|---------------------------------------|----|-----|------|-------|---------------------|--------------------------------|--------------|----------------------|
| | R | L | h=H | B | L | S | t max | | Sıkma Vidası Clamp Screw | Pul Stamp | Anahtar Allen Key |
| ADKT-ITG-R/L-2020-3-T8 | ● | ● | 20 | 20 | 125 | 20.3 | 8 | TGM. - 3 | 2004-M8x1x20 | - | AAL-05-4 |
| ADKT-ITG-R/L-2525-3-T8 | ● | ● | 25 | 25 | 150 | 25.3 | 8 | | | | |
| ADKT-ITG-R/L-3232-3-T8 | ● | ● | 32 | 32 | 170 | 32.3 | 8 | | | | |
| ADKT-ITG-R/L-2020-4-T9 | ● | ● | 20 | 20 | 125 | 20.4 | 9 | TGM. - 4 | 2004-M8x1x20 | - | AAL-05-4 |
| ADKT-ITG-R/L-2525-4-T17 | ● | ● | 25 | 25 | 150 | 25.4 | 17 | | | | |
| ADKT-ITG-R/L-3232-4-T17 | ● | ● | 32 | 32 | 170 | 32.4 | 17 | | | | |

ISCR Ucuna Uygundur. / Compatible with ISCR Insert.

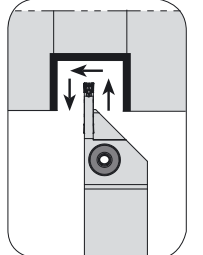
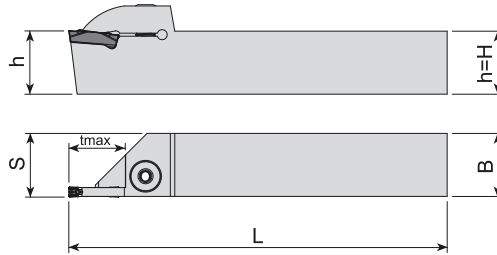

| Takım Kodu Ordering Code | Stok Stock | | Takım Ölçüleri (mm) Dimension (mm) | | | | | Kesici Uç Insert | Yedek Parçaları Spare Parts | | |
|-----------------------------|---------------|---|---------------------------------------|----|-----|------|-------|---------------------|--------------------------------|--------------|----------------------|
| | R | L | h=H | B | L | S | t max | | Sıkma Vidası Clamp Screw | Pul Stamp | Anahtar Allen Key |
| ADKT-KM-R/L-2020-2-T15 | ● | ● | 20 | 20 | 125 | 20.3 | 15 | A4. - 2 | AKV-02-M6x22 | ABPL-01 | AAL-03-3 |
| ADKT-KM-R/L-2525-2-T15 | ● | ● | 25 | 25 | 150 | 25.3 | 15 | | | | |
| ADKT-KM-R/L-2020-3-T20 | ● | ● | 20 | 20 | 125 | 20.4 | 20 | A4. - 3 | 2004-M8x1x20 | - | AAL-05-4 |
| ADKT-KM-R/L-2525-3-T22 | ● | ● | 25 | 25 | 150 | 25.4 | 22 | | | | |
| ADKT-KM-R/L-2525-4-T22 | ● | ● | 25 | 25 | 150 | 25.5 | 22 | | | | |

R: Sağ/Right L: Sol/Left ● Stokta/In Stock ○ Stokta Yok/Non Stock Item

KNMTL Ucuna Uygundur. / Compatible with KNMTL Insert.

Sipariş Örneği/Ordering Example : 1 ad./pcs. ADKT-ITG-R-2020-3-T8

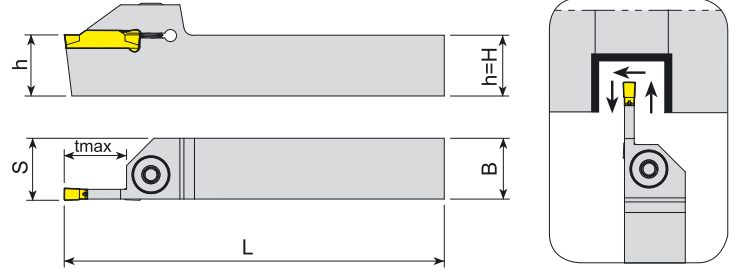

| Takım Kodu Ordering Code | Stok Stock | | Takım Ölçüleri (mm) Dimension (mm) | | | | | Kesici Uç Insert | Yedek Parçaları Spare Parts | | |
|-----------------------------|---------------|---|---------------------------------------|----|-----|------|----------|---------------------|--------------------------------|--------------|----------------------|
| | R | L | h=H | B | L | S | t max | | Sıkma Vidası Clamp Screw | Pul Stamp | Anahtar Allen Key |
| ADKT-123-R/L-1616-2-T15 | ● | ● | 16 | 16 | 100 | 16.3 | 15 | 123 - 2 | AKV-02-M6x22 | ABPL-01 | AAL-03-3 |
| ADKT-123-R/L-2020-2-T15 | ● | ● | 20 | 20 | 125 | 20.3 | 15 | | | | |
| ADKT-123-R/L-2525-2-T15 | ● | ● | 25 | 25 | 150 | 25.3 | 15 | | | | |
| ADKT-123-R/L-3232-2-T15 | ● | ● | 32 | 32 | 170 | 32.3 | 15 | | | | |
| ADKT-123-R/L-1616-3-T15 | ● | ● | 16 | 16 | 100 | 16.4 | 15 | 123 - 3 | 2004-M8x1x20 | - | AAL-05-4 |
| ADKT-123-R/L-2020-3-T20 | ● | ● | 20 | 20 | 125 | 20.4 | 20 | | | | |
| ADKT-123-R/L-2525-3-T22 | ● | ● | 25 | 25 | 150 | 25.4 | 22 | | | | |
| ADKT-123-R/L-2020-4-T20 | ● | ● | 20 | 20 | 125 | 20.4 | 20 | | | | |
| ADKT-123-R/L-2525-4-T22 | ● | ● | 25 | 25 | 150 | 25.4 | 22 | | | | |
| ADKT-123-R/L-3232-4-T25 | ● | ● | 32 | 32 | 170 | 32.4 | 25 | 123 - 4 | | | |
| ADKT-123-R/L-2020-5-T20 | ● | ● | 20 | 20 | 125 | 20.5 | 20 | 123 - 5 | | | |
| ADKT-123-R/L-2525-5-T25 | ● | ● | 25 | 25 | 150 | 25.5 | 25 | | | | |

R: Sağ/Right L: Sol/Left ● Stokta/In Stock ○ Stokta Yok/Non Stock Item
SNDVK Ucuna Uygundur. / Compatible with SNDVK Insert.

Sipariş Örneği/Ordering Example : 1 ad./pcs. ADKT-123-R-1616-2-T15



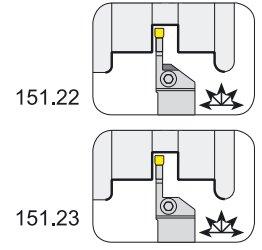
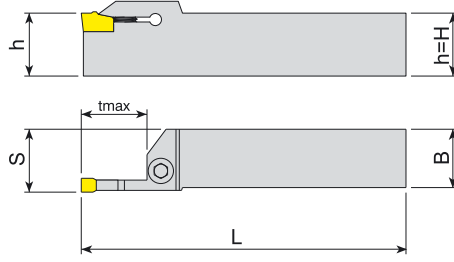

| Takım Kodu Ordering Code | Stok Stock | | Takım Ölçüleri (mm) Dimension (mm) | | | | | Kesici Uç Insert | Yedek Parçaları Spare Parts | | |
|------------------------------|---------------|---|---------------------------------------|----|-----|------|-------|---------------------|--------------------------------|--------------|----------------------|
| | R | L | h=H | B | L | S | t max | | Sıkma Vidası Clamp Screw | Pul Stamp | Anahtar Allen Key |
| ADKT-151.22-R/L-1616-2-T15 | ● | ● | 16 | 16 | 100 | 16.3 | 15 | 151.2 - 2 | AKV-02-M6x22 | ABPL-01 | AAL-03-3 |
| ADKT-151.22-R/L-2020-2-T15 | ● | ● | 20 | 20 | 125 | 20.3 | 15 | | | | |
| ADKT-151.22-R/L-2525-2-T15 | ● | ● | 25 | 25 | 150 | 25.3 | 15 | | | | |
| ADKT-151.22-R/L-1616-3-T15 | ● | ● | 16 | 16 | 100 | 16.4 | 15 | 151.2 - 3 | 2004-M8x1x20 | - | AAL-05-4 |
| ADKT-151.22-R/L-2020-3-T20 | ● | ● | 20 | 20 | 125 | 20.4 | 20 | | | | |
| ADKT-151.22-R/L-2525-3-T22 | ● | ● | 25 | 25 | 150 | 25.4 | 22 | | | | |
| ADKT-151.22-R/L-1616-4-T15 | ○ | ○ | 16 | 16 | 100 | 16.4 | 15 | 151.2 - 4 | 2004-M8x1x20 | - | AAL-05-4 |
| ADKT-151.22-R/L-2020-4-T20 | ● | ● | 20 | 20 | 125 | 20.4 | 20 | | | | |
| ADKT-151.22-R/L-2525-4-T22 | ● | ● | 25 | 25 | 150 | 25.4 | 22 | | | | |
| ADKT-151.22-R/L-2020-5-T20 | ● | ● | 20 | 20 | 125 | 20.5 | 20 | 151.2 - 5 | 2004-M8x1x20 | - | AAL-05-4 |
| ADKT-151.22-R/L-2525-5-T25 | ● | ● | 25 | 25 | 150 | 25.5 | 25 | | | | |
| ADKT-151.23-R/L-1616-2-T15 | ● | ○ | 16 | 16 | 100 | 16.3 | 15 | 151.2 - 2 | AKV-02-M6x22 | ABPL-01 | AAL-03-3 |
| ADKT-151.23-R/L-2020-2-T15 | ● | ● | 20 | 20 | 125 | 20.3 | 15 | | | | |
| ADKT-151.23-R/L-2525-2-T15 | ● | ○ | 25 | 25 | 150 | 25.3 | 15 | | | | |
| ADKT-151.23-R/L-1616-2.5-T15 | ○ | ○ | 16 | 16 | 100 | 16.3 | 15 | 151.2 - 2.5 | 2004-M8x1x20 | - | AAL-05-4 |
| ADKT-151.23-R/L-2020-2.5-T15 | ● | ○ | 20 | 20 | 125 | 20.3 | 15 | | | | |
| ADKT-151.23-R/L-2525-2.5-T15 | ● | ● | 25 | 25 | 150 | 25.3 | 15 | | | | |
| ADKT-151.23-R/L-1212-3-T15 | ● | ● | 12 | 12 | 100 | 12.4 | 15 | 151.2 - 3 | 2004-M8x1x20 | - | AAL-05-4 |
| ADKT-151.23-R/L-1616-3-T15 | ● | ● | 16 | 16 | 100 | 16.4 | 15 | | | | |
| ADKT-151.23-R/L-2020-3-T20 | ● | ● | 20 | 20 | 125 | 20.4 | 20 | | | | |
| ADKT-151.23-R/L-2525-3-T20 | ● | ● | 25 | 25 | 150 | 25.4 | 20 | 151.2 - 4 | 2004-M8x1x20 | - | AAL-05-4 |
| ADKT-151.23-R/L-2525-3-T22 | ● | ● | 25 | 25 | 150 | 25.4 | 22 | | | | |
| ADKT-151.23-R/L-1616-4-T15 | ● | ○ | 16 | 16 | 100 | 16.4 | 15 | | | | |
| ADKT-151.23-R/L-2020-4-T20 | ● | ● | 20 | 20 | 125 | 20.4 | 20 | 151.2 - 5 | 2004-M8x1x20 | - | AAL-05-4 |
| ADKT-151.23-R/L-2525-4-T22 | ● | ○ | 25 | 25 | 150 | 25.4 | 22 | | | | |
| ADKT-151.23-R/L-2020-5-T20 | ● | ● | 20 | 20 | 125 | 20.5 | 20 | 151.2 - 5 | 2004-M8x1x20 | - | AAL-05-4 |
| ADKT-151.23-R/L-2525-5-T25 | ● | ● | 25 | 25 | 150 | 25.5 | 25 | | | | |

R: Sağ/Right L: Sol/Left ● Stokta/In Stock ○ Stokta Yok/Non Stock Item
SNDVK Ucuna Uygundur. / Compatible with SNDVK Insert.

Sipariş Örneği/Ordering Example : 1 ad./pcs. ADKT-151.22-R-1616-2-T15

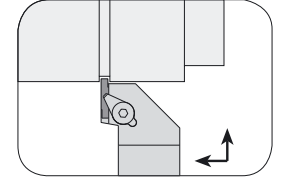
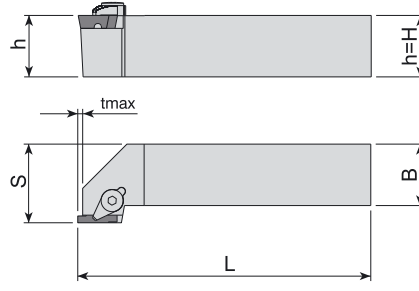

| Takım Kodu Ordering Code | Stok Stock | Takım Ölçüleri (mm) Dimension (mm) | | | | | | Kesici Uç Insert | Yedek Parçaları Spare Parts | | | |
|-----------------------------|---------------|---------------------------------------|----|-----|------|---|------------|---------------------|--------------------------------|------------------------------|-----------------------------|------------|
| | | R | L | h=H | B | L | S | | t max | Baskı Parçası Wedge Clamp | Sıkma Vidası Clamp Screw | Pim Pin |
| ADKT-154-91-R/L-2020-3-T4 | ●● | 20 | 20 | 125 | 20.4 | 4 | 154.91 - 3 | | ACK-03 | AKV-07-M6x22 | APM-06 | AAL-03-3 |
| ADKT-154-91-R/L 2525-3-T4 | ●● | 25 | 25 | 150 | 25.4 | 4 | | | | | | |
| ADKT-154-91-R/L 2020-5-T5 | ●● | 20 | 20 | 125 | 20.5 | 5 | 154.91 - 5 | | ACK-03 | AKV-07-M6x22 | APM-06 | AAL-03-3 |
| ADKT-154-91-R/L 2525-5-T5 | ●● | 25 | 25 | 150 | 25.5 | 5 | | | | | | |

SNDVK Ucuna Uygundur. / Compatible with SNDVK Insert.

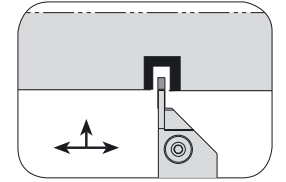
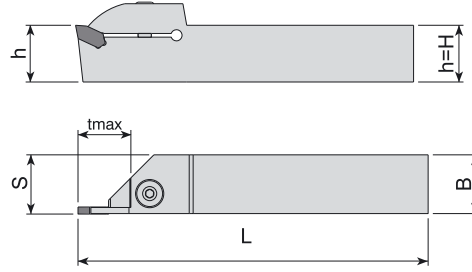

| Takım Kodu Ordering Code | Stok Stock | Takım Ölçüleri (mm) Dimension (mm) | | | | | | Kesici Uç Insert | Yedek Parçaları Spare Parts | | |
|-----------------------------|---------------|---------------------------------------|----|-----|------|----|-----------|---------------------|--------------------------------|-----------------------------|--------------|
| | | R | L | h=H | B | L | S | | t max | Sıkma Vidası Clamp Screw | Pul Stamp |
| ADKT-ARN-R/L-2020-2-T15 | ●● | 20 | 20 | 125 | 20.3 | 15 | LOMR. - 2 | | AKV-02-M6x22 | ABPL-01 | AAL-03-3 |
| ADKT-ARN-R/L-2525-2-T15 | ●● | 25 | 25 | 150 | 25.3 | 15 | | | | | |
| ADKT-ARN-R/L-2020-3-T20 | ●● | 20 | 20 | 125 | 20.4 | 20 | LOMR. - 3 | | 2004-M8x1x20 | - | AAL-05-4 |
| ADKT-ARN-R/L-2525-3-T22 | ●● | 25 | 25 | 150 | 25.4 | 22 | | | | | |

R: Sağ/Right L: Sol/Left ● Stokta/In Stock ○ Stokta Yok/Non Stock Item
ARN Ucuna Uygundur. / Compatible with ARN Insert.

Sipariş Örneği/Ordering Example : 1 ad./pcs. ADKT-154.91-R-2020-3-T4

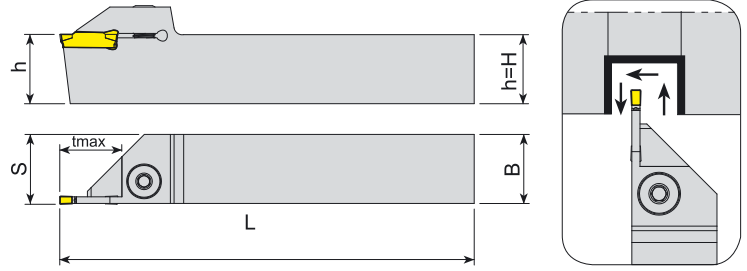

| Takım Kodu Ordering Code | Stok Stock | | Takım Ölçüleri (mm) Dimension (mm) | | | | | Kesici Uç Insert | Yedek Parçaları Spare Parts | | |
|-----------------------------|---------------|---|---------------------------------------|----|-----|------|-------|---------------------|--------------------------------|--------------|----------------------|
| | R | L | h=H | B | L | S | t max | | Sıkma Vidası Clamp Screw | Pul Stamp | Anahtar Allen Key |
| ADKT-TD-R/L-1212-2-T15 | ● | ● | 12 | 12 | 100 | 12.3 | 15 | TD. - 2 | AKV-02-M6x22 | ABPL-01 | AAL-03-3 |
| ADKT-TD-R/L-1616-2-T15 | ● | ● | 16 | 16 | 100 | 16.3 | 15 | | | | |
| ADKT-TD-R/L-2020-2-T15 | ● | ○ | 20 | 20 | 125 | 20.3 | 15 | | | | |
| ADKT-TD-R/L-2525-2-T17 | ● | ○ | 25 | 25 | 150 | 25.3 | 17 | | | | |
| ADKT-TD-R/L-1212-3-T15 | ● | ○ | 12 | 12 | 100 | 12.3 | 15 | TD. - 3 | 2004-M8x1x20 | - | AAL-05-4 |
| ADKT-TD-R/L-1616-3-T15 | ● | ● | 16 | 16 | 100 | 16.4 | 15 | | | | |
| ADKT-TD-R/L-2020-3-T20 | ● | ● | 20 | 20 | 125 | 20.4 | 20 | | | | |
| ADKT-TD-R/L-2525-3-T9 | ● | ● | 25 | 25 | 150 | 25.4 | 9 | | | | |
| ADKT-TD-R/L-2525-3-T22 | ○ | ○ | 25 | 25 | 150 | 25.4 | 22 | | | | |

TGTC Ucuna Uygun. / Compatible With TGTC Insert.

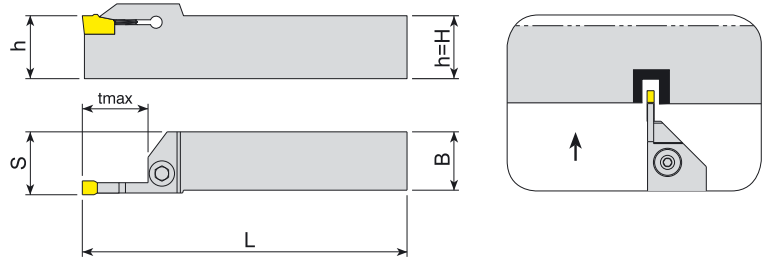

| Takım Kodu Ordering Code | Stok Stock | | Takım Ölçüleri (mm) Dimension (mm) | | | | | Kesici Uç Insert | Yedek Parçaları Spare Parts | | |
|-----------------------------|---------------|---|---------------------------------------|----|-----|------|-------|---------------------|--------------------------------|--------------|----------------------|
| | R | L | h=H | B | L | S | t max | | Sıkma Vidası Clamp Screw | Pul Stamp | Anahtar Allen Key |
| ADKT-SWC-R/L-2020-2-T25 | ● | ○ | 20 | 20 | 125 | 20.3 | 25 | WCF. - 2 | AKV-02-M6x22 | ABPL-01 | AAL-03-3 |
| ADKT-SWC-R/L-2020-3-T25 | ● | ○ | 20 | 20 | 125 | 20.4 | 25 | WCF. - 3 | 2004-M8x1x20 | - | AAL-05-4 |

R: Sağ/Right L: Sol/Left ● Stokta/In Stock ○ Stokta Yok/Non Stock Item
SMTM Ucuna Uygun. / Compatible with SMTM Insert.

Sipariş Örneği/Ordering Example : 1 ad./pcs. ADKT-TD-R-1212-2-T15

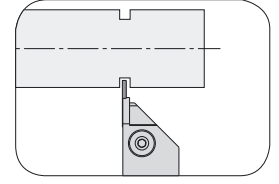
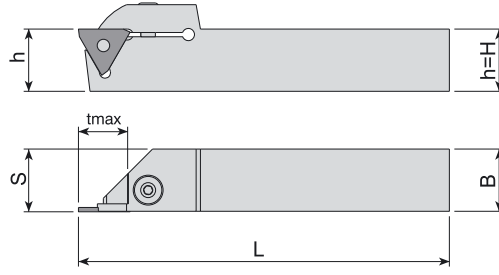

| Takım Kodu Ordering Code | Stok Stock | | Takım Ölçüleri (mm) Dimension (mm) | | | | | Kesici Uç Insert | Yedek Parçaları Spare Parts | | |
|------------------------------|---------------|---|---------------------------------------|----|-----|------|----------|---------------------|--------------------------------|--------------|----------------------|
| | R | L | h=H | B | L | S | t max | | Sıkma Vidası Clamp Screw | Pul Stamp | Anahtar Allen Key |
| ADKT-H22-R/L-1616-(0.5-2)-T6 | ● | ● | 16 | 16 | 100 | 16.2 | 6 | S312 - (0.5-2) | | | AAL-05-4 |
| ADKT-H22-R/L-2020-(0.5-2)-T6 | ● | ● | 20 | 20 | 125 | 20.2 | 6 | | | | |
| ADKT-H22-R/L-2525-(0.5-2)-T6 | ● | ● | 25 | 25 | 150 | 25.2 | 6 | | | | |

HRN Ucuna Uygun. / Compatible with HRN Insert.

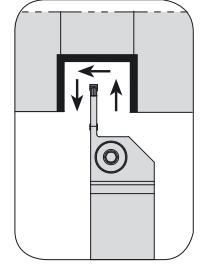
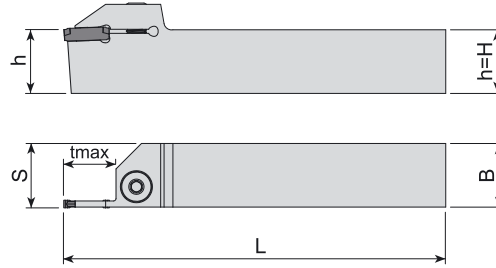

| Takım Kodu Ordering Code | Stok Stock | | Takım Ölçüleri (mm) Dimension (mm) | | | | | Kesici Uç Insert | Yedek Parçaları Spare Parts | | |
|-----------------------------|---------------|---|---------------------------------------|----|-----|------|----------|---------------------|--------------------------------|--------------|----------------------|
| | R | L | h=H | B | L | S | t max | | Sıkma Vidası Clamp Screw | Pul Stamp | Anahtar Allen Key |
| ADKT-LGC-R/L-1616-2-D40 | ● | ● | 16 | 16 | 125 | 16.2 | 20 | GCTX - 2 | AKV-02-M6x22 | ABPL-01 | AAL-03-3 |
| ADKT-LGC-R/L-2020-2-D40 | ● | ● | 20 | 20 | 125 | 20.2 | 20 | | | | |
| ADKT-LGC-R/L-2525-2-D40 | ● | ● | 25 | 25 | 150 | 25.2 | 20 | | | | |
| ADKT-LGC-R/L-1616-3-T20 | ● | ● | 16 | 16 | 125 | 16.3 | 20 | GCTX - 3 | 2004-M8x1x20 | - | AAL-05-4 |
| ADKT-LGC-R/L-2020-3-T20 | ● | ● | 20 | 20 | 125 | 20.3 | 20 | | | | |
| ADKT-LGC-R/L-2525-3-T20 | ● | ● | 25 | 25 | 150 | 25.3 | 20 | | | | |

R: Sağ/Right L: Sol/Left ● Stokta/In Stock ○ Stokta Yok/Non Stock Item
LMN Ucuna Uygun. / Compatible with LMN Insert.

Sipariş Örneği/Ordering Example : 1 ad./pcs. ADKT-H22-R-1616-(0.5-2)T16

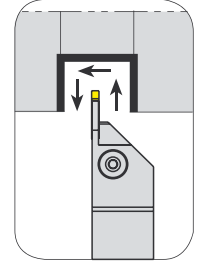
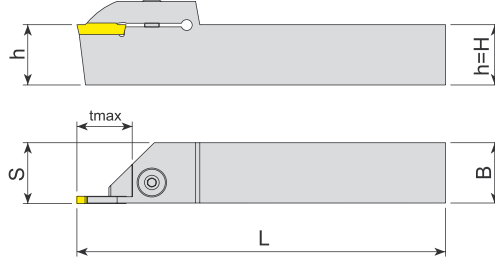

| Takım Kodu Ordering Code | Stok Stock | | Takım Ölçüleri (mm) Dimension (mm) | | | | | Kesici Uç Insert | Yedek Parçaları Spare Parts | | |
|-----------------------------|---------------|---|---------------------------------------|----|-----|------|-------|---------------------|--------------------------------|--------------|----------------------|
| | R | L | h=H | B | L | S | t max | | Sıkma Vidası Clamp Screw | Pul Stamp | Anahtar Allen Key |
| ADKT-WGX24-R/L-2525-4-T22 | ● | ● | 25 | 25 | 150 | 25.4 | 22 | GX24. - 4 | 2004-M8x1x20 | - | AAL-05-4 |
| ADKT-WGX24-R/L-2525-5-T25 | ● | ● | 25 | 25 | 150 | 25.5 | 25 | | | | |

WLTR Ucuna Uygun. / Compatible with WLTR Insert.

DIŞ ÇAP KANAL AÇMA İSVEÇ TİPİ KAYAR OTOMAT MAKİNA TAKIMLARI
EXTERNAL GROOVING TOOLHOLDERS FOR SWISS TYPE SLIDING AUTOMATIC LATHES

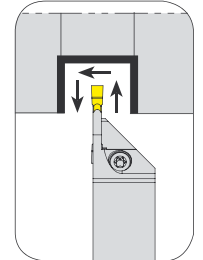
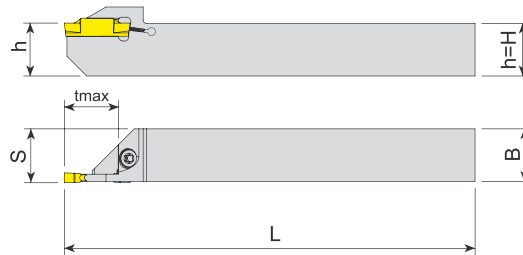

| Takım Kodu Ordering Code | Stok Stock | | Takım Ölçüleri (mm) Dimension (mm) | | | | | Kesici Uç Insert | Yedek Parçaları Spare Parts | | |
|-----------------------------|---------------|---|---------------------------------------|----|-----|------|-------|---------------------|--------------------------------|--------------|--------------------------|
| | R | L | h=H | B | L | S | t max | | Sıkma Vidası Clamp Screw | Pul Stamp | Tork Anahtar Torx Key |
| ADKT-TD-R/L-1212-2-T12-K-S | ● | ● | 12 | 12 | 125 | 12.2 | 12 | TD. - 2 | 1515-M4x11 | - | 80-T15 |
| ADKT-TD-R/L-1616-2-T16-K-S | ● | ● | 16 | 16 | 125 | 16.2 | 16 | | | | |
| ADKT-TD-R/L-1212-3-T12-K-S | ● | ● | 12 | 12 | 125 | 12.3 | 12 | TD. - 3 | - | - | - |
| ADKT-TD-R/L-1616-3-T16-K-S | ● | ● | 16 | 16 | 125 | 16.3 | 16 | | | | |

R: Sağ/Right L: Sol/Left ● Stokta/In Stock ○ Stokta Yok/Non Stock Item
TGTC Ucuna Uygun. / Compatible with TGTC Insert.

Sipariş Örneği/Ordering Example : 1 ad./pcs. ADKT-WGX24-R-2525-4-T22

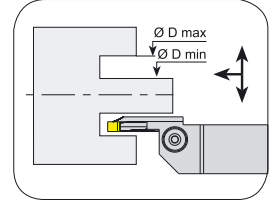
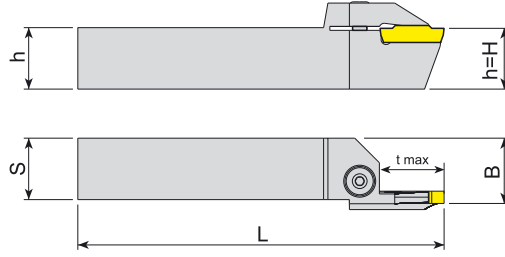

| Takım Kodu Ordering Code | Stok Stock | | Takım Ölçüleri (mm) Dimension (mm) | | | | | | | Kesici Uç Insert | Yedek Parçaları Spare Parts | | |
|-------------------------------|---------------|---|---------------------------------------|----|-----|------|-------|---------|---------|---------------------|--------------------------------|--------------|----------------------|
| | R | L | h=H | B | L | S | t max | Ø D min | Ø D max | | Sıkma Vidası Clamp Screw | Pul Stamp | Anahtar Allen Key |
| AAKT-K-R/L-2525-34-45-3-T17 | ● | ● | 25 | 25 | 150 | 26.5 | 17 | 34 | 45 | MGM. - 3 | | | |
| AAKT-K-R/L-2525-39-55-3-T17 | ● | ● | 25 | 25 | 150 | 26.5 | 17 | 39 | 55 | | | | |
| AAKT-K-R/L-2525-49-80-3-T17 | ● | ● | 25 | 25 | 150 | 26.5 | 17 | 49 | 80 | | | | |
| AAKT-K-R/L-2525-70-110-3-T17 | ● | ● | 25 | 25 | 150 | 26.5 | 17 | 70 | 110 | | | | |
| AAKT-K-R/L-2525-100-150-3-T17 | ● | ● | 25 | 25 | 150 | 26.5 | 17 | 100 | 150 | | | | |
| AAKT-K-R/L-2525-80-180-3-T32 | ● | ○ | 25 | 25 | 150 | 26.5 | 32 | 80 | 180 | MGM. - 4 | 2004-M8x1x20 | - | AAL-05-4 |
| AAKT-K-R/L-2525-50-85-4-T22 | ● | ● | 25 | 25 | 150 | 26.5 | 22 | 50 | 85 | | | | |
| AAKT-K-R/L-2525-70-110-4-T22 | ● | ● | 25 | 25 | 150 | 26.5 | 22 | 70 | 110 | | | | |
| AAKT-K-R/L-2525-100-150-4-T22 | ● | ● | 25 | 25 | 150 | 26.5 | 22 | 100 | 150 | | | | |
| AAKT-K-R/L-2525-80-180-4-T32 | ● | ○ | 25 | 25 | 150 | 26.5 | 32 | 80 | 180 | | | | |
| AAKT-K-R/L-2525-180-800-4-T32 | ● | ○ | 25 | 25 | 150 | 26.5 | 32 | 180 | 800 | MGM. - 5 | | | |
| AAKT-K-R/L-2525-70-110-5-T25 | ● | ● | 25 | 25 | 150 | 26.5 | 25 | 70 | 110 | | | | |
| AAKT-K-R/L-2525-100-150-5-T25 | ● | ● | 25 | 25 | 150 | 26.5 | 25 | 100 | 150 | | | | |
| AAKT-K-R/L-2525-80-180-5-T32 | ● | ○ | 25 | 25 | 150 | 26.5 | 32 | 80 | 180 | | | | |
| AAKT-K-R/L-2525-140-200-5-T25 | ● | ● | 25 | 25 | 150 | 26.5 | 25 | 140 | 200 | | | | |
| AAKT-K-R/L-2525-180-800-5-T32 | ● | ○ | 25 | 25 | 150 | 26.5 | 32 | 180 | 800 | MGM. - 6 | | | |
| AAKT-K-R/L-2525-140-300-6-T35 | ● | ○ | 25 | 25 | 150 | 26.5 | 35 | 140 | 300 | | | | |
| AAKT-K-R/L-2525-140-300-8-T35 | ● | ○ | 25 | 25 | 150 | 26.5 | 35 | 140 | 300 | MGM. - 8 | | | |
| AAKT-K-R/L-3232-140-350-8-T35 | ● | ○ | 32 | 32 | 150 | 32.5 | 35 | 140 | 350 | | | | |

R: Sağ/Right L: Sol/Left ● Stokta/In Stock ○ Stokta Yok/Non Stock Item
KRLY Ucuna Uygundur. / Compatible with KRLY Insert.

Sipariş Örneği/Ordering Example : 1 ad./pcs. AAKT-K-R-2525-34-45-3-T17

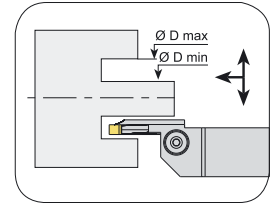
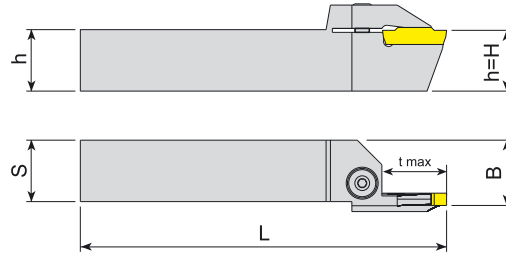

| Takım Kodu Ordering Code | Stok Stock | | Takım Ölçüleri (mm) Dimension (mm) | | | | | | | Kesici Uç Insert | Yedek Parçaları Spare Parts | | |
|--------------------------------|---------------|---|---------------------------------------|----|-----|------|----------|------------|------------|---------------------|--------------------------------|--------------|----------------------|
| | R | L | h=H | B | L | S | t max | Ø D min | Ø D max | | Sıkma Vidası Clamp Screw | Pul Stamp | Anahtar Allen Key |
| AAKT-KG-R/L-2525-44-70-4-T22 | ○ | ○ | 25 | 25 | 150 | 26.5 | 22 | 44 | 70 | KG.. - 4 | 2004-M8x1x20 | - | AAL-05-4 |
| AAKT-KG-R/L-2525-60-120-4-T22 | ○ | ○ | 25 | 25 | 150 | 26.5 | 22 | 60 | 120 | | | | |
| AAKT-KG-R/L-2525-112-200-4-T22 | ○ | ○ | 25 | 25 | 150 | 26.5 | 22 | 112 | 200 | | | | |

KRLY Ucuna Uygunur. / Compatible with KRLY Insert.

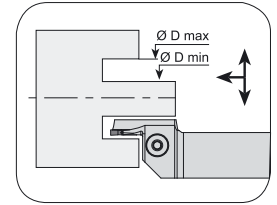
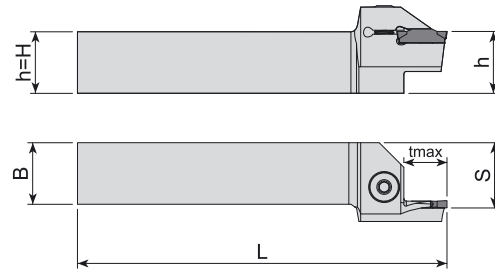

| Takım Kodu Ordering Code | Stok Stock | | Takım Ölçüleri (mm) Dimension (mm) | | | | | | | Kesici Uç Insert | Yedek Parçaları Spare Parts | | |
|----------------------------------|---------------|---|---------------------------------------|----|-----|------|----------|------------|------------|---------------------|--------------------------------|--------------|----------------------|
| | R | L | h=H | B | L | S | t max | Ø D min | Ø D max | | Sıkma Vidası Clamp Screw | Pul Stamp | Anahtar Allen Key |
| AAKT-ZCC2-R/L-2525-35-45-3-T17 | ● | ○ | 25 | 25 | 150 | 26.5 | 17 | 35 | 45 | ZT.D - 3 | 2004-M8x1x20 | - | AAL-05-4 |
| AAKT-ZCC2-R/L-2525-39-55-3-T17 | ● | ○ | 25 | 25 | 150 | 26.5 | 17 | 39 | 55 | | | | |
| AAKT-ZCC2-R/L-2525-49-80-3-T17 | ● | ○ | 25 | 25 | 150 | 26.5 | 17 | 49 | 80 | | | | |
| AAKT-ZCC2-R/L-2525-70-110-3-T17 | ● | ○ | 25 | 25 | 150 | 26.5 | 17 | 70 | 110 | | | | |
| AAKT-ZCC2-R/L-2525-100-150-3-T17 | ● | ○ | 25 | 25 | 150 | 26.5 | 17 | 100 | 150 | | | | |
| AAKT-ZCC2-R/L-2525-40-60-4-T22 | ● | ○ | 25 | 25 | 150 | 26.5 | 22 | 40 | 60 | ZT.D - 4 | 2004-M8x1x20 | - | AAL-05-4 |
| AAKT-ZCC2-R/L-2525-52-80-4-T22 | ● | ○ | 25 | 25 | 150 | 26.5 | 22 | 52 | 80 | | | | |
| AAKT-ZCC2-R/L-2525-72-110-4-T22 | ● | ○ | 25 | 25 | 150 | 26.5 | 22 | 72 | 110 | | | | |
| AAKT-ZCC2-R/L-2525-100-150-4-T22 | ● | ○ | 25 | 25 | 150 | 26.5 | 22 | 100 | 150 | | | | |
| AAKT-ZCC2-R/L-2525-140-200-4-T22 | ● | ○ | 25 | 25 | 150 | 26.5 | 22 | 140 | 200 | ZT.D - 5 | 2004-M8x1x20 | - | AAL-05-4 |
| AAKT-ZCC2-R/L-2525-55-95-5-T25 | ● | ○ | 25 | 25 | 150 | 26.5 | 25 | 55 | 95 | | | | |
| AAKT-ZCC2-R/L-2525-85-140-5-T25 | ● | ○ | 25 | 25 | 150 | 26.5 | 25 | 85 | 140 | | | | |
| AAKT-ZCC2-R/L-2525-130-200-5-T25 | ● | ○ | 25 | 25 | 150 | 26.5 | 25 | 130 | 200 | ZT.D - 5 | 2004-M8x1x20 | - | AAL-05-4 |
| AAKT-ZCC2-R/L-2525-190-400-5-T25 | ● | ○ | 25 | 25 | 150 | 26.5 | 25 | 190 | 400 | | | | |

R: Sağ/Right L: Sol/Left ● Stokta/In Stock ○ Stokta Yok/Non Stock Item
ZCC Ucuna Uygunur. / Compatible with ZCC Insert.

Sipariş Örneği/Ordering Example : 1 ad./pcs. ADKT-ZCC2-R-2525-35-45-3-T17

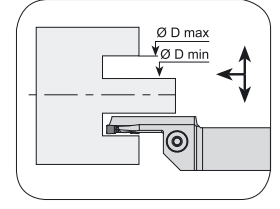
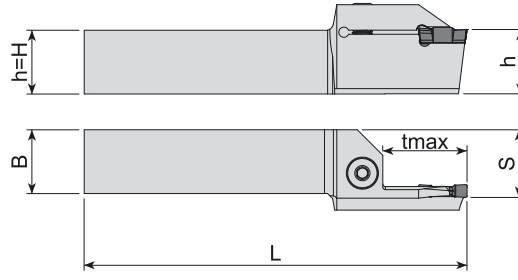

| Takım Kodu Ordering Code | Stok Stock | | Takım Ölçüleri (mm) Dimension (mm) | | | | | | Kesici Uç Insert | Yedek Parçaları Spare Parts | | | |
|--------------------------------|---------------|---|---------------------------------------|----|-----|------|----------|------------|---------------------|--------------------------------|-----------------------------|--------------|----------------------|
| | R | L | h=H | B | L | S | t max | Ø D min | | Ø D max | Sıkma Vidası Clamp Screw | Pul Stamp | Anahtar Allen Key |
| AAKT-IG-R/L-2525-40-60-4-T25 | ○ | ○ | 25 | 25 | 150 | 26.5 | 25 | 40 | 60 | DGN / GRP - 4 | 2004-M8x1x20 | - | AAL-05-4 |
| AAKT-IG-R/L-2525-52-80-4-T25 | ○ | ○ | 25 | 25 | 150 | 26.5 | 25 | 52 | 80 | | | | |
| AAKT-IG-R/L-2525-70-110-4-T28 | ● | ○ | 25 | 25 | 150 | 26.5 | 28 | 70 | 110 | | | | |
| AAKT-IG-R/L-2525-72-110-4-T25 | ○ | ○ | 25 | 25 | 150 | 26.5 | 25 | 72 | 110 | | | | |
| AAKT-IG-R/L-2525-100-150-4-T25 | ○ | ○ | 25 | 25 | 150 | 26.5 | 25 | 100 | 150 | | | | |
| AAKT-IG-R/L-2525-110-200-4-T28 | ● | ○ | 25 | 25 | 150 | 26.5 | 28 | 110 | 200 | | | | |
| AAKT-IG-R/L-2525-110-200-4-T32 | ● | ○ | 25 | 25 | 150 | 26.5 | 32 | 110 | 200 | | | | |
| AAKT-IG-R/L-2525-140-200-4-T25 | ○ | ○ | 25 | 25 | 150 | 26.5 | 25 | 140 | 200 | | | | |
| AAKT-IG-R/L-2525-180-800-4-T28 | ● | ○ | 25 | 25 | 150 | 26.5 | 28 | 180 | 800 | | | | |
| AAKT-IG-R/L-2525-200-800-4-T25 | ○ | ○ | 25 | 25 | 150 | 26.5 | 25 | 200 | 800 | | | | |
| AAKT-IG-R/L-2525-70-110-5-T32 | ● | ○ | 25 | 25 | 150 | 26.5 | 32 | 70 | 110 | DGN / GRP - 5 | | | |
| AAKT-IG-R/L-2525-110-200-5-T32 | ● | ● | 25 | 25 | 150 | 26.5 | 32 | 110 | 200 | | | | |
| AAKT-IG-R/L-2525-180-800-5-T32 | ● | ○ | 25 | 25 | 150 | 26.5 | 32 | 180 | 800 | | | | |
| AAKT-IG-R/L-2525-58-100-6-T32 | ● | ○ | 25 | 25 | 150 | 26.5 | 32 | 58 | 100 | DGN / GRP - 6 | | | |
| AAKT-IG-R/L-2525-88-180-6-T32 | ● | ○ | 25 | 25 | 150 | 26.5 | 32 | 88 | 180 | | | | |

R: Sağ/Right L: Sol/Left ● Stokta/In Stock ○ Stokta Yok/Non Stock Item
ISCR Ucuna Uygundur. / Compatiple with ISCR Insert.

Sipariş Örneği/Ordering Example : 1 ad./pcs. AAKT-IG-R-2525-40-60-4-T25



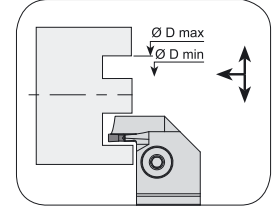
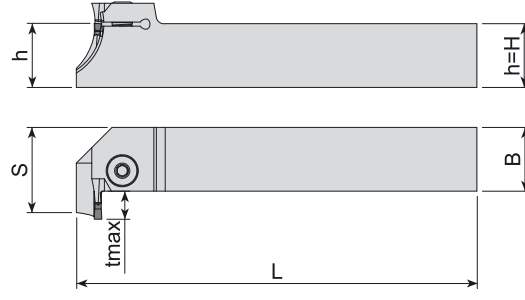

| Takım Kodu Ordering Code | Stok Stock | | Takım Ölçüleri (mm) Dimension (mm) | | | | | | Kesici Uç Insert | Yedek Parçaları Spare Parts | | | |
|----------------------------------|---------------|---|---------------------------------------|----|-----|----|-------|---------|---------------------|--------------------------------|-----------------------------|--------------|----------------------|
| | R | L | h=H | B | L | S | t max | Ø D min | | Ø D max | Sıkma Vidası Clamp Screw | Pul Stamp | Anahtar Allen Key |
| ALKT-ZCC2-R/L-2525-35-45-3-T10 | ● | ○ | 25 | 25 | 150 | 36 | 10 | 35 | 45 | ZTD - 3 | 2004-M8x1x20 | - | AAL-05-4 |
| ALKT-ZCC2-R/L-2525-39-55-3-T10 | ● | ○ | 25 | 25 | 150 | 36 | 10 | 39 | 55 | | | | |
| ALKT-ZCC2-R/L-2525-35-∞-3-T4 | ● | ○ | 25 | 25 | 150 | 30 | 4 | 35 | ∞ | ZTD - 4 | 2004-M8x1x20 | - | AAL-05-4 |
| ALKT-ZCC2-R/L-2525-40-60-4-T14 | ● | ○ | 25 | 25 | 150 | 40 | 14 | 40 | 60 | | | | |
| ALKT-ZCC2-R/L-2525-52-80-4-T14 | ● | ○ | 25 | 25 | 150 | 40 | 14 | 52 | 80 | ZTD - 4 | 2004-M8x1x20 | - | AAL-05-4 |
| ALKT-ZCC2-R/L-2525-72-110-4-T14 | ● | ○ | 25 | 25 | 150 | 40 | 14 | 72 | 110 | | | | |
| ALKT-ZCC2-R/L-2525-100-230-4-T14 | ● | ○ | 25 | 25 | 150 | 40 | 14 | 100 | 230 | ZTD - 4 | 2004-M8x1x20 | - | AAL-05-4 |
| ALKT-ZCC2-R/L-2525-40-∞-4-T4 | ● | ○ | 25 | 25 | 150 | 30 | 4 | 40 | ∞ | | | | |

R: Sağ/Right L: Sol/Left ● Stokta/In Stock ○ Stokta Yok/Non Stock Item
ZCC Ucuna Uygunudur. / Compatible with ZCC Insert.

Sipariş Örneği/Ordering Example : 1 ad./pcs. ALKT-ZCC2-R-2525-35-45-3-T10



➤ **KESME VE DERİN KANAL AÇMA LAMALARI**
BLADES FOR PARTING AND DEEP GROOVING

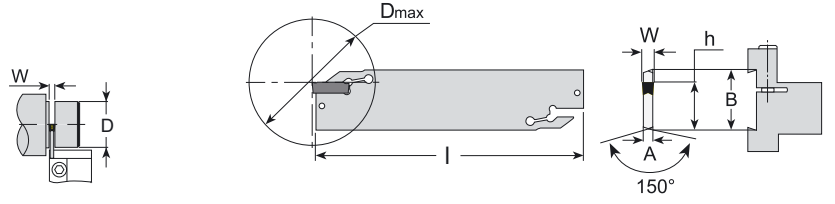

| Takım Kodu Ordering Code | Stok Stock | Takım Ölçüleri (mm) Dimension (mm) | | | | | | Kesici Uç Insert | Yedek Parçaları Spare Parts | |
|-----------------------------|---------------|---------------------------------------|---------|-----|-----|------|----------|---------------------|--------------------------------|--|
| | | B | W | A | I | h | D max | | Anahtar Key | |
| AKL-I-26-2 | ○ | 26 | 1.9-2.5 | 1.6 | 110 | 21.4 | 39 | | | |
| AKL-I-32-2 | ○ | 32 | 1.9-2.5 | 1.8 | 150 | 24.8 | 39 | | | |
| AKL-I-26-3 | ○ | 26 | 3-3.18 | 2.4 | 110 | 21.4 | 39 | | ABK-01 | |
| AKL-I-32-3 | ○ | 32 | 3-3.18 | 2.4 | 150 | 24.8 | 39 | | | |
| AKL-I-26-4 | ○ | 26 | 4 | 3.2 | 110 | 21.4 | 80 | | | |
| AKL-I-32-4 | ○ | 32 | 4 | 3.2 | 150 | 24.8 | 100 | | | |

ISCR Ucuna Uygundur. / Compatible with ISCR Insert.

➤ **KESME VE DERİN KANAL AÇMA LAMA BLOĞU**
BLOCKS FOR PARTING AND DEEP GROOVING BLADES

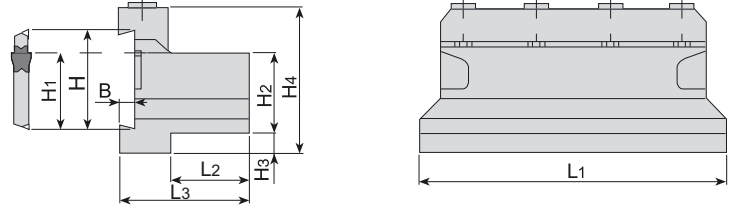

| Takım Kodu Ordering Code | Stok Stock | Takım Ölçüleri (mm) Dimension (mm) | | | | | | | | | Yedek Parçaları Spare Parts | |
|-----------------------------|---------------|---------------------------------------|------|----|----|----|-----|-----|----|----|--------------------------------|----------------------|
| | | H | H1 | H2 | H3 | H4 | B | L1 | L2 | L3 | Vida Screw | Anahtar Allen Key |
| ALBU-20-26 | ○ | 26 | 21.4 | 20 | 8 | 38 | 4 | 87 | 19 | 33 | | |
| ALBU-25-26 | ○ | 26 | 21.4 | 25 | 3 | 38 | 4 | 110 | 20 | 34 | | |
| ALBU-20-32 | ○ | 32 | 24.8 | 20 | 13 | 48 | 5.5 | 100 | 19 | 35 | | AAL-07-5 |
| ALBU-25-32 | ○ | 32 | 24.8 | 25 | 8 | 48 | 5.5 | 110 | 20 | 36 | | |
| ALBU-32-32 | ○ | 32 | 24.8 | 32 | 3 | 48 | 5.5 | 120 | 28 | 44 | | |

R: Sağ/Right L: Sol/Left ● Stokta/In Stock ○ Stokta Yok/Non Stock Item

Sipariş Örneği/Ordering Example : 1 ad./pcs. ALBU-20-26

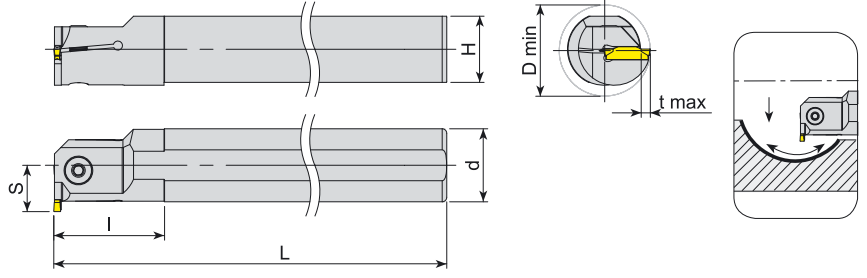

| Takım Kodu Ordering Code | Stok Stock | | Takım Ölçüleri (mm) Dimension (mm) | | | | | | | Kesici Uç Insert | Yedek Parçaları Spare Parts | |
|-----------------------------|---------------|---|---------------------------------------|----|-----|----|----------|------|------|---------------------|--------------------------------|----------------------|
| | R | L | d | D | L | I | t max | H | S | | Sıkma Vidası Clamp Screw | Anahtar Allen Key |
| AIKT-K-R/L-16-2-T4 | ● | ● | 16 | 20 | 150 | 33 | 4 | 14.8 | 11.5 | MGM. - 2 | 2503-M4x10 | AAL-03-3 |
| AIKT-K-R/L-20-2-T4 | ● | ● | 20 | 25 | 170 | 33 | 4 | 18.3 | 14.5 | | 2503-M4x12 | |
| AIKT-K-R/L-20-3-T6 | ● | ● | 20 | 25 | 170 | 33 | 6 | 18.3 | 15 | MGM. - 3 | 2504-M5x12 | AAL-05-4 |
| AIKT-K-R/L-20-3-T7 | ● | ○ | 20 | 25 | 170 | 33 | 7 | 18.3 | 16 | | 2504-M5x16 | |
| AIKT-K-R/L-25-3-T6 | ● | ● | 25 | 31 | 200 | 45 | 6 | 23 | 18.5 | | 2504-M5x16 | |
| AIKT-K-R/L-25-3-T10 | ● | ○ | 25 | 31 | 200 | 45 | 10 | 23 | 22.5 | | 2004-M8x1x20 | |
| AIKT-K-R/L-32-3-T6 | ● | ● | 32 | 37 | 250 | 49 | 6 | 30 | 22 | | 2004-M8x1x20 | |
| AIKT-K-R/L-32-3-T12 | ● | ○ | 32 | 37 | 250 | 49 | 12 | 30 | 28 | | 2004-M8x1x20 | |
| AIKT-K-R/L-40-3-T6 | ● | ● | 40 | 45 | 300 | 54 | 6 | 37.5 | 27 | | 2004-M8x1x20 | |
| AIKT-K-R/L-40-3-T12 | ● | ○ | 40 | 45 | 300 | 54 | 12 | 37.5 | 33 | | 2004-M8x1x20 | |
| AIKT-K-R/L-20-4-T6 | ● | ● | 20 | 25 | 170 | 34 | 6 | 18.3 | 14 | | 2504-M5x12 | |
| AIKT-K-R/L-20-4-T7 | ● | ○ | 20 | 25 | 170 | 34 | 7 | 18.3 | 15 | | 2504-M5x12 | |
| AIKT-K-R/L-25-4-T6 | ● | ● | 25 | 31 | 200 | 43 | 6 | 23 | 18.5 | 2504-M5x16 | | |
| AIKT-K-R/L-25-4-T10 | ● | ○ | 25 | 31 | 200 | 43 | 10 | 23 | 22.5 | 2504-M5x16 | | |
| AIKT-K-R/L-32-4-T6 | ● | ● | 32 | 37 | 250 | 43 | 6 | 30 | 22 | 2004-M8x1x20 | | |
| AIKT-K-R/L-32-4-T12 | ● | ○ | 32 | 37 | 250 | 43 | 12 | 30 | 28 | 2004-M8x1x20 | | |
| AIKT-K-R/L-40-4-T6 | ● | ● | 40 | 45 | 300 | 54 | 6 | 37.5 | 27 | 2004-M8x1x20 | | |
| AIKT-K-R/L-40-4-T12 | ● | ○ | 40 | 45 | 300 | 54 | 12 | 37.5 | 33 | 2004-M8x1x20 | | |
| AIKT-K-R/L-25-5-T7 | ● | ● | 25 | 31 | 200 | 43 | 7 | 23 | 18.5 | 2504-M5x16 | | |
| AIKT-K-R/L-32-5-T7 | ● | ● | 32 | 37 | 250 | 50 | 7 | 30 | 22 | 2504-M5x16 | | |
| AIKT-K-R/L-40-5-T7 | ● | ● | 40 | 45 | 300 | 54 | 7 | 37.5 | 27 | 2004-M8x1x20 | | |

R: Sağ/Right L: Sol/Left ● Stokta/In Stock ○ Stokta Yok/Non Stock Item
KRLY Ucuna Uygun. / Compatible with KRLY Insert.

Sipariş Örneği/Ordering Example : 1 ad./pcs. AIKT-K-R-16-2-T4

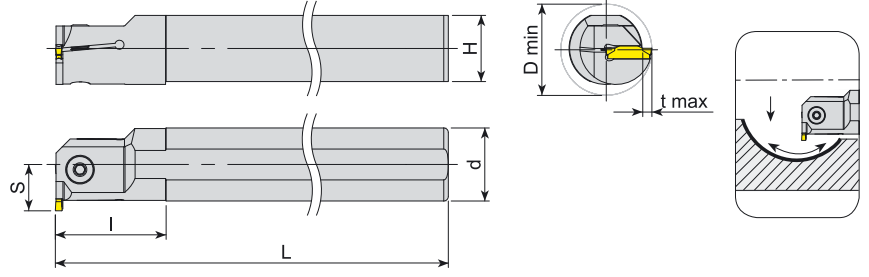

| Takım Kodu Ordering Code | Stok Stock | | Takım Ölçüleri (mm) Dimension (mm) | | | | | | Kesici Uç Insert | Yedek Parçaları Spare Parts | | |
|-----------------------------|---------------|---|---------------------------------------|----|-----|----|-------|----|---------------------|--------------------------------|-----------------------------|----------------------|
| | R | L | d | D | L | I | t max | H | | S | Sıkma Vidası Clamp Screw | Anahtar Allen Key |
| AIKT-KG-R/L-25-2-T7 | ○ | ○ | 25 | 32 | 200 | 45 | 7 | 23 | 19 | | | |
| AIKT-KG-R/L-25-3-T7 | ○ | ○ | 25 | 32 | 200 | 45 | 7 | 23 | 19 | | 2504-M5X16 | AAL-05-4 |
| AIKT-KG-R/L-25-4-T8 | ○ | ○ | 25 | 32 | 200 | 45 | 8 | 23 | 19 | | | |

KRLY Ucuna Uygundur. / Compatible with KRLY Insert.

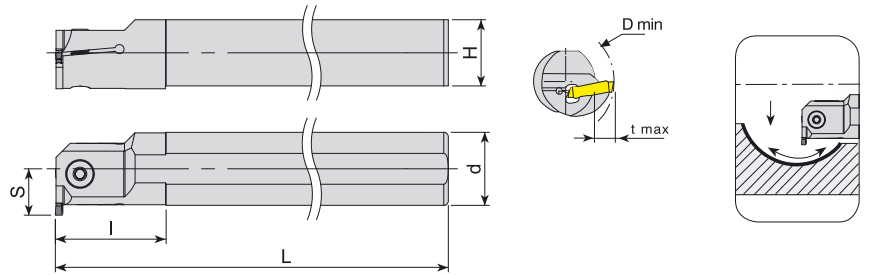

| Takım Kodu Ordering Code | Stok Stock | | Takım Ölçüleri (mm) Dimension (mm) | | | | | | Kesici Uç Insert | Yedek Parçaları Spare Parts | | |
|-----------------------------|---------------|---|---------------------------------------|----|-----|----|-------|------|---------------------|--------------------------------|-----------------------------|----------------------|
| | R | L | d | D | L | I | t max | H | | S | Sıkma Vidası Clamp Screw | Anahtar Allen Key |
| AIKT-H-R/L-25-3-T7 | ● | ● | 25 | 31 | 200 | 43 | 7 | 23 | 18.9 | | 2504-M5x16 | |
| AIKT-H-R/L-32-3-T7 | ● | ○ | 32 | 37 | 250 | 65 | 7 | 30 | 21.5 | | 2004-M8x1x20 | |
| AIKT-H-R/L-40-3-T7 | ● | ● | 40 | 45 | 300 | 50 | 7 | 37.5 | 26.5 | | | |
| AIKT-H-R/L-25-4-T7 | ● | ● | 25 | 31 | 200 | 40 | 7 | 23 | 18.9 | | 2504-M5x16 | AAL-05-4 |
| AIKT-H-R/L-32-4-T7 | ● | ● | 32 | 37 | 250 | 65 | 7 | 30 | 21.5 | | 2004-M8x1x20 | |
| AIKT-H-R/L-40-4-T7 | ● | ○ | 40 | 45 | 300 | 50 | 7 | 37.5 | 26.5 | | | |
| AIKT-H-R/L-25-5-T7 | ● | ● | 25 | 31 | 200 | 45 | 7 | 23 | 18.9 | | 2504-M5x16 | |
| AIKT-H-R/L-32-5-T7 | ● | ○ | 32 | 37 | 250 | 50 | 7 | 30 | 21.5 | | 2004-M8x1x20 | |
| AIKT-H-R/L-40-5-T7 | ● | ○ | 40 | 45 | 300 | 70 | 7 | 37.5 | 26.5 | | | |

R: Sağ/Right L: Sol/Left ● Stokta/In Stock ○ Stokta Yok/Non Stock Item
HRN Ucuna Uygundur. / Compatible with HRN Insert.

Sipariş Örneği/Ordering Example : 1 ad./pcs. AIKT-KG-R-25-2-T7

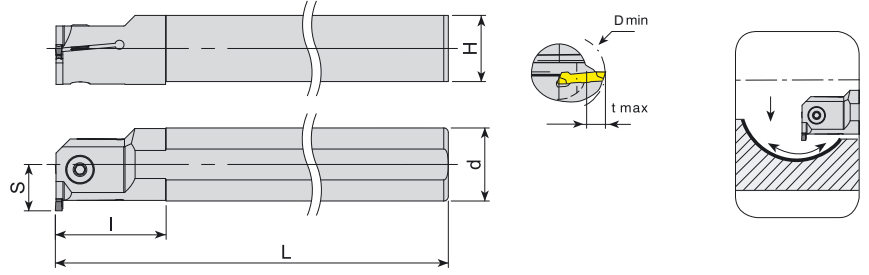

| Takım Kodu Ordering Code | Stok Stock | | Takım Ölçüleri (mm) Dimension (mm) | | | | | | Kesici Uç Insert | Yedek Parçaları Spare Parts | | |
|-----------------------------|---------------|---|---------------------------------------|----|-----|----|-------|------|---------------------|--------------------------------|-----------------------------|----------------------|
| | R | L | d | D | L | l | t max | H | | S | Sıkma Vidası Clamp Screw | Anahtar Allen Key |
| AIKT-HK-R/L-20-2-T6 | ● | ○ | 20 | 25 | 170 | 32 | 6 | 18.3 | 15 | S224 - 2 | 2503-M4x12 | AAL-03-3 |
| AIKT-HK-R/L-25-2-T6 | ● | ○ | 25 | 31 | 200 | 42 | 6 | 23 | 18.9 | | 2504-M5x16 | |
| AIKT-HK-R/L-20-3-T6 | ● | ○ | 20 | 25 | 170 | 33 | 6 | 18.3 | 15 | S224 - 3 | 2504-M5x12 | AAL-05-4 |
| AIKT-HK-R/L-25-3-T6 | ● | ○ | 25 | 31 | 200 | 43 | 6 | 23 | 18.9 | | 2504-M5x16 | |
| AIKT-HK-R/L-32-3-T6 | ● | ○ | 32 | 37 | 250 | 50 | 6 | 30 | 21.5 | 2004-M8x1x20 | | |
| AIKT-HK-R/L-20-4-T6 | ● | ○ | 20 | 25 | 170 | 34 | 6 | 18.3 | 15 | 2504-M5x12 | | |
| AIKT-HK-R/L-25-4-T6 | ● | ○ | 25 | 31 | 200 | 40 | 6 | 23 | 18.9 | S224 - 4 | 2504-M5x16 | |
| AIKT-HK-R/L-32-4-T6 | ● | ○ | 32 | 37 | 250 | 50 | 6 | 30 | 21.5 | | 2004-M8x1x20 | |
| AIKT-HS223-R/L-20-2-T5 | ● | ○ | 20 | 25 | 170 | 32 | 5 | 18.3 | 15 | S223 - 2 | 2503-M4x12 | AAL-03-3 |
| AIKT-HS223-R/L-25-2-T5 | ● | ○ | 25 | 31 | 200 | 42 | 5 | 23 | 18 | | 2504-M5x16 | AAL-05-4 |
| AIKT-HS223-R/L-20-3-T6 | ● | ○ | 20 | 25 | 170 | 32 | 6 | 18.3 | 15 | S223 - 3 | 2504-M5x12 | AAL-05-4 |
| AIKT-HS223-R/L-25-3-T6 | ● | ○ | 25 | 31 | 200 | 42 | 6 | 23 | 18 | | 2504-M5x16 | |

HRN Ucuna Uygundur. / Compatiple with HRN Insert.

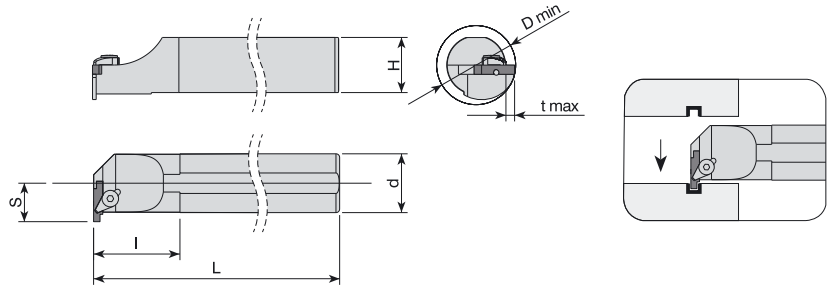

| Takım Kodu Ordering Code | Stok Stock | | Takım Ölçüleri (mm) Dimension (mm) | | | | | | Kesici Uç Insert | Yedek Parçaları Spare Parts | | | | |
|-----------------------------|---------------|---|---------------------------------------|----|-----|----|-------|------|---------------------|--------------------------------|------------------------------|------------------------------|------------|----------------------|
| | R | L | d | D | L | l | t max | H | | S | Baskı Parçası Wedge Clamp | Sıkma Vidası Clamp Screw | Pim Pin | Anahtar Allen Key |
| AIKT-154.91-R/L-16-3-T3 | ● | ● | 16 | 20 | 150 | 38 | 3 | 14.8 | 10.5 | 154.91 - 3 | ACK-06 | AKV-10-M6x14 | APM-06 | AAL-05-4 |
| AIKT-154.91-R/L-20-3-T4 | ● | ● | 20 | 25 | 170 | 40 | 4 | 18.3 | 13.5 | | | | | |
| AIKT-154.91-R/L-25-3-T4 | ● | ● | 25 | 31 | 200 | 42 | 4 | 23 | 16.5 | 154.91 - 5 | ACK-03 | AKV-21-M6x18 AKV-07-M6x22 | APM-06 | AAL-03-3 |
| AIKT-154.91-R/L-25-5-T5 | ● | ● | 25 | 31 | 200 | 42 | 5 | 23 | 16.5 | | | | | |
| AIKT-154.91-R/L-32-5-T5 | ● | ● | 32 | 39 | 250 | 49 | 5 | 30 | 21.5 | | | | | |

R: Sağ/Right L: Sol/Left ● Stokta/In Stock ○ Stokta Yok/Non Stock Item
SNDVK Ucuna Uygundur. / Compatiple with SNDVK Insert.

Sipariş Örneği/Ordering Example : 1 ad./pcs. AIKT-HK-R-20-2-T6

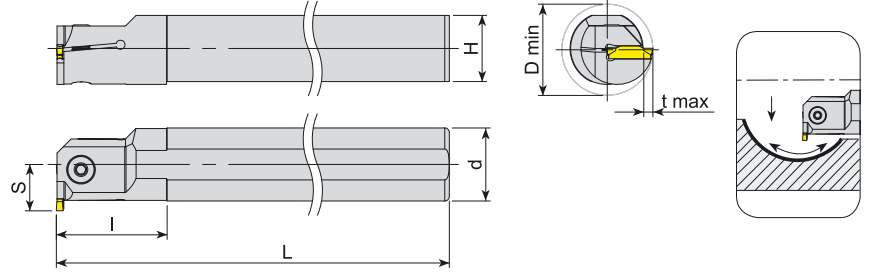

| Takım Kodu Ordering Code | Stok Stock | | Takım Ölçüleri (mm) Dimension (mm) | | | | | | | Kesici Uç Insert | Yedek Parçaları Spare Parts | |
|-----------------------------|---------------|---|---------------------------------------|----|-----|----|----------|------|----|---------------------|--------------------------------|----------------------|
| | R | L | d | D | L | l | t max | H | S | | Sıkma Vidası Clamp Screw | Anahtar Allen Key |
| AIKT-ZCC2-R/L-20-3-T5 | ● | ● | 20 | 25 | 170 | 32 | 5 | 18.3 | 15 | ZT.D - 3 | 2504-M5x12 | AAL-05-4 |
| AIKT-ZCC2-R/L-25-3-T5 | ● | ○ | 25 | 31 | 200 | 42 | 5 | 23 | 18 | | 2504-M5x16 | |
| AIKT-ZCC2-R/L-32-3-T6 | ● | ○ | 32 | 45 | 250 | 42 | 6 | 30 | 22 | 2004-M8x1x20 | | |
| AIKT-ZCC2-R/L-25-4-T6 | ● | ○ | 25 | 31 | 200 | 42 | 6 | 23 | 18 | 2504-M5x16 | | |
| AIKT-ZCC2-R/L-32-4-T7 | ● | ○ | 32 | 37 | 250 | 42 | 7 | 30 | 22 | 2004-M8x1x20 | | |
| AIKT-ZCC2-R/L-32-5-T7 | ● | ○ | 32 | 37 | 250 | 42 | 7 | 30 | 22 | | | |
| AIKT-ZCC2-R/L-40-5-T8 | ● | ○ | 40 | 45 | 300 | 53 | 8 | 37.5 | 27 | ZT.D - 5 | | |

ZCC Ucuna Uygundur. / Compatiple with ZCC Insert.

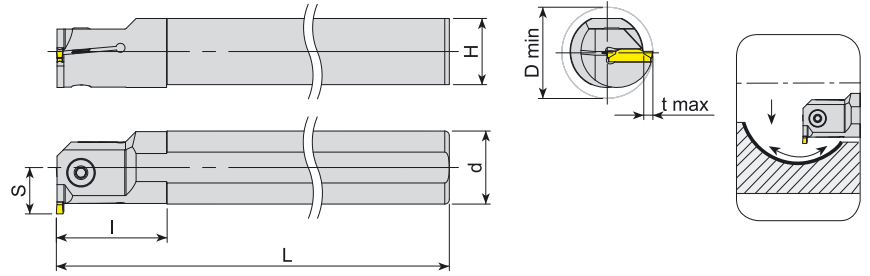

| Takım Kodu Ordering Code | Stok Stock | | Takım Ölçüleri (mm) Dimension (mm) | | | | | | | Kesici Uç Insert | Yedek Parçaları Spare Parts | |
|-----------------------------|---------------|---|---------------------------------------|----|-----|----|----------|------|----|---------------------|--------------------------------|----------------------|
| | R | L | d | D | L | l | t max | H | S | | Sıkma Vidası Clamp Screw | Anahtar Allen Key |
| AIKT-KM-R/L-20-2-T7 | ● | ○ | 20 | 25 | 200 | 40 | 7 | 18.3 | 13 | A4. - 2 | 2503-M4x12 | AAL-03-3 |
| AIKT-KM-R/L-20-3-T7 | ● | ○ | 20 | 25 | 200 | 40 | 7 | 18.3 | 13 | A4. - 3 | 2504-M5x12 | AAL-05-4 |
| AIKT-KM-R/L-25-3-T10 | ● | ● | 25 | 32 | 200 | 50 | 10 | 23 | 17 | | 2505-M6x16 | AAL-07-5 |
| AIKT-KM-R/L-32-3-T12 | ● | ○ | 32 | 40 | 250 | 64 | 12 | 30 | 22 | A4. - 4 | 2505-M6x20 | AAL-05-4 |
| AIKT-KM-R/L-40-3-T12 | ● | ● | 40 | 52 | 300 | 80 | 12 | 37.5 | 30 | | 2504-M5x12 | |
| AIKT-KM-R/L-20-4-T7 | ● | ○ | 20 | 25 | 200 | 40 | 7 | 18.3 | 13 | | | |

R: Sağ/Right L: Sol/Left ● Stokta/In Stock ○ Stokta Yok/Non Stock Item
KNMTL Ucuna Uygundur. / Compatiple with KNMTL Insert.

Sipariş Örneği/Ordering Example : 1 ad./pcs. AIKT-ZCC2-R-20-3-T5

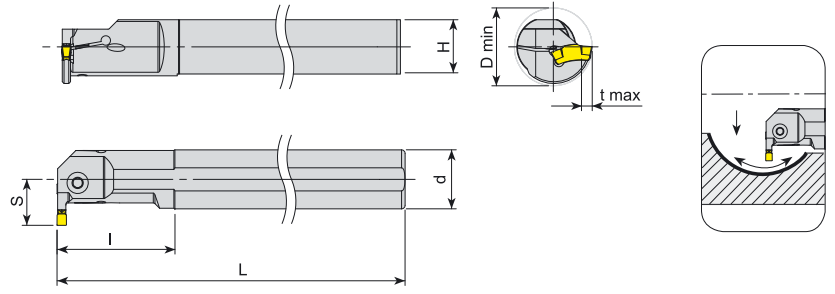

| Takım Kodu Ordering Code | Stok Stock | | Takım Ölçüleri (mm) Dimension (mm) | | | | | | | Kesici Uç Insert | Yedek Parçaları Spare Parts | |
|-----------------------------|---------------|---|---------------------------------------|----|-----|----|----------|------|------|---------------------|--------------------------------|----------------|
| | R | L | d | D | L | l | t max | H | S | | Sıkma Vidası Clamp Screw | Anahtar Key |
| AIKT-ITG-R/L-16-3-T6-H | ● | ● | 16 | 20 | 150 | 25 | 6 | 14.8 | 12 | TGM. - 3 | 1020-M4.5X14 | 80-T20 |
| AIKT-ITG-R/L-20-3-T6-H | ● | ● | 20 | 25 | 170 | 32 | 6 | 18.3 | 14.2 | | 1020-M4.5X16 | |
| AIKT-ITG-R/L-25-3-T8-H | ● | ● | 25 | 31 | 200 | 40 | 8 | 23 | 18.8 | | 2504-M5X16 | AAL-05-4 |
| AIKT-ITG-R/L-32-3-T8-H | ● | ○ | 32 | 37 | 250 | 49 | 8 | 30 | 25.5 | | 2004-M8x1x20 | |
| AIKT-ITG-R/L-20-4-T6-H | ● | ● | 20 | 25 | 170 | 33 | 6 | 18.3 | 14.2 | TGM. - 4 | 1020-M4.5X16 | 80-T20 |
| AIKT-ITG-R/L-25-4-T7-H | ● | ● | 25 | 31 | 200 | 41 | 7 | 23 | 17.5 | | 2504-M5X16 | AAL-05-4 |
| AIKT-ITG-R/L-25-4-T9-H | ● | ● | 25 | 31 | 200 | 41 | 9 | 23 | 19.5 | | 2004-M8x1x20 | |
| AIKT-ITG-R/L-32-4-T11-H | ● | ● | 32 | 37 | 250 | 50 | 11 | 30 | 25.5 | | 2004-M8x1x20 | |

ISCR Ucuna Uygunudur. / Compatiple with ISCR Insert.

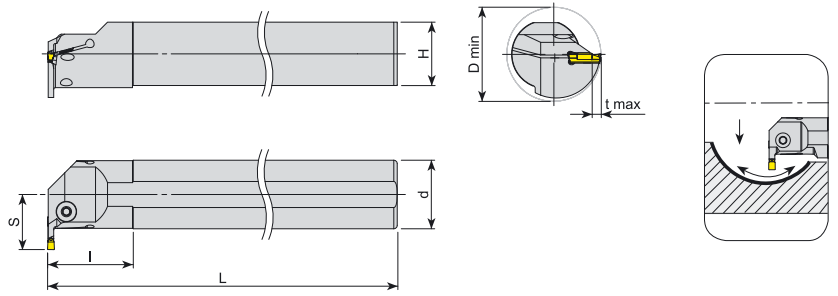





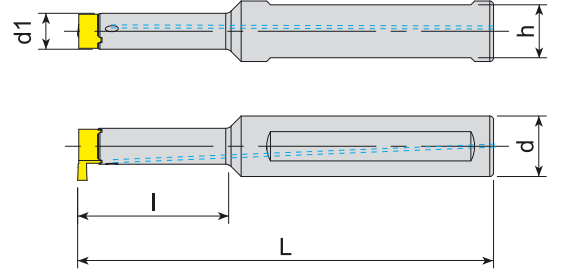
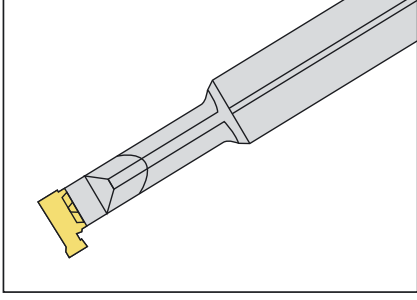

| Takım Kodu Ordering Code | Stok Stock | | Takım Ölçüleri (mm) Dimension (mm) | | | | | | | Kesici Uç Insert | Yedek Parçaları Spare Parts | |
|-----------------------------|---------------|---|---------------------------------------|----|-----|----|----------|------|------|---------------------|--------------------------------|----------------------|
| | R | L | d | D | L | l | t max | H | S | | Sıkma Vidası Clamp Screw | Anahtar Allen Key |
| AIKT-IG-R/L-25-4-T10-H | ● | ○ | 25 | 31 | 200 | 40 | 10 | 23 | 22.7 | DGN / GRP - 4 | 2504-M5X16 | AAL-05-4 |
| AIKT-IG-R/L-32-4-T10-H | ● | ○ | 32 | 37 | 250 | 45 | 10 | 30 | 26.2 | | 2004-M8x1x20 | |
| AIKT-IG-R/L-40-4-T12-H | ● | ○ | 40 | 45 | 300 | 50 | 12 | 37.5 | 32.2 | | 2504-M5X16 | |
| AIKT-IG-R/L-25-5-T10-H | ● | ○ | 25 | 31 | 200 | 40 | 10 | 23 | 22.7 | DGN / GRP - 5 | 2004-M8x1x20 | AAL-05-4 |
| AIKT-IG-R/L-32-5-T10-H | ● | ○ | 32 | 37 | 250 | 45 | 10 | 30 | 26.2 | | 2504-M5X16 | |
| AIKT-IG-R/L-40-5-T12-H | ● | ○ | 40 | 45 | 300 | 50 | 12 | 37.5 | 32.2 | | 2004-M8x1x20 | |
| AIKT-IG-R/L-50-5-T12-H | ● | ○ | 50 | 60 | 350 | 65 | 12 | 47 | 33 | | 2004-M8x1x20 | |

R: Sağ/Right L: Sol/Left ● Stokta/In Stock ○ Stokta Yok/Non Stock Item
ISCR Ucuna Uygunudur. / Compatiple with ISCR Insert.

Sipariş Örneği/Ordering Example : 1 ad./pcs. AIKT-IG-R-25-4-T10-H



| Takım Kodu Ordering Code | Stok Stock | Takım Ölçüleri (mm) Dimension (mm) | | | | | Kesici Uç Insert | Yedek Parçaları Spare Parts | |
|-----------------------------|---------------|---------------------------------------|-----|-----|----|----|---|---|---|
| | | d | d1 | L | l | h | | Sıkma Vidası Clamp Screw | Tork Anahtar Torx Key |
| AIKT-MB07-A16-090-15 | ○ | 16 | 7.4 | 90 | 15 | 14 |  |  |  |
| AIKT-MB07-A16-090-22 | ○ | 16 | 7.4 | 90 | 22 | 14 | | | |
| AIKT-MB09-A16-090-19 | ○ | 16 | 9.5 | 90 | 19 | 14 |  |  |  |
| AIKT-MB09-A16-095-28 | ○ | 16 | 9.5 | 95 | 28 | 14 | | | |
| AIKT-MB09-A16-110-40 | ○ | 16 | 9.5 | 110 | 40 | 14 | | | |

R: Sağ/Right L: Sol/Left ● Stokta/In Stock ○ Stokta Yok/Non Stock Item
SNDVK Ucuna Uygundur. / Compatible with SNDVK Insert.

Sipariş Örneği/Ordering Example : 1 ad./pcs. AIKT-MB07-R-16-16



DELİK DELME ve İŞLEME TAKIMLARI
DRILLING and HOLEMAKING TOOLS





*konusulan
the spoken kalite...
quality...*

U-DRILL

TAKMA UÇLU MATKAPLAR
U-DRILL SYSTEM





AKKO **A** **TUM** **16** x **D3**

S **P** **M** **T** **06** **02** **04**

2 Kesiş Stili / Cutter Style

TUM : Takma Uçlu Matkap / U-Drill

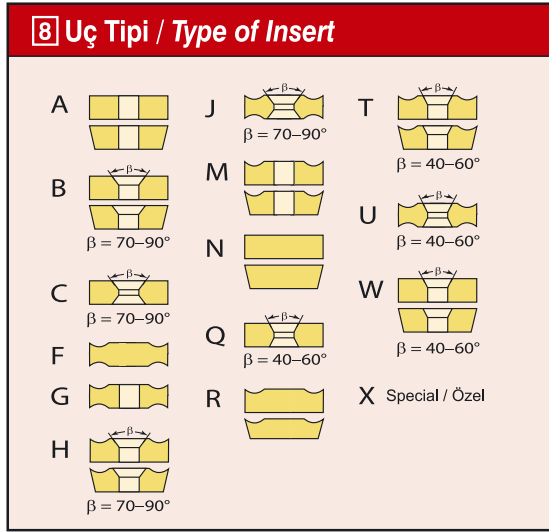
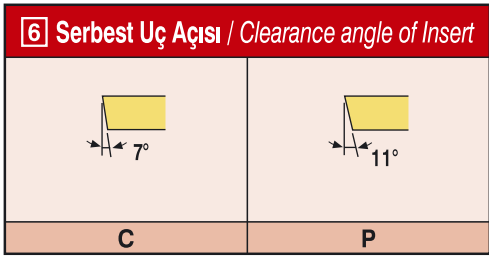
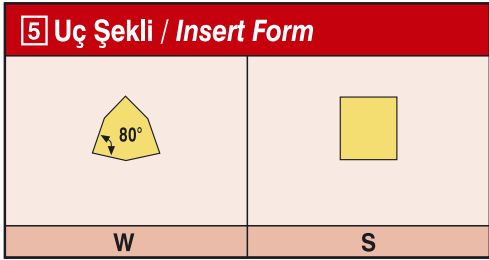
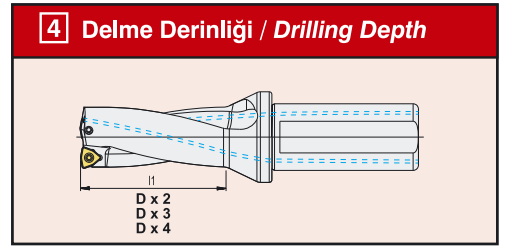
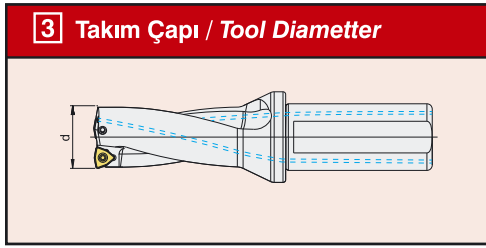

10 Kalınlık / Thickness

| | |
|----|----------|
| 01 | s = 1.59 |
| T1 | s = 1.98 |
| 02 | s = 2.38 |
| T2 | s = 2.78 |
| 03 | s = 3.18 |
| T3 | s = 3.97 |
| 04 | s = 4.76 |
| 05 | s = 5.56 |
| 06 | s = 6.35 |
| 07 | s = 7.94 |
| 09 | s = 9.52 |

7 Toleranslar / Tolerance Classes

| | d | m | t |
|---|-------------|-------------|---------|
| A | ± 0.025 | ± 0.005 | ± 0.025 |
| C | ± 0.025 | ± 0.013 | ± 0.025 |
| E | ± 0.025 | ± 0.025 | ± 0.025 |
| F | ± 0.013 | ± 0.005 | ± 0.025 |
| G | ± 0.025 | ± 0.025 | ± 0.130 |
| H | ± 0.013 | ± 0.013 | ± 0.025 |
| J | ± 0.05-0.15 | ± 0.005 | ± 0.025 |
| K | ± 0.05-0.15 | ± 0.013 | ± 0.025 |
| L | ± 0.05-0.15 | ± 0.025 | ± 0.025 |
| M | ± 0.05-0.15 | ± 0.08-0.20 | ± 0.130 |
| N | ± 0.05-0.15 | ± 0.08-0.20 | ± 0.025 |
| U | ± 0.08-0.25 | ± 0.13-0.38 | ± 0.130 |

d : Daire Ölçüsü / Inscribed Circle
m : Şekle Göre / Refer to Figure
t : Kalınlık / Thickness

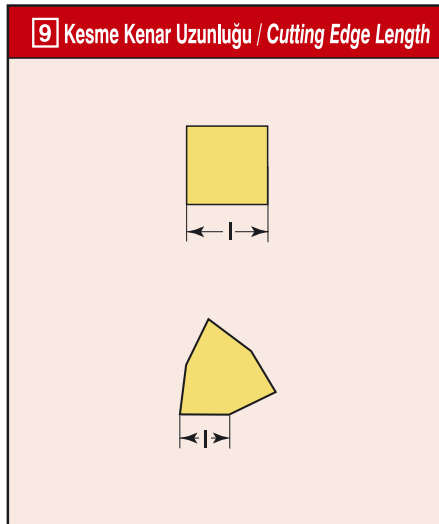

11 Köşe Konfigürasyonu / Corner Radius

| | |
|----|---------|
| 01 | r = 0.1 |
| 02 | r = 0.2 |
| 04 | r = 0.4 |
| 08 | r = 0.8 |
| 12 | r = 1.2 |
| 16 | r = 1.6 |
| 24 | r = 2.4 |



Delme Derinliği = 2xÇap
Drilling Depth = 2xDiameter

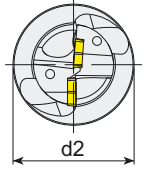
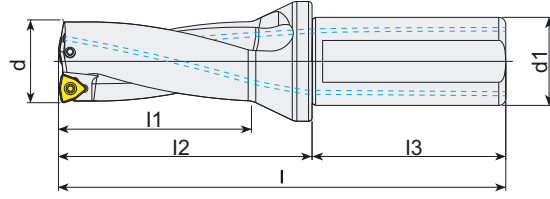

| Takım Kodu Ordering Code | Stok Stock | Takım Ölçüleri (mm) Dimension (mm) | | | | | | | Kesici Uç Insert | Yedek Parçaları Spare Parts | | | | |
|-----------------------------|---------------|---------------------------------------|----|----|-----|----|----|----|---------------------|--------------------------------|--------------------------|-------------|-------------|--------|
| | | d | d1 | d2 | l | l1 | l2 | l3 | | Sıkma Vidası Screw | Tork Anahtar Torx Key | | | |
| ATUM 16XD2 WCM. 030208 | ● | 16 | 25 | 34 | 110 | 32 | 54 | 56 | WCM. 030208 | 3008-M2.5x6 | 80-T08 | | | |
| ATUM 16.5XD2 WCM. 030208 | ● | 16.5 | 25 | 34 | 110 | 32 | 54 | 56 | | | | | | |
| ATUM 17XD2 WCM. 030208 | ● | 17 | 25 | 34 | 112 | 34 | 56 | 56 | | | | | | |
| ATUM 17.5XD2 WCM. 030208 | ● | 17.5 | 25 | 34 | 112 | 34 | 56 | 56 | | | | | | |
| ATUM 18XD2 WCM. 030208 | ● | 18 | 25 | 34 | 114 | 36 | 58 | 56 | | | | | | |
| ATUM 18.5XD2 WCM. 030208 | ● | 18.5 | 25 | 34 | 114 | 36 | 58 | 56 | | | | | | |
| ATUM 19XD2 WCM. 030208 | ● | 19 | 25 | 34 | 116 | 38 | 60 | 56 | | | | | | |
| ATUM 19.5XD2 WCM. 030208 | ● | 19.5 | 25 | 34 | 116 | 38 | 60 | 56 | | | | | | |
| ATUM 20XD2 WCM. 040208 | ● | 20 | 25 | 34 | 118 | 40 | 62 | 56 | | | | WCM. 040208 | 3008-M2.5x6 | 80-T08 |
| ATUM 20.5XD2 WCM. 040208 | ● | 20.5 | 25 | 34 | 118 | 40 | 62 | 56 | | | | | | |
| ATUM 21XD2 WCM. 040208 | ● | 21 | 25 | 34 | 120 | 42 | 64 | 56 | | | | | | |
| ATUM 21.5XD2 WCM. 040208 | ● | 21.5 | 25 | 34 | 120 | 42 | 64 | 56 | | | | | | |
| ATUM 22XD2 WCM. 040208 | ● | 22 | 25 | 34 | 122 | 44 | 66 | 56 | | | | | | |
| ATUM 22.5XD2 WCM. 040208 | ● | 22.5 | 25 | 34 | 122 | 44 | 66 | 56 | | | | | | |
| ATUM 23XD2 WCM. 040208 | ● | 23 | 25 | 34 | 124 | 46 | 68 | 56 | | | | | | |
| ATUM 23.5XD2 WCM. 040208 | ● | 23.5 | 25 | 34 | 124 | 46 | 68 | 56 | | | | | | |
| ATUM 24XD2 WCM. 050308 | ● | 24 | 25 | 34 | 126 | 48 | 70 | 56 | WCM. 050308 | 1008-M3x8 | | | | |
| ATUM 24.5XD2 WCM. 050308 | ● | 24.5 | 25 | 34 | 126 | 48 | 70 | 56 | | | | | | |
| ATUM 25XD2 WCM. 050308 | ● | 25 | 25 | 34 | 128 | 50 | 72 | 56 | | | | | | |
| ATUM 25.5XD2 WCM. 050308 | ● | 25.5 | 25 | 34 | 128 | 50 | 72 | 56 | | | | | | |
| ATUM 26XD2 WCM. 050308 | ● | 26 | 25 | 34 | 130 | 52 | 74 | 56 | | | | | | |
| ATUM 26.5XD2 WCM. 050308 | ● | 26.5 | 25 | 34 | 130 | 52 | 74 | 56 | | | | | | |
| ATUM 27XD2 WCM. 050308 | ● | 27 | 25 | 34 | 132 | 54 | 76 | 56 | | | | | | |
| ATUM 27.5XD2 WCM. 050308 | ● | 27.5 | 25 | 34 | 132 | 54 | 76 | 56 | | | | | | |
| ATUM 28XD2 WCM. 050308 | ● | 28 | 25 | 34 | 134 | 56 | 78 | 56 | | | | | | |
| ATUM 28.5XD2 WCM. 050308 | ● | 28.5 | 25 | 34 | 134 | 56 | 78 | 56 | | | | | | |
| ATUM 29XD2 WCM. 050308 | ● | 29 | 25 | 34 | 136 | 58 | 80 | 56 | | | | | | |
| ATUM 29.5XD2 WCM. 050308 | ● | 29.5 | 25 | 34 | 136 | 58 | 80 | 56 | | | | | | |

R: Sağ/Right L: Sol/Left ● Stokta/In Stock ○ Stokta Yok/Non Stock Item
ISO Ucuna Uygunudur. / Compatiple with ISO Insert.

Sipariş Örneği/Ordering Example : 1 ad./pcs. ATUM 16xD2 WCM. 030208
Takma Uçlu Matkap Kullanım Kılavuzu : S 210 / User's Guide For U-Drills : P 210

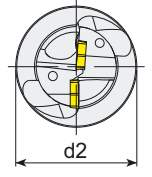
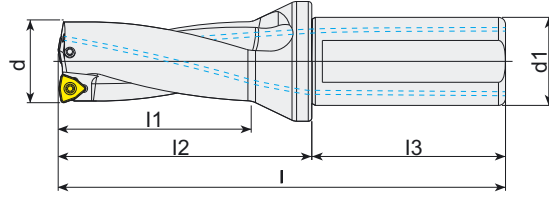

Delme Derinliği = 2xÇap
Drilling Depth = 2xDiameter

| Takım Kodu Ordering Code | Stok Stock | Takım Ölçüleri (mm) Dimension (mm) | | | | | | | Kesici Uç Insert | Yedek Parçaları Spare Parts | |
|-----------------------------|---------------|---------------------------------------|----|----|-----|-----|-----|----|---------------------|--------------------------------|--------------------------|
| | | d | d1 | d2 | l | l1 | l2 | l3 | | Sıkma Vidası Screw | Tork Anahtar Torx Key |
| ATUM 30XD2 WCM. 06T308 | ● | 30 | 32 | 44 | 147 | 60 | 87 | 60 | WCM. 06T308 | 1510-M3.5x9 | 80-T10 |
| ATUM 31XD2 WCM. 06T308 | ● | 31 | 32 | 44 | 149 | 62 | 89 | 60 | | | |
| ATUM 32XD2 WCM. 06T308 | ● | 32 | 32 | 44 | 151 | 64 | 91 | 60 | | | |
| ATUM 33XD2 WCM. 06T308 | ● | 33 | 32 | 44 | 153 | 66 | 93 | 60 | | | |
| ATUM 34XD2 WCM. 06T308 | ● | 34 | 32 | 44 | 155 | 68 | 95 | 60 | | | |
| ATUM 35XD2 WCM. 06T308 | ● | 35 | 32 | 44 | 157 | 70 | 97 | 60 | | | |
| ATUM 36XD2 WCM. 06T308 | ● | 36 | 32 | 44 | 159 | 72 | 99 | 60 | | | |
| ATUM 37XD2 WCM. 06T308 | ● | 37 | 32 | 44 | 161 | 74 | 101 | 60 | | | |
| ATUM 38XD2 WCM. 06T308 | ● | 38 | 32 | 44 | 163 | 76 | 103 | 60 | | | |
| ATUM 39XD2 WCM. 06T308 | ● | 39 | 32 | 44 | 165 | 78 | 105 | 60 | | | |
| ATUM 40XD2 WCM. 06T308 | ● | 40 | 32 | 44 | 167 | 80 | 107 | 60 | | | |
| ATUM 41XD2 WCM. 06T308 | ● | 41 | 32 | 44 | 169 | 82 | 109 | 60 | | | |
| ATUM 42XD2 WCM. 06T308 | ● | 42 | 32 | 44 | 171 | 84 | 111 | 60 | | | |
| ATUM 43XD2 WCM. 06T308 | ● | 43 | 32 | 44 | 173 | 86 | 113 | 60 | | | |
| ATUM 44XD2 WCM. 06T308 | ● | 44 | 32 | 44 | 175 | 88 | 115 | 60 | | | |
| ATUM 45XD2 WCM. 080412 | ● | 45 | 40 | 54 | 192 | 90 | 122 | 70 | WCM. 080412 | 1515-M4x11 | 80-T15 |
| ATUM 46XD2 WCM. 080412 | ● | 46 | 40 | 54 | 194 | 92 | 124 | 70 | | | |
| ATUM 47XD2 WCM. 080412 | ● | 47 | 40 | 54 | 196 | 94 | 126 | 70 | | | |
| ATUM 48XD2 WCM. 080412 | ● | 48 | 40 | 54 | 198 | 96 | 128 | 70 | | | |
| ATUM 49XD2 WCM. 080412 | ● | 49 | 40 | 54 | 200 | 98 | 130 | 70 | | | |
| ATUM 50XD2 WCM. 080412 | ● | 50 | 40 | 54 | 202 | 100 | 132 | 70 | | | |
| ATUM 51XD2 WCM. 080412 | ● | 51 | 40 | 54 | 204 | 102 | 134 | 70 | | | |
| ATUM 52XD2 WCM. 080412 | ● | 52 | 40 | 54 | 206 | 104 | 136 | 70 | | | |
| ATUM 53XD2 WCM. 080412 | ● | 53 | 40 | 54 | 208 | 106 | 138 | 70 | | | |
| ATUM 54XD2 WCM. 080412 | ● | 54 | 40 | 54 | 210 | 108 | 140 | 70 | | | |
| ATUM 55XD2 WCM. 080412 | ● | 55 | 40 | 54 | 212 | 110 | 142 | 70 | | | |
| ATUM 56XD2 WCM. 080412 | ● | 56 | 40 | 59 | 214 | 112 | 144 | 70 | | | |
| ATUM 57XD2 WCM. 080412 | ● | 57 | 40 | 59 | 216 | 114 | 146 | 70 | | | |
| ATUM 58XD2 WCM. 080412 | ● | 58 | 40 | 59 | 218 | 116 | 148 | 70 | | | |
| ATUM 59XD2 WCM. 080412 | ● | 59 | 40 | 59 | 220 | 118 | 150 | 70 | | | |
| ATUM 60XD2 WCM. 080412 | ● | 60 | 40 | 59 | 222 | 120 | 152 | 70 | | | |

R: Sağ/Right L: Sol/Left ● Stokta/In Stock ○ Stokta Yok/Non Stock Item
ISO Ucuna Uygundur. / Compatible with ISO Insert.

Sipariş Örneği/Ordering Example : 1 ad./pcs. ATUM 30XD2 WCM. 06T308
Takma Uçlu Matkap Kullanım Kılavuzu : S 210 / User's Guide For U-Drills : P 210



Delme Derinliği = 3xÇap
Drilling Depth = 3xDiameter

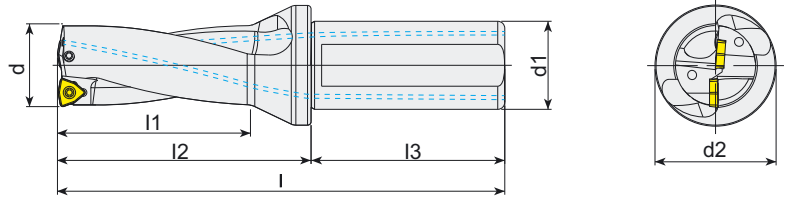



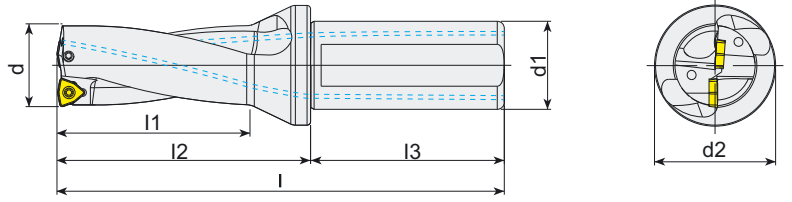

| Takım Kodu Ordering Code | Stok Stock | Takım Ölçüleri (mm) Dimension (mm) | | | | | | | Kesici Uç Insert | Yedek Parçaları Spare Parts | |
|-----------------------------|---------------|---------------------------------------|----------------|----------------|-----|----------------|----------------|----------------|---------------------|--------------------------------|--------------------------|
| | | d | d ₁ | d ₂ | l | l ₁ | l ₂ | l ₃ | | Sıkma Vidası Screw | Tork Anahtar Torx Key |
| ATUM 16XD3 WCM. 030208 | ● | 16 | 25 | 34 | 126 | 48 | 70 | 56 | WCM. 030208 | 3008-M2.5x6 | 80-T08 |
| ATUM 16.5XD3 WCM. 030208 | ● | 16.5 | 25 | 34 | 126 | 48 | 70 | 56 | | | |
| ATUM 17XD3 WCM. 030208 | ● | 17 | 25 | 34 | 129 | 51 | 73 | 56 | | | |
| ATUM 17.5XD3 WCM. 030208 | ● | 17.5 | 25 | 34 | 129 | 51 | 73 | 56 | | | |
| ATUM 18XD3 WCM. 030208 | ● | 18 | 25 | 34 | 132 | 54 | 76 | 56 | | | |
| ATUM 18.5XD3 WCM. 030208 | ● | 18.5 | 25 | 34 | 132 | 54 | 76 | 56 | | | |
| ATUM 19XD3 WCM. 030208 | ● | 19 | 25 | 34 | 135 | 57 | 79 | 56 | | | |
| ATUM 19.5XD3 WCM. 030208 | ● | 19.5 | 25 | 34 | 135 | 57 | 79 | 56 | | | |
| ATUM 20XD3 WCM. 040208 | ● | 20 | 25 | 34 | 138 | 60 | 82 | 56 | | | |
| ATUM 20.5XD3 WCM. 040208 | ● | 20.5 | 25 | 34 | 138 | 60 | 82 | 56 | | | |
| ATUM 21XD3 WCM. 040208 | ● | 21 | 25 | 34 | 141 | 63 | 85 | 56 | | | |
| ATUM 21.5XD3 WCM. 040208 | ● | 21.5 | 25 | 34 | 141 | 63 | 85 | 56 | | | |
| ATUM 22XD3 WCM. 040208 | ● | 22 | 25 | 34 | 144 | 66 | 88 | 56 | | | |
| ATUM 22.5XD3 WCM. 040208 | ● | 22.5 | 25 | 34 | 144 | 66 | 88 | 56 | | | |
| ATUM 23XD3 WCM. 040208 | ● | 23 | 25 | 34 | 147 | 69 | 91 | 56 | | | |
| ATUM 23.5XD3 WCM. 040208 | ● | 23.5 | 25 | 34 | 147 | 69 | 91 | 56 | | | |
| ATUM 24XD3 WCM. 050308 | ● | 24 | 25 | 34 | 150 | 72 | 94 | 56 | WCM. 050308 | 1008-M3x8 | 80-T08 |
| ATUM 24.5XD3 WCM. 050308 | ● | 24.5 | 25 | 34 | 150 | 72 | 94 | 56 | | | |
| ATUM 25XD3 WCM. 050308 | ● | 25 | 25 | 34 | 153 | 75 | 97 | 56 | | | |
| ATUM 25.5XD3 WCM. 050308 | ● | 25.5 | 25 | 34 | 153 | 75 | 97 | 56 | | | |
| ATUM 26XD3 WCM. 050308 | ● | 26 | 25 | 34 | 156 | 78 | 100 | 56 | | | |
| ATUM 26.5XD3 WCM. 050308 | ● | 26.5 | 25 | 34 | 156 | 78 | 100 | 56 | | | |
| ATUM 27XD3 WCM. 050308 | ● | 27 | 25 | 34 | 159 | 81 | 103 | 56 | | | |
| ATUM 27.5XD3 WCM. 050308 | ● | 27.5 | 25 | 34 | 159 | 81 | 103 | 56 | | | |
| ATUM 28XD3 WCM. 050308 | ● | 28 | 25 | 34 | 162 | 84 | 106 | 56 | | | |
| ATUM 28.5XD3 WCM. 050308 | ● | 28.5 | 25 | 34 | 162 | 84 | 106 | 56 | | | |
| ATUM 29XD3 WCM. 050308 | ● | 29 | 25 | 34 | 165 | 87 | 109 | 56 | WCM. 06T308 | 1510-M3.5x9 | 80-T10 |
| ATUM 29.5XD3 WCM. 050308 | ● | 29.5 | 25 | 34 | 165 | 87 | 109 | 56 | | | |
| ATUM 30XD3 WCM. 06T308 | ● | 30 | 32 | 44 | 177 | 90 | 117 | 60 | | | |
| ATUM 30.5XD3 WCM. 06T308 | ● | 30.5 | 32 | 44 | 177 | 90 | 117 | 60 | | | |
| ATUM 31XD3 WCM. 06T308 | ● | 31 | 32 | 44 | 180 | 93 | 120 | 60 | | | |
| ATUM 31.5XD3 WCM. 06T308 | ● | 31.5 | 32 | 44 | 180 | 93 | 120 | 60 | | | |
| ATUM 32XD3 WCM. 06T308 | ● | 32 | 32 | 44 | 183 | 96 | 123 | 60 | | | |
| ATUM 32.5XD3 WCM. 06T308 | ● | 32.5 | 32 | 44 | 183 | 96 | 123 | 60 | | | |
| ATUM 33XD3 WCM. 06T308 | ● | 33 | 32 | 44 | 186 | 99 | 126 | 60 | | | |
| ATUM 33.5XD3 WCM. 06T308 | ● | 33.5 | 32 | 44 | 186 | 99 | 126 | 60 | | | |
| ATUM 34XD3 WCM. 06T308 | ● | 34 | 32 | 44 | 189 | 102 | 129 | 60 | | | |
| ATUM 34.5XD3 WCM. 06T308 | ● | 34.5 | 32 | 44 | 189 | 102 | 129 | 60 | | | |

R: Sağ/Right L: Sol/Left ● Stokta/In Stock ○ Stokta Yok/Non Stock Item
ISO Ucuna Uygunudur. / Compatible with ISO Insert.

Sipariş Örneği/Ordering Example : 1 ad./pcs. ATUM 16xD3 WCM. 030208
Takma Uçlu Matkap Kullanım Kılavuzu : S 210 / User's Guide For U-Drills : P 210

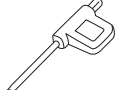

Delme Derinliği = 3xÇap
Drilling Depth = 3xDiameter

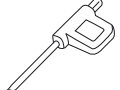
| Takım Kodu Ordering Code | Stok Stock | Takım Ölçüleri (mm) Dimension (mm) | | | | | | | Kesici Uç Insert | Yedek Parçaları Spare Parts | | | | |
|-----------------------------|---------------|---------------------------------------|----------------|----------------|-----|----------------|----------------|----------------|--|---|---|--|---|---|
| | | d | d ₁ | d ₂ | l | l ₁ | l ₂ | l ₃ | | Sıkma Vidası Screw | Tork Anahtar Torx Key | | | |
| ATUM 35XD3 WCM. 06T308 | ● | 35 | 32 | 44 | 192 | 105 | 132 | 60 |  |  |  | | | |
| ATUM 35.5XD3 WCM. 06T308 | ● | 35.5 | 32 | 44 | 192 | 105 | 132 | 60 | | | | | | |
| ATUM 36XD3 WCM. 06T308 | ● | 36 | 32 | 44 | 195 | 108 | 135 | 60 | | | | | | |
| ATUM 36.5XD3 WCM. 06T308 | ● | 36.5 | 32 | 44 | 195 | 108 | 135 | 60 | | | | | | |
| ATUM 37XD3 WCM. 06T308 | ● | 37 | 32 | 44 | 198 | 111 | 138 | 60 | | | | | | |
| ATUM 37.5XD3 WCM. 06T308 | ● | 37.5 | 32 | 44 | 198 | 111 | 138 | 60 | | | | | | |
| ATUM 38XD3 WCM. 06T308 | ● | 38 | 32 | 44 | 201 | 114 | 141 | 60 | | | | | | |
| ATUM 38.5XD3 WCM. 06T308 | ● | 38.5 | 32 | 44 | 201 | 114 | 141 | 60 | | | | | | |
| ATUM 39XD3 WCM. 06T308 | ● | 39 | 32 | 44 | 204 | 117 | 144 | 60 | | | | | | |
| ATUM 39.5XD3 WCM. 06T308 | ● | 39.5 | 32 | 44 | 204 | 117 | 144 | 60 | | | | | | |
| ATUM 40XD3 WCM. 06T308 | ● | 40 | 32 | 44 | 207 | 120 | 147 | 60 | | | | | | |
| ATUM 40.5XD3 WCM. 06T308 | ● | 40.5 | 32 | 44 | 207 | 120 | 147 | 60 | | | | | | |
| ATUM 41XD3 WCM. 06T308 | ● | 41 | 32 | 44 | 210 | 123 | 150 | 60 | | | | | | |
| ATUM 41.5XD3 WCM. 06T308 | ● | 41.5 | 32 | 44 | 210 | 123 | 150 | 60 | | | | | | |
| ATUM 42XD3 WCM. 06T308 | ● | 42 | 32 | 44 | 213 | 126 | 153 | 60 | | | | | | |
| ATUM 42.5XD3 WCM. 06T308 | ● | 42.5 | 32 | 44 | 213 | 126 | 153 | 60 | | | | | | |
| ATUM 43XD3 WCM. 06T308 | ● | 43 | 32 | 44 | 216 | 129 | 156 | 60 | | | | | | |
| ATUM 43.5XD3 WCM. 06T308 | ● | 43.5 | 32 | 44 | 216 | 129 | 156 | 60 | | | | | | |
| ATUM 44XD3 WCM. 06T308 | ● | 44 | 32 | 44 | 219 | 132 | 159 | 60 | | | | | | |
| ATUM 44.5XD3 WCM. 06T308 | ● | 44.5 | 32 | 44 | 219 | 132 | 159 | 60 | | | | | | |
| ATUM 45XD3 WCM. 080412 | ● | 45 | 40 | 54 | 237 | 135 | 167 | 70 | | | |  |  |  |
| ATUM 45.5XD3 WCM. 080412 | ● | 45.5 | 40 | 54 | 237 | 135 | 167 | 70 | | | | | | |
| ATUM 46XD3 WCM. 080412 | ● | 46 | 40 | 54 | 240 | 138 | 170 | 70 | | | | | | |
| ATUM 47XD3 WCM. 080412 | ● | 47 | 40 | 54 | 243 | 141 | 173 | 70 | | | | | | |
| ATUM 48XD3 WCM. 080412 | ● | 48 | 40 | 54 | 246 | 144 | 176 | 70 | | | | | | |
| ATUM 49XD3 WCM. 080412 | ● | 49 | 40 | 54 | 249 | 147 | 179 | 70 | | | | | | |
| ATUM 50XD3 WCM. 080412 | ● | 50 | 40 | 54 | 252 | 150 | 182 | 70 | | | | | | |
| ATUM 51XD3 WCM. 080412 | ● | 51 | 40 | 54 | 255 | 153 | 185 | 70 | | | | | | |
| ATUM 52XD3 WCM. 080412 | ● | 52 | 40 | 54 | 258 | 156 | 188 | 70 | | | | | | |
| ATUM 53XD3 WCM. 080412 | ● | 53 | 40 | 54 | 261 | 159 | 191 | 70 | | | | | | |
| ATUM 54XD3 WCM. 080412 | ● | 54 | 40 | 54 | 264 | 162 | 194 | 70 | | | | | | |
| ATUM 55XD3 WCM. 080412 | ● | 55 | 40 | 54 | 267 | 165 | 197 | 70 | | | | | | |
| ATUM 56XD3 WCM. 080412 | ● | 56 | 40 | 59 | 270 | 168 | 200 | 70 | | | | | | |
| ATUM 57XD3 WCM. 080412 | ● | 57 | 40 | 59 | 273 | 171 | 203 | 70 | | | | | | |
| ATUM 58XD3 WCM. 080412 | ● | 58 | 40 | 59 | 276 | 174 | 206 | 70 | | | | | | |
| ATUM 59XD3 WCM. 080412 | ● | 59 | 40 | 59 | 279 | 177 | 209 | 70 | | | | | | |
| ATUM 60XD3 WCM. 080412 | ● | 60 | 40 | 59 | 282 | 180 | 212 | 70 | | | | | | |

R: Sağ/Right L: Sol/Left ● Stokta/In Stock ○ Stokta Yok/Non Stock Item
ISO Ucuna Uygundur. / Compatible with ISO Insert.

Sipariş Örneği/Ordering Example : 1 ad./pcs. ATUM 35xD3 WCM. 06T308
Takma Uçlu Matkap Kullanım Kılavuzu : S 210 / User's Guide For U-Drills : P 210



Delme Derinliği = 4xÇap
Drilling Depth = 4xDiameter

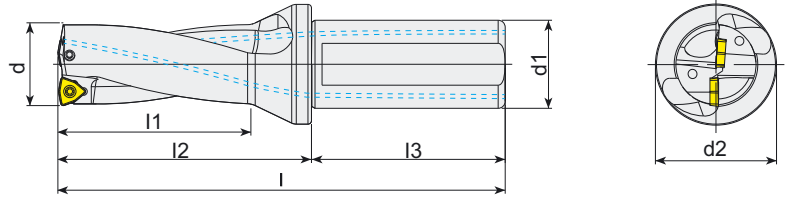

| Takım Kodu Ordering Code | Stok Stock | Takım Ölçüleri (mm) Dimension (mm) | | | | | | | Kesici Uç Insert | Yedek Parçaları Spare Parts | |
|-----------------------------|---------------|---------------------------------------|----------------|----------------|-----|----------------|----------------|----------------|---------------------|--------------------------------|--------------------------|
| | | d | d ₁ | d ₂ | l | l ₁ | l ₂ | l ₃ | | Sıkma Vidası Screw | Tork Anahtar Torx Key |
| ATUM 16XD4 WCM. 030208 | ● | 16 | 25 | 34 | 142 | 64 | 86 | 56 | WCM. 030208 | | |
| ATUM 16.5XD4 WCM. 030208 | ○ | 16.5 | 25 | 34 | 142 | 64 | 86 | 56 | | | |
| ATUM 17XD4 WCM. 030208 | ● | 17 | 25 | 34 | 146 | 68 | 90 | 56 | | | |
| ATUM 17.5XD4 WCM. 030208 | ○ | 17.5 | 25 | 34 | 146 | 68 | 90 | 56 | | | |
| ATUM 18XD4 WCM. 030208 | ● | 18 | 25 | 34 | 150 | 72 | 94 | 56 | | | |
| ATUM 18.5XD4 WCM. 030208 | ○ | 18.5 | 25 | 34 | 150 | 72 | 94 | 56 | | | |
| ATUM 19XD4 WCM. 030208 | ● | 19 | 25 | 34 | 154 | 76 | 98 | 56 | | | |
| ATUM 19.5XD4 WCM. 030208 | ○ | 19.5 | 25 | 34 | 154 | 76 | 98 | 56 | | | |
| ATUM 20XD4 WCM. 040208 | ● | 20 | 25 | 34 | 158 | 80 | 102 | 56 | WCM. 040208 | 3008-M2.5x6 | 80-T08 |
| ATUM 20.5XD4 WCM. 040208 | ○ | 20.5 | 25 | 34 | 158 | 80 | 102 | 56 | | | |
| ATUM 21XD4 WCM. 040208 | ● | 21 | 25 | 34 | 162 | 84 | 106 | 56 | | | |
| ATUM 21.5XD4 WCM. 040208 | ○ | 21.5 | 25 | 34 | 162 | 84 | 106 | 56 | | | |
| ATUM 22XD4 WCM. 040208 | ● | 22 | 25 | 34 | 166 | 88 | 110 | 56 | | | |
| ATUM 22.5XD4 WCM. 040208 | ○ | 22.5 | 25 | 34 | 166 | 88 | 110 | 56 | | | |
| ATUM 23XD4 WCM. 040208 | ● | 23 | 25 | 34 | 170 | 92 | 114 | 56 | | | |
| ATUM 23.5XD4 WCM. 040208 | ○ | 23.5 | 25 | 34 | 170 | 92 | 114 | 56 | | | |
| ATUM 24XD4 WCM. 050308 | ● | 24 | 25 | 34 | 174 | 96 | 118 | 56 | WCM. 050308 | 1008-M3x8 | |
| ATUM 24.5XD4 WCM. 050308 | ○ | 24.5 | 25 | 34 | 174 | 96 | 118 | 56 | | | |
| ATUM 25XD4 WCM. 050308 | ● | 25 | 25 | 34 | 178 | 100 | 122 | 56 | | | |
| ATUM 25.5XD4 WCM. 050308 | ○ | 25.5 | 25 | 34 | 178 | 100 | 122 | 56 | | | |
| ATUM 26XD4 WCM. 050308 | ● | 26 | 25 | 34 | 182 | 104 | 126 | 56 | | | |
| ATUM 26.5XD4 WCM. 050308 | ○ | 26.5 | 25 | 34 | 182 | 104 | 126 | 56 | | | |
| ATUM 27XD4 WCM. 050308 | ● | 27 | 25 | 34 | 186 | 108 | 130 | 56 | | | |
| ATUM 27.5XD4 WCM. 050308 | ○ | 27.5 | 25 | 34 | 186 | 108 | 130 | 56 | | | |
| ATUM 28XD4 WCM. 050308 | ● | 28 | 25 | 34 | 190 | 112 | 134 | 56 | | | |
| ATUM 28.5XD4 WCM. 050308 | ○ | 28.5 | 25 | 34 | 190 | 112 | 134 | 56 | | | |
| ATUM 29XD4 WCM. 050308 | ● | 29 | 25 | 34 | 194 | 116 | 138 | 56 | | | |
| ATUM 29.5XD4 WCM. 050308 | ○ | 29.5 | 25 | 34 | 194 | 116 | 138 | 56 | | | |

R: Sağ/Right L: Sol/Left ● Stokta/In Stock ○ Stokta Yok/Non Stock Item
ISO Ucuna Uygunudur. / Compatible with ISO Insert.

Sipariş Örneği/Ordering Example : 1 ad./pcs. ATUM 16xD4 WCM. 030208
Takma Uçlu Matkap Kullanım Kılavuzu : S 210 / User's Guide For U-Drills : P 210



Delme Derinliği = 4xÇap
Drilling Depth = 4xDiameter

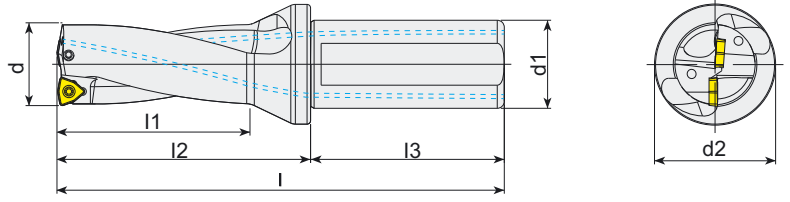

| Takım Kodu Ordering Code | Stok Stock | Takım Ölçüleri (mm) Dimension (mm) | | | | | | | Kesici Uç Insert | Yedek Parçaları Spare Parts | |
|-----------------------------|---------------|---------------------------------------|----------------|----------------|-----|----------------|----------------|----------------|---------------------|--------------------------------|--------------------------|
| | | d | d ₁ | d ₂ | l | l ₁ | l ₂ | l ₃ | | Sıkma Vidası Screw | Tork Anahtar Torx Key |
| ATUM 30XD4 WCM. 06T308 | ● | 30 | 32 | 44 | 207 | 120 | 147 | 60 | WCM. 06T308 | 1510-M3.5x9 | 80-T10 |
| ATUM 31XD4 WCM. 06T308 | ● | 31 | 32 | 44 | 211 | 124 | 151 | 60 | | | |
| ATUM 32XD4 WCM. 06T308 | ● | 32 | 32 | 44 | 215 | 128 | 155 | 60 | | | |
| ATUM 33XD4 WCM. 06T308 | ● | 33 | 32 | 44 | 219 | 132 | 159 | 60 | | | |
| ATUM 33.5XD4 WCM. 06T308 | ● | 33.5 | 32 | 44 | 219 | 132 | 159 | 60 | | | |
| ATUM 34XD4 WCM. 06T308 | ● | 34 | 32 | 44 | 223 | 136 | 163 | 60 | | | |
| ATUM 35XD4 WCM. 06T308 | ● | 35 | 32 | 44 | 227 | 140 | 167 | 60 | | | |
| ATUM 36XD4 WCM. 06T308 | ● | 36 | 32 | 44 | 231 | 144 | 171 | 60 | | | |
| ATUM 37XD4 WCM. 06T308 | ● | 37 | 32 | 44 | 235 | 148 | 175 | 60 | | | |
| ATUM 38XD4 WCM. 06T308 | ● | 38 | 32 | 44 | 239 | 152 | 179 | 60 | | | |
| ATUM 38.5XD4 WCM. 06T308 | ● | 38.5 | 32 | 44 | 239 | 152 | 179 | 60 | | | |
| ATUM 39XD4 WCM. 06T308 | ● | 39 | 32 | 44 | 243 | 156 | 183 | 60 | | | |
| ATUM 40XD4 WCM. 06T308 | ● | 40 | 32 | 44 | 247 | 160 | 187 | 60 | | | |
| ATUM 41XD4 WCM. 06T308 | ● | 41 | 32 | 44 | 251 | 164 | 191 | 60 | | | |
| ATUM 42XD4 WCM. 06T308 | ● | 42 | 32 | 44 | 255 | 168 | 195 | 60 | | | |
| ATUM 43XD4 WCM. 06T308 | ● | 43 | 32 | 44 | 259 | 172 | 199 | 60 | | | |
| ATUM 44XD4 WCM. 06T308 | ● | 44 | 32 | 44 | 263 | 176 | 203 | 60 | | | |
| ATUM 45XD4 WCM. 080412 | ● | 45 | 40 | 54 | 282 | 180 | 212 | 70 | WCM. 080412 | 1515-M4x11 | 80-T15 |
| ATUM 46XD4 WCM. 080412 | ● | 46 | 40 | 54 | 286 | 184 | 216 | 70 | | | |
| ATUM 47XD4 WCM. 080412 | ● | 47 | 40 | 54 | 290 | 188 | 220 | 70 | | | |
| ATUM 48XD4 WCM. 080412 | ● | 48 | 40 | 54 | 294 | 192 | 224 | 70 | | | |
| ATUM 49XD4 WCM. 080412 | ● | 49 | 40 | 54 | 298 | 196 | 228 | 70 | | | |
| ATUM 50XD4 WCM. 080412 | ● | 50 | 40 | 54 | 302 | 200 | 232 | 70 | | | |

R: Sağ/Right L: Sol/Left ● Stokta/In Stock ○ Stokta Yok/Non Stock Item
ISO Ucuna Uygundur. / Compatible with ISO Insert.

Sipariş Örneği/Ordering Example : 1 ad./pcs. ATUM 30x4 WCM. 06T308
Takma Uçlu Matkap Kullanım Kılavuzu : S 210 / User's Guide For U-Drills : P 210





Delme Derinliği = 2xÇap
Drilling Depth = 2xDiameter

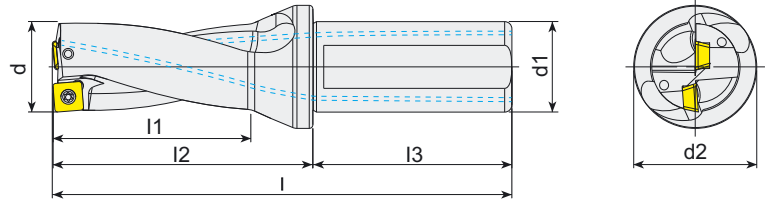

| Takım Kodu Ordering Code | Stok Stock | Takım Ölçüleri (mm) Dimension (mm) | | | | | | | Kesici Uç Insert | Yedek Parçaları Spare Parts | |
|-----------------------------|---------------|---------------------------------------|----------------|----------------|-----|----------------|----------------|----------------|---------------------|--------------------------------|--------------------------|
| | | d | d ₁ | d ₂ | l | l ₁ | l ₂ | l ₃ | | Sıkma Vidası Screw | Tork Anahtar Torx Key |
| ATUM 13XD2 SPMT 050203 | ● | 13 | 20 | 25 | 98 | 26 | 48 | 50 | SPMT 050203 | 3006-M2x4 | 80-T06 |
| ATUM 13.5XD2 SPMT 050203 | ● | 13.5 | 20 | 25 | 98 | 26 | 48 | 50 | | | |
| ATUM 14XD2 SPMT 050203 | ● | 14 | 20 | 25 | 100 | 28 | 50 | 50 | | | |
| ATUM 14.5XD2 SPMT 050203 | ○ | 14.5 | 20 | 25 | 100 | 28 | 50 | 50 | | | |
| ATUM 15XD2 SPMT 050203 | ○ | 15 | 20 | 25 | 102 | 30 | 52 | 50 | | | |
| ATUM 15.5XD2 SPMT 050203 | ○ | 15.5 | 20 | 25 | 102 | 30 | 52 | 50 | SPMT 060204 | 3007-M2.2x5 | 80-T07 |
| ATUM 16XD2 SPMT 060204 | ○ | 16 | 25 | 34 | 110 | 32 | 54 | 56 | | | |
| ATUM 16.5XD2 SPMT 060204 | ○ | 16.5 | 25 | 34 | 110 | 32 | 54 | 56 | | | |
| ATUM 17XD2 SPMT 060204 | ○ | 17 | 25 | 34 | 112 | 34 | 56 | 56 | | | |
| ATUM 17.5XD2 SPMT 060204 | ● | 17.5 | 25 | 34 | 112 | 34 | 56 | 56 | | | |
| ATUM 18XD2 SPMT 060204 | ● | 18 | 25 | 34 | 114 | 36 | 58 | 56 | | | |
| ATUM 18.5D2 SPMT 060204 | ○ | 18.5 | 25 | 34 | 114 | 36 | 58 | 56 | | | |
| ATUM 19XD2 SPMT 060204 | ○ | 19 | 25 | 34 | 116 | 38 | 60 | 56 | | | |
| ATUM 19.5XD2 SPMT 060204 | ● | 19.5 | 25 | 34 | 116 | 38 | 60 | 56 | | | |
| ATUM 20XD2 SPMT 060204 | ● | 20 | 25 | 34 | 118 | 40 | 62 | 56 | | | |
| ATUM 20.5XD2 SPMT 060204 | ○ | 20.5 | 25 | 34 | 118 | 40 | 62 | 56 | SPMT 070204 | 3008-M2.5x6 | 80-T08 |
| ATUM 21XD2 SPMT 060204 | ● | 21 | 25 | 34 | 120 | 42 | 64 | 56 | | | |
| ATUM 21.5XD2 SPMT 060204 | ● | 21.5 | 25 | 34 | 120 | 42 | 64 | 56 | | | |
| ATUM 22XD2 SPMT 070204 | ○ | 22 | 25 | 34 | 122 | 44 | 66 | 56 | | | |
| ATUM 22.5XD2 SPMT 070204 | ○ | 22.5 | 25 | 34 | 122 | 44 | 66 | 56 | | | |
| ATUM 23XD2 SPMT 070204 | ○ | 23 | 25 | 34 | 124 | 46 | 68 | 56 | | | |
| ATUM 23.5XD2 SPMT 070204 | ○ | 23.5 | 25 | 34 | 124 | 46 | 68 | 56 | | | |
| ATUM 24XD2 SPMT 070204 | ○ | 24 | 25 | 34 | 126 | 48 | 70 | 56 | | | |
| ATUM 24.5XD2 SPMT 070204 | ○ | 24.5 | 25 | 34 | 126 | 48 | 70 | 56 | | | |
| ATUM 25XD2 SPMT 070204 | ○ | 25 | 25 | 34 | 128 | 50 | 72 | 56 | | | |

R: Sağ/Right L: Sol/Left ● Stokta/In Stock ○ Stokta Yok/Non Stock Item
KRLY - JD Ucuna Uygunudur. / Compatiple with KRLY - JD Insert.

Sipariş Örneği/Ordering Example : 1 ad./pcs. ATUM 13xD2 SPMT 050203
Takma Uçlu Matkap Kullanım Kılavuzu : S 210 / User's Guide For U-Drills : P 210



Delme Derinliği = 3xÇap
= 4xÇap
Drilling Depth = 3xDiameter
= 4xDiameter

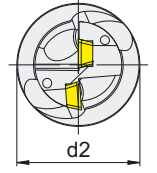
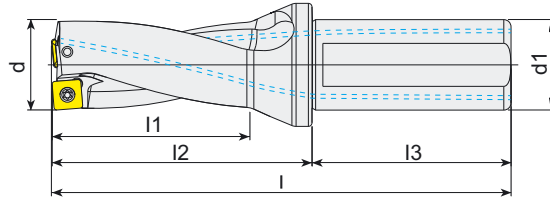

| Takım Kodu Ordering Code | Stok Stock | Takım Ölçüleri (mm) Dimension (mm) | | | | | | | Kesici Uç Insert | Yedek Parçaları Spare Parts | |
|-----------------------------|---------------|---------------------------------------|----|----|-----|-----|-----|----|---------------------|--------------------------------|--------------------------|
| | | d | d1 | d2 | l | l1 | l2 | l3 | | Sıkma Vidası Screw | Tork Anahtar Torx Key |
| ATUM 13XD3 SPMT 050203 | ● | 13 | 20 | 25 | 111 | 39 | 61 | 50 | SPMT 050203 | 3006-M2x4 | 80-T06 |
| ATUM 13.5XD3 SPMT 050203 | ● | 13.5 | 20 | 25 | 111 | 39 | 61 | 50 | | | |
| ATUM 14XD3 SPMT 050203 | ● | 14 | 20 | 25 | 114 | 42 | 64 | 50 | | | |
| ATUM 14.5XD3 SPMT 050203 | ● | 14.5 | 20 | 25 | 114 | 42 | 64 | 50 | | | |
| ATUM 15XD3 SPMT 050203 | ● | 15 | 20 | 25 | 117 | 45 | 67 | 50 | | | |
| ATUM 15.5XD3 SPMT 050203 | ● | 15.5 | 20 | 25 | 117 | 45 | 67 | 50 | | | |
| ATUM 16XD3 SPMT 060204 | ● | 16 | 25 | 34 | 126 | 48 | 70 | 56 | SPMT 060204 | 3007-M2.2x5 | 80-T07 |
| ATUM 16.5XD3 SPMT 060204 | ● | 16.5 | 25 | 34 | 126 | 48 | 70 | 56 | | | |
| ATUM 17XD3 SPMT 060204 | ● | 17 | 25 | 34 | 129 | 51 | 73 | 56 | | | |
| ATUM 17.5XD3 SPMT 060204 | ● | 17.5 | 25 | 34 | 129 | 51 | 73 | 56 | | | |
| ATUM 18XD3 SPMT 060204 | ● | 18 | 25 | 34 | 132 | 54 | 76 | 56 | | | |
| ATUM 18.5XD3 SPMT 060204 | ● | 18.5 | 25 | 34 | 132 | 54 | 76 | 56 | | | |
| ATUM 19XD3 SPMT 060204 | ● | 19 | 25 | 34 | 135 | 57 | 79 | 56 | | | |
| ATUM 19.5XD3 SPMT 060204 | ● | 19.5 | 25 | 34 | 135 | 57 | 79 | 56 | | | |
| ATUM 20XD3 SPMT 060204 | ● | 20 | 25 | 34 | 138 | 60 | 82 | 56 | | | |
| ATUM 20.5XD3 SPMT 060204 | ● | 20.5 | 25 | 34 | 138 | 60 | 82 | 56 | | | |
| ATUM 21XD3 SPMT 060204 | ● | 21 | 25 | 34 | 141 | 63 | 85 | 56 | | | |
| ATUM 21.5XD3 SPMT 060204 | ● | 21.5 | 25 | 34 | 141 | 63 | 85 | 56 | | | |
| ATUM 22XD3 SPMT 070204 | ● | 22 | 25 | 34 | 144 | 66 | 88 | 56 | SPMT 070204 | 3008-M2.5x6 | 80-T08 |
| ATUM 22.5XD3 SPMT 070204 | ● | 22.5 | 25 | 34 | 144 | 66 | 88 | 56 | | | |
| ATUM 23XD3 SPMT 070204 | ● | 23 | 25 | 34 | 147 | 69 | 91 | 56 | | | |
| ATUM 23.5XD3 SPMT 070204 | ● | 23.5 | 25 | 34 | 147 | 69 | 91 | 56 | | | |
| ATUM 24XD3 SPMT 070204 | ● | 24 | 25 | 34 | 150 | 72 | 94 | 56 | | | |
| ATUM 24.5XD3 SPMT 070204 | ● | 24.5 | 25 | 34 | 150 | 72 | 94 | 56 | | | |
| ATUM 25XD3 SPMT 070204 | ● | 25 | 25 | 34 | 153 | 75 | 97 | 56 | | | |
| ATUM 13XD4 SPMT 050203 | ● | 13 | 20 | 25 | 124 | 52 | 74 | 50 | SPMT 050203 | 3006-M2x4 | 80-T06 |
| ATUM 14XD4 SPMT 050203 | ● | 14 | 20 | 25 | 128 | 56 | 78 | 50 | | | |
| ATUM 15XD4 SPMT 050203 | ● | 15 | 20 | 25 | 132 | 60 | 82 | 50 | | | |
| ATUM 16XD4 SPMT 060204 | ● | 16 | 25 | 34 | 142 | 64 | 86 | 56 | SPMT 060204 | 3007-M2.2x5 | 80-T07 |
| ATUM 17XD4 SPMT 060204 | ● | 17 | 25 | 34 | 146 | 68 | 90 | 56 | | | |
| ATUM 18XD4 SPMT 060204 | ● | 18 | 25 | 34 | 150 | 72 | 94 | 56 | | | |
| ATUM 19XD4 SPMT 060204 | ● | 19 | 25 | 34 | 154 | 76 | 98 | 56 | | | |
| ATUM 20XD4 SPMT 060204 | ● | 20 | 25 | 34 | 158 | 80 | 102 | 56 | | | |
| ATUM 21XD4 SPMT 060204 | ● | 21 | 25 | 34 | 162 | 84 | 106 | 56 | | | |
| ATUM 22XD4 SPMT 070204 | ● | 22 | 25 | 34 | 166 | 88 | 110 | 56 | SPMT 070204 | 3008-M2.5x6 | 80-T08 |
| ATUM 23XD4 SPMT 070204 | ● | 23 | 25 | 34 | 170 | 92 | 114 | 56 | | | |
| ATUM 24XD4 SPMT 070204 | ● | 24 | 25 | 34 | 174 | 96 | 118 | 56 | | | |
| ATUM 25XD4 SPMT 070204 | ● | 25 | 25 | 34 | 178 | 100 | 122 | 56 | | | |

R: Sağ/Right L: Sol/Left ● Stokta/In Stock ○ Stokta Yok/Non Stock Item
KRLY - JD Ucuna Uygunur. / Compatiple with KRLY - JD Insert.

Sipariş Örneği/Ordering Example : 1 ad./pcs. ATUM 13x3 SPMT 050203
Takma Uçlu Matkap Kullanım Kılavuzu : S 210 / User's Guide For U-Drills : P 210



Delme Derinliği = 2xÇap
Drilling Depth = 2xDiameter

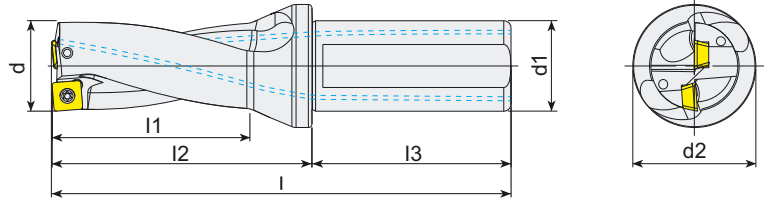

| Takım Kodu Ordering Code | Stok Stock | Takım Ölçüleri (mm) Dimension (mm) | | | | | | | Kesici Uç Insert | Yedek Parçaları Spare Parts | |
|-----------------------------|---------------|---------------------------------------|----|----|-----|----|----|----|---------------------|--------------------------------|--------------------------|
| | | d | d1 | d2 | l | l1 | l2 | l3 | | Sıkma Vidası Screw | Tork Anahtar Torx Key |
| ATUM 12.5XD2 SP.. 050204 | ● | 12.5 | 20 | 25 | 96 | 24 | 46 | 50 | SP. 050204 | 3006-M2x4 | 80-T06 |
| ATUM 13XD2 SP.. 050204 | ● | 13 | 20 | 25 | 98 | 26 | 48 | 50 | | | |
| ATUM 13.5XD2 SP.. 050204 | ● | 13.5 | 20 | 25 | 98 | 26 | 48 | 50 | | | |
| ATUM 14XD2 SP.. 050204 | ● | 14 | 20 | 25 | 100 | 28 | 50 | 50 | | | |
| ATUM 14.5XD2 SP.. 050204 | ● | 14.5 | 20 | 25 | 100 | 28 | 50 | 50 | | | |
| ATUM 15XD2 SP.. 050204 | ● | 15 | 20 | 25 | 102 | 30 | 52 | 50 | SP. 060204 | 3007-M2.2x5 | 80-T07 |
| ATUM 15.5XD2 SP.. 060204 | ● | 15.5 | 20 | 25 | 102 | 30 | 52 | 50 | | | |
| ATUM 16XD2 SP.. 060204 | ● | 16 | 25 | 34 | 110 | 32 | 54 | 56 | | | |
| ATUM 16.5XD2 SP.. 060204 | ● | 16.5 | 25 | 34 | 110 | 32 | 54 | 56 | | | |
| ATUM 17XD2 SP.. 060204 | ● | 17 | 25 | 34 | 112 | 34 | 56 | 56 | | | |
| ATUM 17.5XD2 SP.. 060204 | ● | 17.5 | 25 | 34 | 112 | 34 | 56 | 56 | | | |
| ATUM 18XD2 SP.. 060204 | ● | 18 | 25 | 34 | 114 | 36 | 58 | 56 | | | |
| ATUM 18.5XD2 SP.. 060204 | ● | 18.5 | 25 | 34 | 114 | 36 | 58 | 56 | | | |
| ATUM 19XD2 SP.. 060204 | ● | 19 | 25 | 34 | 116 | 38 | 60 | 56 | | | |
| ATUM 19.5XD2 SP.. 060204 | ● | 19.5 | 25 | 34 | 116 | 38 | 60 | 56 | | | |
| ATUM 20XD2 SP.. 060204 | ● | 20 | 25 | 34 | 118 | 40 | 62 | 56 | SP. 07T308 | 3008-M2.5x6 | 80-T08 |
| ATUM 20.5XD2 SP.. 060204 | ● | 20.5 | 25 | 34 | 118 | 40 | 62 | 56 | | | |
| ATUM 21XD2 SP.. 060204 | ● | 21 | 25 | 34 | 120 | 42 | 64 | 56 | | | |
| ATUM 21.5XD2 SP.. 060204 | ● | 21.5 | 25 | 34 | 120 | 42 | 64 | 56 | | | |
| ATUM 22XD2 SP.. 07T308 | ● | 22 | 25 | 34 | 122 | 44 | 66 | 56 | | | |
| ATUM 22.5XD2 SP.. 07T308 | ● | 22.5 | 25 | 34 | 122 | 44 | 66 | 56 | | | |
| ATUM 23XD2 SP.. 07T308 | ● | 23 | 25 | 34 | 124 | 46 | 68 | 56 | | | |
| ATUM 23.5XD2 SP.. 07T308 | ● | 23.5 | 25 | 34 | 124 | 46 | 68 | 56 | | | |
| ATUM 24XD2 SP.. 07T308 | ● | 24 | 25 | 34 | 126 | 48 | 70 | 56 | | | |
| ATUM 24.5XD2 SP.. 07T308 | ● | 24.5 | 25 | 34 | 126 | 48 | 70 | 56 | | | |
| ATUM 25XD2 SP.. 07T308 | ● | 25 | 25 | 34 | 128 | 50 | 72 | 56 | | | |
| ATUM 25.5XD2 SP.. 07T308 | ● | 25.5 | 25 | 34 | 128 | 50 | 72 | 56 | | | |
| ATUM 26XD2 SP.. 07T308 | ● | 26 | 25 | 34 | 130 | 52 | 74 | 56 | | | |
| ATUM 26.5XD2 SP.. 07T308 | ● | 26.5 | 25 | 34 | 130 | 52 | 74 | 56 | | | |
| ATUM 27XD2 SP.. 07T308 | ● | 27 | 25 | 34 | 132 | 54 | 76 | 56 | | | |
| ATUM 27.5XD2 SP.. 07T308 | ● | 27.5 | 25 | 34 | 132 | 54 | 76 | 56 | | | |

R: Sağ/Right L: Sol/Left ● Stokta/In Stock ○ Stokta Yok/Non Stock Item
TGTC Ucuna Uygundur. / Compatible with TGTC Insert.

Sipariş Örneği/Ordering Example : 1 ad./pcs. ATUM 12.5XD2 SP.. 050204
Takma Uçlu Matkap Kullanım Kılavuzu : S 210 / User's Guide For U-Drills : P 210



Delme Derinliği = 2xÇap
Drilling Depth = 2xDiameter

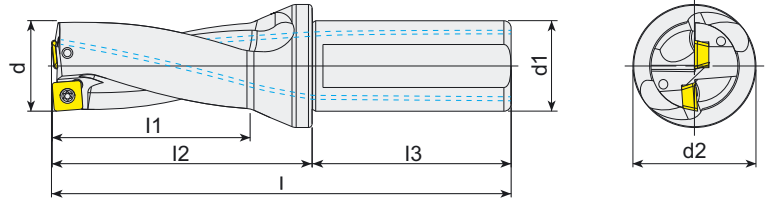

| Takım Kodu Ordering Code | Stok Stock | Takım Ölçüleri (mm) Dimension (mm) | | | | | | | Kesici Uç Insert | Yedek Parçaları Spare Parts | |
|-----------------------------|---------------|---------------------------------------|----------------|----------------|-----|----------------|----------------|----------------|---------------------|--------------------------------|--------------------------|
| | | d | d ₁ | d ₂ | l | l ₁ | l ₂ | l ₃ | | Sıkma Vidası Screw | Tork Anahtar Torx Key |
| ATUM 28XD2 SP. 090408 | ● | 28 | 25 | 34 | 134 | 56 | 78 | 56 | SP. 090408 | 4015-M3.5x9 | 80-T15 |
| ATUM 28.5XD2 SP. 090408 | ● | 28.5 | 25 | 34 | 134 | 56 | 78 | 56 | | | |
| ATUM 29XD2 SP. 090408 | ● | 29 | 25 | 34 | 136 | 58 | 80 | 56 | | | |
| ATUM 29.5XD2 SP. 090408 | ● | 29.5 | 25 | 34 | 136 | 58 | 80 | 56 | | | |
| ATUM 30XD2 SP. 090408 | ● | 30 | 32 | 44 | 147 | 60 | 87 | 60 | | | |
| ATUM 31XD2 SP. 090408 | ● | 31 | 32 | 44 | 149 | 62 | 89 | 60 | | | |
| ATUM 32XD2 SP. 090408 | ● | 32 | 32 | 44 | 151 | 64 | 91 | 60 | | | |
| ATUM 33XD2 SP. 090408 | ● | 33 | 32 | 44 | 153 | 66 | 93 | 60 | | | |
| ATUM 34XD2 SP. 110408 | ● | 34 | 32 | 44 | 155 | 68 | 95 | 60 | SP. 110408 | 1515-M4x11 | 80-T15 |
| ATUM 35XD2 SP. 110408 | ● | 35 | 32 | 44 | 157 | 70 | 97 | 60 | | | |
| ATUM 36XD2 SP. 110408 | ● | 36 | 32 | 44 | 159 | 72 | 99 | 60 | | | |
| ATUM 37XD2 SP. 110408 | ○ | 37 | 32 | 44 | 161 | 74 | 101 | 60 | | | |
| ATUM 38XD2 SP. 110408 | ● | 38 | 32 | 44 | 163 | 76 | 103 | 60 | | | |
| ATUM 39XD2 SP. 110408 | ● | 39 | 32 | 44 | 165 | 78 | 105 | 60 | | | |
| ATUM 40XD2 SP. 110408 | ● | 40 | 32 | 44 | 167 | 80 | 107 | 60 | | | |
| ATUM 41XD2 SP. 110408 | ○ | 41 | 32 | 44 | 169 | 82 | 109 | 60 | | | |
| ATUM 42XD2 SP. 140512 | ● | 42 | 32 | 44 | 171 | 84 | 111 | 60 | SP. 140512 | 1020-M5x11 | 80-T20 |
| ATUM 43XD2 SP. 140512 | ● | 43 | 32 | 44 | 173 | 86 | 113 | 60 | | | |
| ATUM 44XD2 SP. 140512 | ● | 44 | 32 | 44 | 175 | 88 | 115 | 60 | | | |
| ATUM 45XD2 SP. 140512 | ○ | 45 | 40 | 54 | 192 | 90 | 122 | 70 | | | |
| ATUM 46XD2 SP. 140512 | ○ | 46 | 40 | 54 | 194 | 92 | 124 | 70 | | | |
| ATUM 47XD2 SP. 140512 | ○ | 47 | 40 | 54 | 196 | 94 | 126 | 70 | | | |
| ATUM 48XD2 SP. 140512 | ● | 48 | 40 | 54 | 198 | 96 | 128 | 70 | | | |
| ATUM 49XD2 SP. 140512 | ● | 49 | 40 | 54 | 200 | 98 | 130 | 70 | | | |
| ATUM 50XD2 SP. 140512 | ○ | 50 | 40 | 54 | 202 | 100 | 132 | 70 | | | |

R: Sağ/Right L: Sol/Left ● Stokta/In Stock ○ Stokta Yok/Non Stock Item
TGTC Ucuna Uygunudur. / Compatible with TGTC Insert.

Sipariş Örneği/Ordering Example : 1 ad./pcs. ATUM 28xD2 SP. 090408
Takma Uçlu Matkap Kullanım Kılavuzu : S 210 / User's Guide For U-Drills : P 210



Delme Derinliği = 3xÇap
Drilling Depth = 3xDiameter

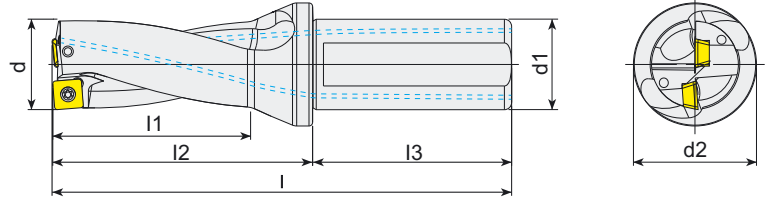

| Takım Kodu Ordering Code | Stok Stock | Takım Ölçüleri (mm) Dimension (mm) | | | | | | | Kesici Uç Insert | Yedek Parçaları Spare Parts | | | | |
|-----------------------------|---------------|---------------------------------------|----|----|-----|----|-----|----|---------------------|--------------------------------|--------------------------|------------|-------------|--------|
| | | d | d1 | d2 | l | l1 | l2 | l3 | | Sıkma Vidası Screw | Tork Anahtar Torx Key | | | |
| ATUM 12.5XD3 SP. 050204 | ● | 12.5 | 20 | 25 | 108 | 36 | 58 | 50 | SP. 050204 | 3006-M2x4 | 80-T06 | | | |
| ATUM 13XD3 SP. 050204 | ● | 13 | 20 | 25 | 111 | 39 | 61 | 50 | | | | | | |
| ATUM 13.5XD3 SP. 050204 | ● | 13.5 | 20 | 25 | 111 | 39 | 61 | 50 | | | | | | |
| ATUM 14XD3 SP. 050204 | ● | 14 | 20 | 25 | 114 | 42 | 64 | 50 | | | | | | |
| ATUM 14.5XD3 SP. 050204 | ● | 14.5 | 20 | 25 | 114 | 42 | 64 | 50 | | | | | | |
| ATUM 15XD3 SP. 050204 | ● | 15 | 20 | 25 | 117 | 45 | 67 | 50 | | | | | | |
| ATUM 15.5XD3 SP. 060204 | ● | 15.5 | 20 | 25 | 117 | 45 | 67 | 50 | | | | SP. 060204 | 3007-M2.2x5 | 80-T07 |
| ATUM 16XD3 SP. 060204 | ● | 16 | 25 | 34 | 126 | 48 | 70 | 56 | | | | | | |
| ATUM 16.5XD3 SP. 060204 | ● | 16.5 | 25 | 34 | 126 | 48 | 70 | 56 | | | | | | |
| ATUM 17XD3 SP. 060204 | ● | 17 | 25 | 34 | 129 | 51 | 73 | 56 | | | | | | |
| ATUM 17.5XD3 SP. 060204 | ● | 17.5 | 25 | 34 | 129 | 51 | 73 | 56 | | | | | | |
| ATUM 18XD3 SP. 060204 | ● | 18 | 25 | 34 | 132 | 54 | 76 | 56 | | | | | | |
| ATUM 18.5XD3 SP. 060204 | ● | 18.5 | 25 | 34 | 132 | 54 | 76 | 56 | | | | | | |
| ATUM 19XD3 SP. 060204 | ● | 19 | 25 | 34 | 135 | 57 | 79 | 56 | | | | | | |
| ATUM 19.5XD3 SP. 060204 | ● | 19.5 | 25 | 34 | 135 | 57 | 79 | 56 | | | | | | |
| ATUM 20XD3 SP. 060204 | ● | 20 | 25 | 34 | 138 | 60 | 82 | 56 | SP. 07T308 | 3008-M2.5x6 | 80-T08 | | | |
| ATUM 20.5XD3 SP. 060204 | ● | 20.5 | 25 | 34 | 138 | 60 | 82 | 56 | | | | | | |
| ATUM 21XD3 SP. 060204 | ● | 21 | 25 | 34 | 141 | 63 | 85 | 56 | | | | | | |
| ATUM 21.5XD3 SP. 060204 | ● | 21.5 | 25 | 34 | 141 | 63 | 85 | 56 | | | | | | |
| ATUM 22XD3 SP. 07T308 | ● | 22 | 25 | 34 | 144 | 66 | 88 | 56 | | | | | | |
| ATUM 22.5XD3 SP. 07T308 | ● | 22.5 | 25 | 34 | 144 | 66 | 88 | 56 | | | | | | |
| ATUM 23XD3 SP. 07T308 | ● | 23 | 25 | 34 | 147 | 69 | 91 | 56 | | | | | | |
| ATUM 23.5XD3 SP. 07T308 | ● | 23.5 | 25 | 34 | 147 | 69 | 91 | 56 | | | | | | |
| ATUM 24XD3 SP. 07T308 | ● | 24 | 25 | 34 | 150 | 72 | 94 | 56 | | | | | | |
| ATUM 24.5XD3 SP. 07T308 | ● | 24.5 | 25 | 34 | 150 | 72 | 94 | 56 | | | | | | |
| ATUM 25XD3 SP. 07T308 | ● | 25 | 25 | 34 | 153 | 75 | 97 | 56 | SP. 090408 | 4015-M3.5x9 | 80-T15 | | | |
| ATUM 25.5XD3 SP. 07T308 | ● | 25.5 | 25 | 34 | 153 | 75 | 97 | 56 | | | | | | |
| ATUM 26XD3 SP. 07T308 | ● | 26 | 25 | 34 | 156 | 78 | 100 | 56 | | | | | | |
| ATUM 26.5XD3 SP. 07T308 | ● | 26.5 | 25 | 34 | 156 | 78 | 100 | 56 | | | | | | |
| ATUM 27XD3 SP. 07T308 | ● | 27 | 25 | 34 | 159 | 81 | 103 | 56 | | | | | | |
| ATUM 27.5XD3 SP. 07T308 | ● | 27.5 | 25 | 34 | 159 | 81 | 103 | 56 | | | | | | |
| ATUM 28XD3 SP. 090408 | ● | 28 | 25 | 34 | 162 | 84 | 106 | 56 | | | | | | |
| ATUM 28.5XD3 SP. 090408 | ● | 28.5 | 25 | 34 | 162 | 84 | 106 | 56 | | | | | | |
| ATUM 29XD3 SP. 090408 | ● | 29 | 25 | 34 | 165 | 87 | 109 | 56 | | | | | | |
| ATUM 29.5XD3 SP. 090408 | ● | 29.5 | 25 | 34 | 165 | 87 | 109 | 56 | | | | | | |
| ATUM 30XD3 SP. 090408 | ● | 30 | 32 | 44 | 177 | 90 | 117 | 60 | | | | | | |
| ATUM 30.5XD3 SP. 090408 | ● | 30.5 | 32 | 44 | 177 | 90 | 117 | 60 | | | | | | |
| ATUM 31XD3 SP. 090408 | ● | 31 | 32 | 44 | 180 | 93 | 120 | 60 | | | | | | |
| ATUM 31.5XD3 SP. 090408 | ● | 31.5 | 32 | 44 | 180 | 93 | 120 | 60 | | | | | | |
| ATUM 32XD3 SP. 090408 | ● | 32 | 32 | 44 | 183 | 96 | 123 | 60 | | | | | | |
| ATUM 32.5XD3 SP. 090408 | ● | 32.5 | 32 | 44 | 183 | 96 | 123 | 60 | | | | | | |
| ATUM 33XD3 SP. 090408 | ● | 33 | 32 | 44 | 186 | 99 | 126 | 60 | | | | | | |
| ATUM 33.5XD3 SP. 090408 | ● | 33.5 | 32 | 44 | 186 | 99 | 126 | 60 | | | | | | |

R: Sağ/Right L: Sol/Left ● Stokta/In Stock ○ Stokta Yok/Non Stock Item
TGTC Ucuna Uygunudur. / Compatible with TGTC Insert.

Sipariş Örneği/Ordering Example : 1 ad./pcs. ATUM 12.5xD3 SP. 050204
Takma Uçlu Matkap Kullanım Kılavuzu : S 210 / User's Guide For U-Drills : P 210

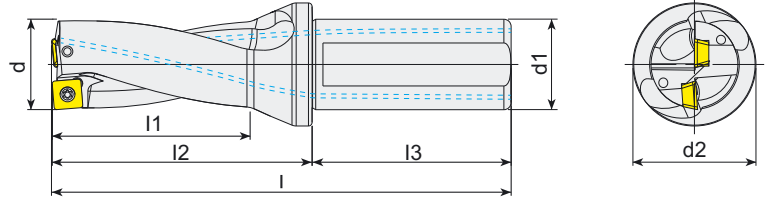

Delme Derinliği = 3xÇap
Drilling Depth = 3xDiameter

| Takım Kodu Ordering Code | Stok Stock | Takım Ölçüleri (mm) Dimension (mm) | | | | | | | Kesici Uç Insert | Yedek Parçaları Spare Parts | | | | |
|-----------------------------|---------------|---------------------------------------|----------------|----------------|-----|----------------|----------------|----------------|---------------------|--------------------------------|--------------------------|------------|------------|--------|
| | | d | d ₁ | d ₂ | l | l ₁ | l ₂ | l ₃ | | Sıkma Vidası Screw | Tork Anahtar Torx Key | | | |
| ATUM 34XD3 SP. 110408 | ● | 34 | 32 | 44 | 189 | 102 | 129 | 60 | SP. 110408 | 1515-M4x11 | 80-T15 | | | |
| ATUM 34.5XD3 SP. 110408 | ● | 34.5 | 32 | 44 | 189 | 102 | 129 | 60 | | | | | | |
| ATUM 35XD3 SP. 110408 | ● | 35 | 32 | 44 | 192 | 105 | 132 | 60 | | | | | | |
| ATUM 35.5XD3 SP. 110408 | ● | 35.5 | 32 | 44 | 192 | 105 | 132 | 60 | | | | | | |
| ATUM 36XD3 SP. 110408 | ● | 36 | 32 | 44 | 195 | 108 | 135 | 60 | | | | | | |
| ATUM 36.5XD3 SP. 110408 | ● | 36.5 | 32 | 44 | 195 | 108 | 135 | 60 | | | | | | |
| ATUM 37XD3 SP. 110408 | ● | 37 | 32 | 44 | 198 | 111 | 138 | 60 | | | | | | |
| ATUM 37.5XD3 SP. 110408 | ● | 37.5 | 32 | 44 | 198 | 111 | 138 | 60 | | | | | | |
| ATUM 38XD3 SP. 110408 | ● | 38 | 32 | 44 | 201 | 114 | 141 | 60 | | | | | | |
| ATUM 38.5XD3 SP. 110408 | ● | 38.5 | 32 | 44 | 201 | 114 | 141 | 60 | | | | | | |
| ATUM 39XD3 SP. 110408 | ● | 39 | 32 | 44 | 204 | 117 | 144 | 60 | | | | | | |
| ATUM 39.5XD3 SP. 110408 | ● | 39.5 | 32 | 44 | 204 | 117 | 144 | 60 | | | | | | |
| ATUM 40XD3 SP. 110408 | ● | 40 | 32 | 44 | 207 | 120 | 147 | 60 | | | | | | |
| ATUM 40.5XD3 SP. 110408 | ● | 40.5 | 32 | 44 | 207 | 120 | 147 | 60 | | | | | | |
| ATUM 41XD3 SP. 110408 | ● | 41 | 32 | 44 | 210 | 123 | 150 | 60 | | | | | | |
| ATUM 41.5XD3 SP. 110408 | ● | 41.5 | 32 | 44 | 210 | 123 | 150 | 60 | | | | | | |
| ATUM 42XD3 SP. 140512 | ● | 42 | 32 | 44 | 213 | 126 | 153 | 60 | | | | SP. 140512 | 1020-M5x11 | 80-T20 |
| ATUM 42.5XD3 SP. 140512 | ● | 42.5 | 32 | 44 | 213 | 126 | 153 | 60 | | | | | | |
| ATUM 43XD3 SP. 140512 | ○ | 43 | 32 | 44 | 216 | 129 | 156 | 60 | | | | | | |
| ATUM 43.5XD3 SP. 140512 | ○ | 43.5 | 32 | 44 | 216 | 129 | 156 | 60 | | | | | | |
| ATUM 44XD3 SP. 140512 | ● | 44 | 32 | 44 | 219 | 132 | 159 | 60 | | | | | | |
| ATUM 44.5XD3 SP. 140512 | ● | 44.5 | 32 | 44 | 219 | 132 | 159 | 60 | | | | | | |
| ATUM 45XD3 SP. 140512 | ● | 45 | 40 | 54 | 237 | 135 | 167 | 70 | | | | | | |
| ATUM 45.5XD3 SP. 140512 | ● | 45.5 | 40 | 54 | 237 | 135 | 167 | 70 | | | | | | |
| ATUM 46XD3 SP. 140512 | ● | 46 | 40 | 54 | 240 | 138 | 170 | 70 | | | | | | |
| ATUM 47XD3 SP. 140512 | ○ | 47 | 40 | 54 | 243 | 141 | 173 | 70 | | | | | | |
| ATUM 48XD3 SP. 140512 | ● | 48 | 40 | 54 | 246 | 144 | 176 | 70 | | | | | | |
| ATUM 49XD3 SP. 140512 | ● | 49 | 40 | 54 | 249 | 147 | 179 | 70 | | | | | | |
| ATUM 50XD3 SP. 140512 | ● | 50 | 40 | 54 | 252 | 150 | 182 | 70 | | | | | | |
| ATUM 51XD3 SP. 140512 | ○ | 51 | 40 | 54 | 255 | 153 | 185 | 70 | | | | | | |
| ATUM 52XD3 SP. 140512 | ○ | 52 | 40 | 54 | 258 | 156 | 188 | 70 | | | | | | |
| ATUM 53XD3 SP. 140512 | ○ | 53 | 40 | 54 | 261 | 159 | 191 | 70 | | | | | | |
| ATUM 54XD3 SP. 140512 | ○ | 54 | 40 | 54 | 264 | 162 | 194 | 70 | | | | | | |
| ATUM 55XD3 SP. 140512 | ○ | 55 | 40 | 54 | 267 | 165 | 197 | 70 | | | | | | |
| ATUM 56XD3 SP. 140512 | ○ | 56 | 40 | 59 | 270 | 168 | 200 | 70 | | | | | | |
| ATUM 57XD3 SP. 140512 | ○ | 57 | 40 | 59 | 273 | 171 | 203 | 70 | | | | | | |
| ATUM 58XD3 SP. 140512 | ○ | 58 | 40 | 59 | 276 | 174 | 206 | 70 | | | | | | |
| ATUM 59XD3 SP. 140512 | ○ | 59 | 40 | 59 | 279 | 177 | 209 | 70 | | | | | | |
| ATUM 60XD3 SP. 140512 | ○ | 60 | 40 | 59 | 282 | 180 | 212 | 70 | | | | | | |

R: Sağ/Right L: Sol/Left ● Stokta/In Stock ○ Stokta Yok/Non Stock Item
TGTC Ucuna Uygundur. / Compatiple with TGTC Insert.

Sipariş Örneği/Ordering Example : 1 ad./pcs. ATUM 34xD3 SP. 110408
Takma Uçlu Matkap Kullanım Kılavuzu : S 210 / User's Guide For U-Drills : P 210



Delme Derinliği = 4xÇap
Drilling Depth = 4xDiameter

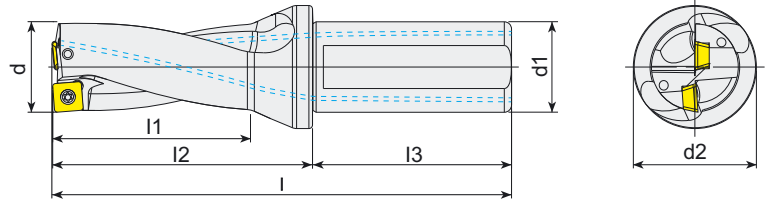

| Takım Kodu Ordering Code | Stok Stock | Takım Ölçüleri (mm) Dimension (mm) | | | | | | | Kesici Uç Insert | Yedek Parçaları Spare Parts | |
|-----------------------------|---------------|---------------------------------------|----|----|-----|-----|-----|----|---------------------|--------------------------------|--------------------------|
| | | d | d1 | d2 | l | l1 | l2 | l3 | | Sıkma Vidası Screw | Tork Anahtar Torx Key |
| ATUM 13XD4 SP. 050204 | ● | 13 | 20 | 25 | 124 | 52 | 74 | 50 | SP. 050204 | 3006-M2x4 | 80-T06 |
| ATUM 14XD4 SP. 050204 | ● | 14 | 20 | 25 | 128 | 56 | 78 | 50 | | | |
| ATUM 15XD4 SP. 050204 | ● | 15 | 20 | 25 | 132 | 60 | 82 | 50 | | | |
| ATUM 16XD4 SP. 060204 | ● | 16 | 25 | 34 | 142 | 64 | 86 | 56 | SP. 060204 | 3007-M2.2x5 | 80-T07 |
| ATUM 17XD4 SP. 060204 | ● | 17 | 25 | 34 | 146 | 68 | 90 | 56 | | | |
| ATUM 17.5XD4 SP. 060204 | ● | 17 | 25 | 34 | 146 | 68 | 90 | 56 | | | |
| ATUM 18XD4 SP. 060204 | ● | 18 | 25 | 34 | 150 | 72 | 94 | 56 | | | |
| ATUM 19XD4 SP. 060204 | ● | 19 | 25 | 34 | 154 | 76 | 98 | 56 | | | |
| ATUM 19.5XD4 SP. 060204 | ● | 19.5 | 25 | 34 | 154 | 76 | 98 | 56 | | | |
| ATUM 20XD4 SP. 060204 | ● | 20 | 25 | 34 | 158 | 80 | 102 | 56 | | | |
| ATUM 21XD4 SP. 060204 | ● | 21 | 25 | 34 | 162 | 84 | 106 | 56 | SP. 07T308 | 3008-M2.5x6 | 80-T08 |
| ATUM 22XD4 SP. 07T308 | ● | 22 | 25 | 34 | 166 | 88 | 110 | 56 | | | |
| ATUM 23XD4 SP. 07T308 | ● | 23 | 25 | 34 | 170 | 92 | 114 | 56 | | | |
| ATUM 23.5XD4 SP. 07T308 | ● | 23.5 | 25 | 34 | 170 | 92 | 114 | 56 | | | |
| ATUM 24XD4 SP. 07T308 | ● | 24 | 25 | 34 | 174 | 96 | 118 | 56 | | | |
| ATUM 25XD4 SP. 07T308 | ● | 25 | 25 | 34 | 178 | 100 | 122 | 56 | | | |
| ATUM 26XD4 SP. 07T308 | ● | 26 | 25 | 34 | 182 | 104 | 126 | 56 | | | |
| ATUM 27XD4 SP. 07T308 | ● | 27 | 25 | 34 | 186 | 108 | 130 | 56 | SP. 090408 | 4015-M3.5x9 | 80-T15 |
| ATUM 27.5XD4 SP. 07T308 | ● | 27.5 | 25 | 34 | 186 | 108 | 130 | 56 | | | |
| ATUM 28XD4 SP. 090408 | ● | 28 | 25 | 34 | 190 | 112 | 134 | 56 | | | |
| ATUM 29XD4 SP. 090408 | ● | 29 | 25 | 34 | 194 | 116 | 138 | 56 | | | |
| ATUM 30XD4 SP. 090408 | ● | 30 | 32 | 44 | 207 | 120 | 147 | 60 | | | |
| ATUM 31XD4 SP. 090408 | ○ | 31 | 32 | 44 | 211 | 124 | 151 | 60 | | | |
| ATUM 32XD4 SP. 090408 | ● | 32 | 32 | 44 | 215 | 128 | 155 | 60 | | | |
| ATUM 33XD4 SP. 090408 | ○ | 33 | 32 | 44 | 219 | 132 | 159 | 60 | SP. 110408 | 1515-M4x11 | 80-T15 |
| ATUM 33.5XD4 SP. 090408 | ● | 33.5 | 32 | 44 | 219 | 132 | 159 | 60 | | | |
| ATUM 34XD4 SP. 110408 | ○ | 34 | 32 | 44 | 223 | 136 | 163 | 60 | | | |
| ATUM 35XD4 SP. 110408 | ○ | 35 | 32 | 44 | 227 | 140 | 167 | 60 | | | |
| ATUM 36XD4 SP. 110408 | ● | 36 | 32 | 44 | 231 | 144 | 171 | 60 | | | |
| ATUM 37XD4 SP. 110408 | ● | 37 | 32 | 44 | 235 | 148 | 175 | 60 | | | |
| ATUM 38XD4 SP. 110408 | ● | 38 | 32 | 44 | 239 | 152 | 179 | 60 | | | |
| ATUM 39XD4 SP. 110408 | ○ | 39 | 32 | 44 | 243 | 156 | 183 | 60 | SP. 140512 | 1020-M5x11 | 80-T20 |
| ATUM 40XD4 SP. 110408 | ○ | 40 | 32 | 44 | 247 | 160 | 187 | 60 | | | |
| ATUM 41XD4 SP. 110408 | ○ | 41 | 32 | 44 | 251 | 164 | 191 | 60 | | | |
| ATUM 42XD4 SP. 140512 | ● | 42 | 32 | 44 | 255 | 168 | 195 | 60 | | | |
| ATUM 43XD4 SP. 140512 | ○ | 43 | 32 | 44 | 259 | 172 | 199 | 60 | | | |
| ATUM 44XD4 SP. 140512 | ○ | 44 | 32 | 44 | 263 | 176 | 203 | 60 | | | |

R: Sağ/Right L: Sol/Left ● Stokta/In Stock ○ Stokta Yok/Non Stock Item
TGTC Ucuna Uygunudur. / Compatible with TGTC Insert.

Sipariş Örneği/Ordering Example : 1 ad./pcs. ATUM 13xD4 SP. 050204
Takma Uçlu Matkap Kullanım Kılavuzu : S 210 / User's Guide For U-Drills : P 210

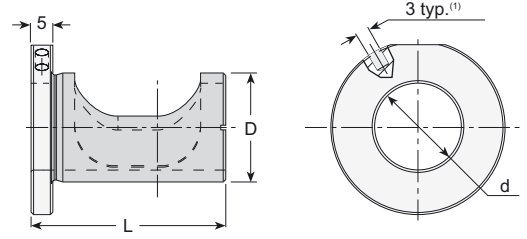

Takım Kodu
Ordering Code

Stok
Stock

Takım Ölçüleri (mm)
Dimension (mm)

| Takım Kodu Ordering Code | Stok Stock | d | D | L |
|-----------------------------|---------------|----|----|----|
| AET-2025 | ● | 20 | 25 | 44 |
| AET-2532 | ● | 25 | 32 | 46 |
| AET-3240 | ● | 32 | 40 | 55 |

■⁽¹⁾ Delik ince bir metal yardımıyla adaptörün radyal olarak ayarlanmasını kolaylaştırmak için kullanılır. / Holes for inserting a pin, used to facilitate radial adjustment of the sleeve (pin not supplied).

Frezeleme tezgahında takma uçlu matkabın nominal çapı, matkabın ekseninin, spindle eksenine göre ötelenmesiyle değiştirilebilir.

On a milling machine the drill's nominal diameter can be changed by shifting the drill's axis out of the tool spindle.

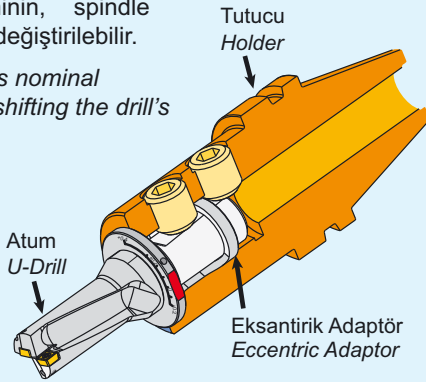

Radyal ayarlama pimi.
(Verilmeyecektir.)

Radial adjustment
pin. (not supplied)

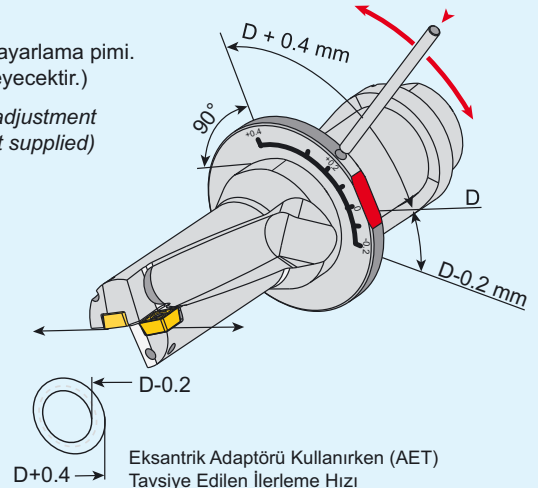

Eksantrik Adaptörü Kullanırken (AET)
Tavsiye Edilen İlerleme Hızı
Recommended Feed When Using Eccentric Adaptor

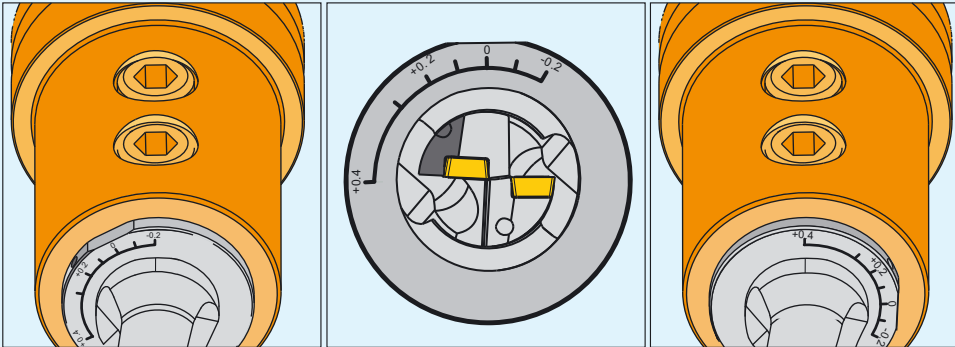
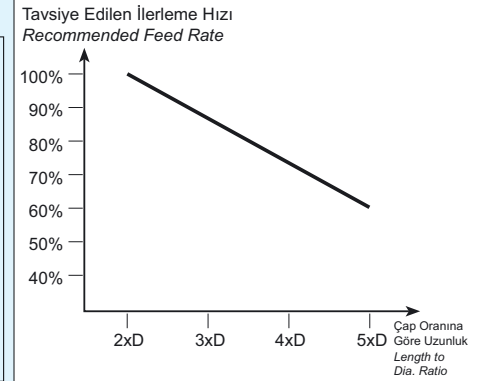

Delik Çapı
24.8 mm
Hole Diameter

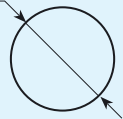

U-Drill Çapı = 25 mm
Drill Diameter = 25 mm

Delik Çapı
25 mm
Hole Diameter

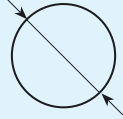

U-Drill Çapı = 25 mm
Drill Diameter = 25 mm

Delik Çapı
25.4 mm
Hole Diameter

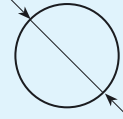

U-Drill Çapı = 25 mm
Drill Diameter = 25 mm

ATUM'un üzerindeki düz çizgi adaptörün sıfır rakamının üzerine konulmalıdır. AET'nin (eksantrik adaptörün) çevrilmesini kolaylaştırmak için AET'nin üzerindeki deliğe, metal bir çubuk ya da vida anahtarı yerleştirilebilir. AET'yi ayarlamadan önce tutucunun vidasını hafifçe çözün.

The adjustment markings should be located perpendicular to the flat on the circumference of the U-DRILL flange.

To facilitate the rotation of the adaptor, a metal rod or a screw key may be inserted into a hole on the eccentric adaptor flange. Unlock adapter screw before adjusting adaptor.



*konusulan
the spoken kalite...
quality...*

EKONOMİK KESİCİLER

EKONOMİK KESİCİLER
ECONOMIC CUTTING TOOLS





AKKO

A

1

EK

2

R

3

D2.25

4

x 20

5

X

6

C

7

■

8

■

9

10

10

T3

11

04

12

2 Kesiş Stili / Cutter Style

EK : Ekonomik Kesici / Economic Cutting

3 Kesme Yönü / Cutting Direction

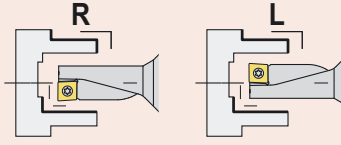

11 Kalınlık / Thickness

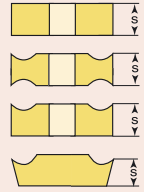

| | |
|----|----------|
| 01 | s = 1.59 |
| T1 | s = 1.98 |
| 02 | s = 2.38 |
| T2 | s = 2.78 |
| 03 | s = 3.18 |
| T3 | s = 3.97 |
| 04 | s = 4.76 |
| 05 | s = 5.56 |
| 06 | s = 6.35 |
| 07 | s = 7.94 |
| 09 | s = 9.52 |

4 Delme Derinliği / Drilling Depth

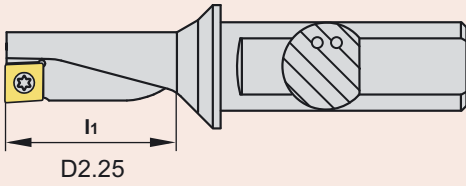

5 Takım Çapı / Tool Diameter

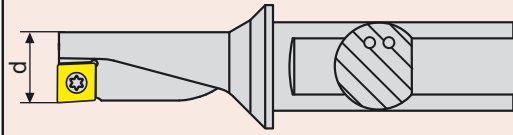

6 Uç Şekli / Insert Form



X



Q

7 Serbest Uç Açısı / Clearance Angle of Insert

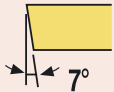

C

8 Toleranslar / Tolerance Classes



| | d | m | t |
|---|-------------|-------------|---------|
| A | ± 0.025 | ± 0.005 | ± 0.025 |
| C | ± 0.025 | ± 0.013 | ± 0.025 |
| E | ± 0.025 | ± 0.025 | ± 0.025 |
| F | ± 0.013 | ± 0.005 | ± 0.025 |
| G | ± 0.025 | ± 0.025 | ± 0.130 |
| H | ± 0.013 | ± 0.013 | ± 0.025 |
| J | ± 0.05-0.15 | ± 0.005 | ± 0.025 |
| K | ± 0.05-0.15 | ± 0.013 | ± 0.025 |
| L | ± 0.05-0.15 | ± 0.025 | ± 0.025 |
| M | ± 0.05-0.15 | ± 0.08-0.20 | ± 0.130 |
| N | ± 0.05-0.15 | ± 0.08-0.20 | ± 0.025 |
| U | ± 0.08-0.25 | ± 0.13-0.38 | ± 0.130 |

d : Daire Ölçüsü / Inscribed Circle
m : Şekle Göre / Refer to Figure
t : Kalınlık / Thickness

9 Uç Tipi / Type of Insert

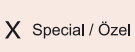
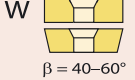
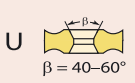
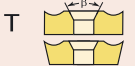
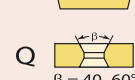
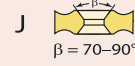
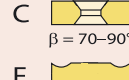
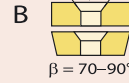

| | | |
|---|---|---|
| A | J | T |
| B | M | U |
| C | N | W |
| F | Q | X |
| G | R | |
| H | | |

β = 70-90°
β = 40-60°
β = 40-60°
β = 40-60°
β = 40-60°
β = 70-90°
β = 70-90°

10 Kesme Kenar Uzunluğu / Cutting Edge Length

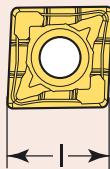

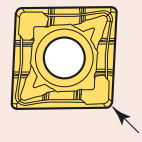

12 Köşe Konfigürasyonu / Corner Radius

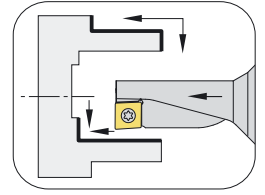
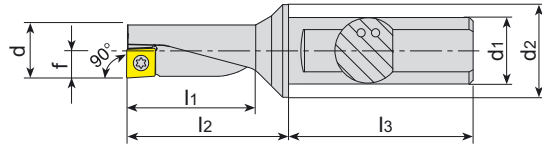

| | | | |
|----|---------|----|---------|
| 01 | r = 0.1 | 12 | r = 1.2 |
| 02 | r = 0.2 | 16 | r = 1.6 |
| 04 | r = 0.4 | 24 | r = 2.4 |
| 08 | r = 0.8 | | |



| Takım Kodu Ordering Code | Stok Stock | | Takım Ölçüleri (mm) Dimension (mm) | | | | | | | Kesici Uç Insert | Yedek Parçaları Spare Parts | |
|-----------------------------|---------------|---|---------------------------------------|----|----|------|------|----|------|--|---|---|
| | R | L | d | d1 | d2 | l1 | l2 | l3 | f | Sıkma Vidası Screw | Tork Anahtar Torx Key | |
| AEKL/R-D2.25X8 XC.. 040104 | ● | ● | 8 | 10 | 12 | 18 | 22 | 38 | 4 |  |  |  |
| AEKL/R-D2.25X10 XC.. 050204 | ● | ● | 10 | 12 | 16 | 22.5 | 27.5 | 42 | 5 | XC.. 050204 | 3006-M2x4 | 80-T06 |
| AEKL/R-D2.25X12 XC.. 060204 | ● | ● | 12 | 16 | 20 | 27 | 33 | 45 | 6 | XC.. 060204 | 3007-M2.2x5 | 80-T07 |
| AEKL/R-D2.25X14 XC.. 070304 | ● | ● | 14 | 16 | 20 | 31.5 | 38 | 45 | 7 | XC.. 070304 | 3008-M2.5x6 | 80-T08 |
| AEKL/R-D2.25X16 XC.. 080304 | ● | ● | 16 | 20 | 25 | 36 | 44 | 50 | 8 | XC.. 080304 | 1008-M3x6 | |
| AEKL/R-D2.25X18 XC.. 09T304 | ● | ● | 18 | 25 | 32 | 40.5 | 50 | 56 | 9 | XC.. 09T304 | 4015-M3.5x9 | 80-T15 |
| AEKL/R-D2.25X20 XC.. 10T304 | ● | ● | 20 | 25 | 32 | 45 | 55 | 56 | 10 | XC.. 10T304 | | |
| AEKL/R-D2.25X25 XC.. 130404 | ● | ● | 25 | 32 | 40 | 56.5 | 69 | 60 | 12.5 | XC.. 130404 | 4020-M4.5x10 | 80-T20 |
| AEKL/R-D2.25X32 XC.. 170504 | ● | ● | 32 | 40 | 50 | 72 | 88 | 70 | 16 | XC.. 170504 | 4020-M4.5x12 | |

R: Sağ/Right L: Sol/Left ● Stokta/In Stock ○ Stokta Yok/Non Stock Item
CRTZT-ISCR-TGTC-KRLY Ucuna Uygundur. / Compatible with CRTZT-ISCR-TGTC-KRLY Insert.

Sipariş Örneği/Ordering Example : 1 ad./pcs. AEKL-D2.25X8 XC.. 040104

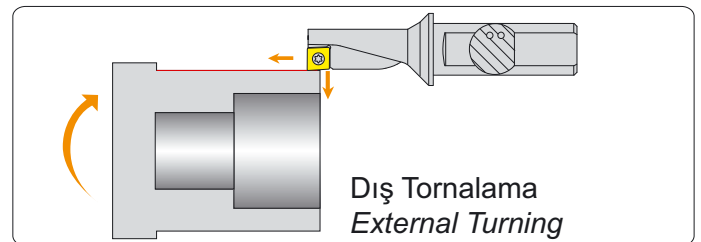
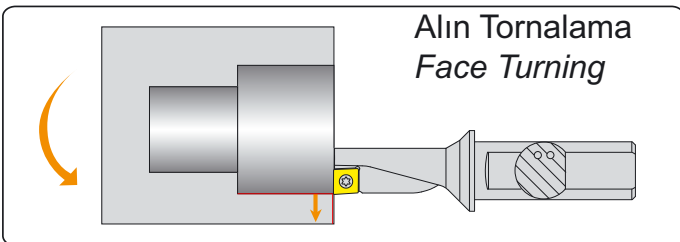
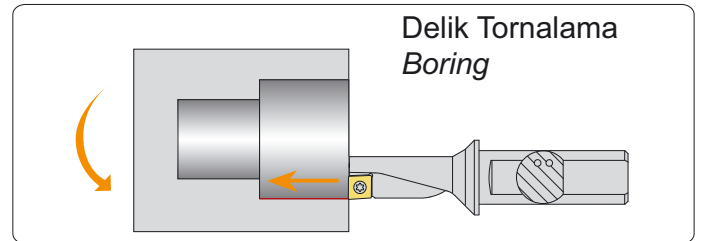
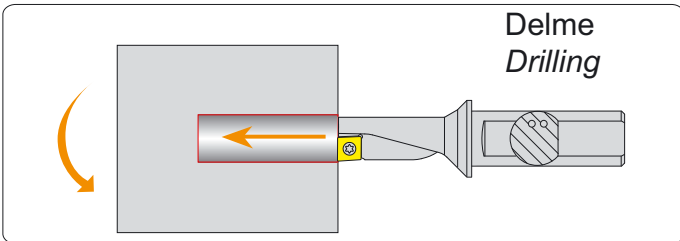
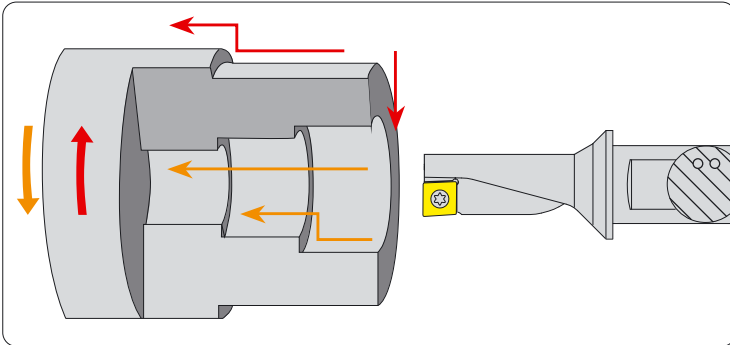

BARALAR

AYARLI DELİK İŞLEME BARALARI
ADJUSTABLE BORING HEADS

*konusulan
the spoken kalite...
quality...*



AKKO **A** **BH** **R** - **D16x42**

1 2 3 4

W16 - **L90**

5 6

2 Kesiş Stili / Cutter Style

BH : Delik İşleme / Boring Head

3 İşlem Tipi / Cutter Type

R : Kaba Baralama / Rough Boring
F : Hassas Baralama / Fine Boring

5 Montaj Formu / Assembly Form

W : Weldon

4 Takım Çapı / Tool Diameter

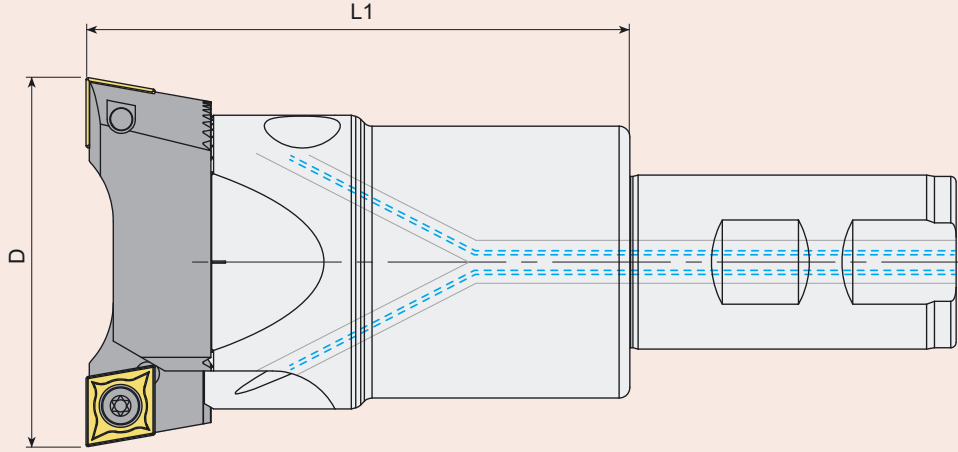

6 Takım Boyu / Tool Length

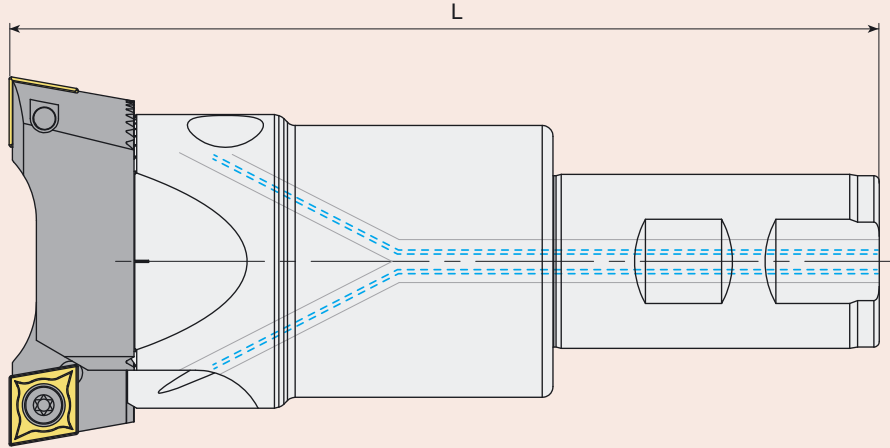

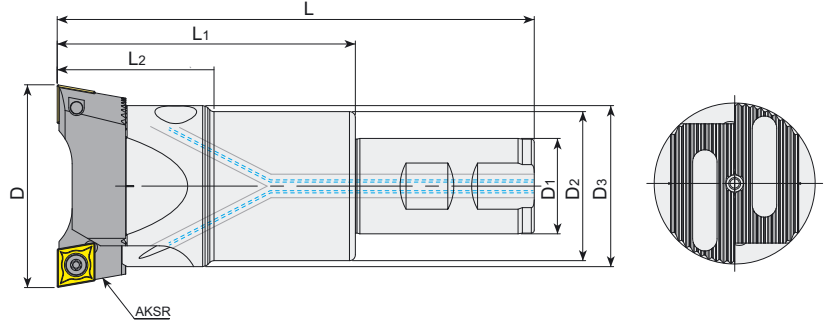





| Takım Kodu Ordering Code | Stok Stock | Ölçü Aralığı Boring Range | Takım Ölçüleri (mm) Dimension (mm) | | | | | Kartuş Cartridge | Yedek Parçaları Spare Parts | | | |
|-----------------------------|---------------|------------------------------|---------------------------------------|----|----|-----|-----|---------------------|--------------------------------|----------------|----------------------------------|--------------------------------|
| | | | D1 | D2 | D3 | L | L1 | | L2 | Pabuç Clamp | Kartuş Vidası Cartridge Screw | Ayar Vidası Adjusting Screw |
| ABHR-D16x42-W16-L90 | ● | 18-22 | 16 | - | - | 90 | 42 | - | AK.. 18-22 | ABKS-D16 | 2525-M3X14 | 2715-M3X4 |
| ABHR-D20x50-W20-L100 | ● | 22-28 | 20 | - | - | 100 | 50 | - | AK.. 22-28 | ABKS-D20 | 2503-M4X15 | 2715-M3X5 |
| ABHR-D25x60-W20-L110 | ● | 28-38 | 20 | 25 | - | 110 | 60 | - | AK.. 28-38 | ABKS-D25 | 2503-M4X20 | 2715-M3X8 |
| ABHR-D32x64-W25-L120 | ● | 36-50 | 25 | 32 | - | 120 | 64 | - | AK.. 36-50 | ABKS-D32 | 2504-M5X25 | 2702-M4X12 |
| ABHR-D40x80-W32-L140 | ● | 50-68 | 32 | 40 | - | 140 | 80 | - | AK.. 50-68 | ABKS-D40 | 2505-M6X30 | 2725-M5X14 |
| ABHR-D50x100-W32-L160 | ● | 68-90 | 32 | 50 | 54 | 160 | 100 | 50 | AK.. 68-90 | ABKS-D50 | 2506-M8X35 | 2725-M5X12 |
| ABHR-D63x80-W32-L140 | ● | 90-120 | 32 | 63 | 72 | 140 | 80 | 63 | AK.. 90-120 | ABKS-D63 | 2508-M10X40 | 2703-M6X16 |
| ABHR-D63x130-W40-L200 | ● | 90-120 | 40 | 63 | 72 | 200 | 130 | 63 | AK.. 90-120 | ABKS-D63 | 2508-M10X40 | 2703-M6X16 |
| ABHR-D80x140-W40-L210 | ● | 120-160 | 40 | 80 | 95 | 210 | 140 | 75 | AK.. 120-160 | ABKS-D80 | 2508-M10X40 | 2704-M8X25 |
| ABHR-D80x140-W40-L210-B | ● | 160-200 | 40 | 80 | 95 | 210 | 140 | 75 | AK.. 160-800 | ABKS-D80 | 2508-M10X40 | 2704-M8X25 |

R: Sağ/Right L: Sol/Left ● Stokta/In Stock ○ Stokta Yok/Non Stock Item

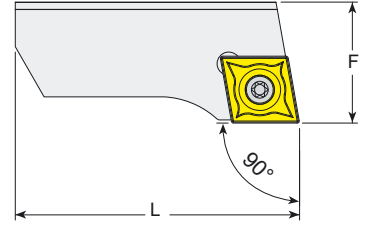
Siparişte, gövde ve kartuş set olarak verilecektir. / When ordered, body and cartridge will be sent as set.



Sipariş Örneği/Ordering Example : 1 ad./pcs. ABHR-D16x42-W16-L90

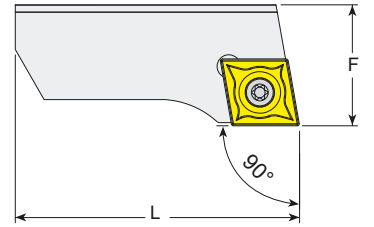

| Takım Kodu Ordering Code | Stok Stock | Takım Ölçüleri (mm) Dimension (mm) | | | Yedek Parçaları Spare Parts | | |
|-----------------------------|---------------|---------------------------------------|----|-----|---|---|---|
| | | Ölçü Aralığı Boring Range | F | L | Kesici Uç Insert | Sıkma Vidası Screw | Tork Anahtar Torx Key |
| | | | | |  |  |  |
| AKSR 18-22 | ● | 18-22 | 9 | 15 | CC.. 0602.. | 4008-M2.5x6 | 80-T08 |
| AKSR 22-28 | ● | 22-28 | 10 | 19 | | | |
| AKSR 28-38 | ● | 28-38 | 13 | 23 | | | |
| AKSR 36-50 | ● | 36-50 | 16 | 32 | CC.. 09T3.. | 4015-M3.5x8 | 80-T15 |
| AKSR 36-50-09 | ● | 36-50 | 16 | 32 | | | |
| AKSR 50-68 | ● | 50-68 | 20 | 40 | | | |
| AKSR 50-68-12 | ● | 50-68 | 20 | 40 | CC.. 1204.. | 1020-M5x11 | 80-T20 |
| AKSR 68-90 | ● | 68-90 | 23 | 54 | | | |
| AKSR 90-120 | ● | 90-120 | 28 | 70 | | | |
| AKSR 120-160 | ● | 120-160 | 33 | 95 | | | |
| AKSR 160-800 | ● | 160-800 | 33 | 130 | | | |

ISO Ucuna Uygunudur. / Compatible with ISO Insert.

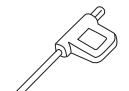

| Takım Kodu Ordering Code | Stok Stock | Takım Ölçüleri (mm) Dimension (mm) | | | Yedek Parçaları Spare Parts | | |
|-----------------------------|---------------|---------------------------------------|------|-----|---|---|---|
| | | Ölçü Aralığı Boring Range | F | L | Kesici Uç Insert | Sıkma Vidası Screw | Tork Anahtar Torx Key |
| | | | | |  |  |  |
| AKCR 28-38 | ● | 28-38 | 12.8 | 23 | CC.. 0602.. | 4008-M2.5x6 | 80-T08 |
| AKCR 36-50 | ● | 36-50 | 15.8 | 32 | | | |
| AKCR 36-50-09 | ● | 36-50 | 15.8 | 32 | | | |
| AKCR 50-68 | ● | 50-68 | 19.7 | 40 | CC.. 09T3.. | 4015-M3.5x8 | 80-T15 |
| AKCR 50-68-12 | ● | 50-68 | 19.7 | 40 | | | |
| AKCR 68-90 | ● | 68-90 | 22.7 | 54 | | | |
| AKCR 90-120 | ● | 90-120 | 27.7 | 70 | CC.. 1204.. | 1020-M5x11 | 80-T20 |
| AKCR 120-160 | ● | 120-160 | 32.7 | 95 | | | |
| AKCR 160-800 | ● | 160-800 | 32.7 | 130 | | | |

R: Sağ/Right L: Sol/Left ● Stokta/In Stock ○ Stokta Yok/Non Stock Item
ISO Ucuna Uygunudur. / Compatible with ISO Insert.

Sipariş Örneği/Ordering Example : 1 ad./pcs. AKSR 18-22

konusulan
the spoken kalite...
quality...

FREZELEME TAKIMLARI

MILLING TOOLS



AKKO
A

1

EM

2

90

3

A

4

P

5

10

6

D12

7

W16

8

L100

9

Z01

10

H

11

2 Kesiş Stili / Cutter Style

FM: Yüze Frezeleme Takımları - Face Milling Tools
EM: Alın ve Yüze Parmak Frezeleri - End Face Milling Tools
CM: Pah Kırma Parmak Frezeleri - Chamfering End Milling Tools
HM: Helis Parmak Frezeleri - Helix End Milling Tools
TSM: T Kanal Frezeleri - T Slot Milling Tools
HFM: Yüksek İlerleme Frezeleme Takımları - High Feed Milling Tools
PMR: Küresel Uçlu Parmak Frezeleri - Ball Nose End Milling Tools
SDM: Disk Frezeler / Slot Disc Milling
CBM: Silindirik Alyan Başlı Vida Havşalarını Açma Frezeleri
Countersink Milling Tool for Cylindrical Allen Head Screws

3 Freze Yanaşma Açısı / Lead Angle

90° - 75° - 60° - 45°
20° - 15° - 11° - 5° - 0°

6 Kesme Kenar Uzunluğu / Cutting Edge Length

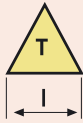
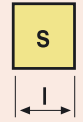
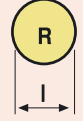
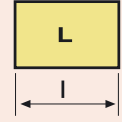
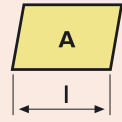

4 Uç Tipi / Insert Shape

| | | | |
|---|---|---|---|
| | | | |
| C | D | E | K |
| | | | |
| L | R | S | T |
| | | | |
| V | W | A | B |
| | | | |
| H | M | O | P |

5 Serbest Uç Açısı / Clearance angle of Insert

| | | |
|---|---|---|
| | | |
| A | B | C |
| | | |
| D | E | F |
| | | |
| G | N | P |

7 Takım Çapı / Tool Diameter

8 Montaj Formu ve Çapı / Assembly Form and Diameter

A, B, C, D,: ISO'ya göre montaj formu / Assembly form according to ISO
C: Silindirik Şaft / Cylindrical Shank
W: Weldon

9 Takım Boyu / Tool Length

10 Etkili Diş Adedi / Number of Effective Tooth

11 İçten Soğutmalı / With Coolant Hole



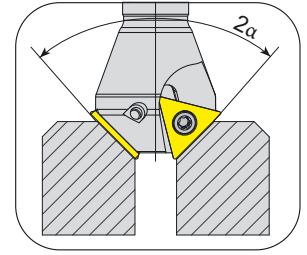
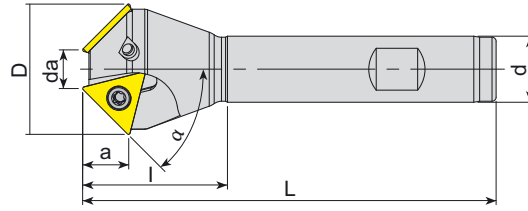

| Takım Kodu Ordering Code | Stok Stock | Takım Ölçüleri (mm) Dimension (mm) | | | | | | | Kesici Uç Insert | Yedek Parçaları Spare Parts | | |
|------------------------------------|---------------|---------------------------------------|------|----|----|-----|----|---|---------------------|--------------------------------|-----------------------|--------------------------|
| | | α | da | D | d | L | l | Z | | a | Sıkma Vidası Screw | Tork Anahtar Torx Key |
| ACM10-TC16-D17X20-W16-L90-Z01 | ● | 10° | 17 | 20 | 16 | 90 | 30 | 1 | 15.2 | TC.T 16T304 | 4015-M3.5x9 | 80-T15 |
| ACM15-TC16-D17X22-W16-L90-Z01 | ● | 15° | 17 | 22 | 16 | 90 | 30 | 1 | 14.9 | | | |
| ACM17.5-TC16-D17X24-W16-L90-Z01 | ● | 17.5° | 17 | 24 | 16 | 90 | 30 | 1 | 14.7 | | | |
| ACM18.5-TC16-D21.3X30-W20-L100-Z02 | ● | 18.5° | 21.3 | 30 | 20 | 100 | 30 | 2 | 13.5 | | | |
| ACM20-TC16-D12X20-W16-L100-Z01 | ● | 20° | 12 | 20 | 16 | 100 | 30 | 1 | 14.4 | | | |
| ACM20-TC16-D17X26-W16-L100-Z01 | ● | 20° | 17 | 26 | 16 | 100 | 30 | 1 | 14.4 | | | |
| ACM22.5-TC16-D17X28-W16-L100-Z01 | ● | 22.5° | 17 | 28 | 16 | 100 | 30 | 1 | 14.2 | | | |
| ACM25-TC16-D17X30-W16-L100-Z01 | ● | 25° | 17 | 30 | 16 | 100 | 30 | 1 | 13.9 | | | |
| ACM30-TC16-D6X20-W16-L100-Z01 | ● | 30° | 6 | 20 | 16 | 100 | 30 | 1 | 13.3 | | | |
| ACM30-TC16-D20X35-W16-L100-Z02 | ● | 30° | 20 | 35 | 16 | 100 | 35 | 2 | 13.3 | | | |
| ACM30-TC16-D30X45-W20-L100-Z02 | ● | 30° | 30 | 45 | 20 | 100 | 40 | 2 | 13.3 | | | |
| ACM45-TC09-D7X19-W16-L100-Z02 | ● | 45° | 7 | 19 | 16 | 100 | 25 | 2 | 5.9 | TC.T 090204 | 3007-M2.2x5 | 80-T07 |
| ACM45-TC11-D11X24-W16-L100-Z02 | ● | 45° | 11 | 24 | 16 | 100 | 25 | 2 | 6.9 | TC.T 110204 | 3008-M2.5x6 | 80-T08 |
| ACM45-TC16-D5X23-W16-L100-Z01 | ● | 45° | 5 | 23 | 16 | 100 | 30 | 1 | 10.8 | TC.T 16T304 | 4015-M3.5x9 | 80-T15 |
| ACM45-TC16-D10X30-W16-L100-Z02 | ● | 45° | 10 | 30 | 16 | 100 | 35 | 2 | 10.8 | | | |
| ACM45-TC16-D10X30-W20-L100-Z02 | ● | 45° | 10 | 30 | 20 | 100 | 35 | 2 | 10.8 | | | |
| ACM45-TC16-D18X37-W20-L100-Z02 | ● | 45° | 18 | 37 | 20 | 100 | 40 | 2 | 10.8 | | | |
| ACM45-TC16-D20X40-W20-L100-Z02 | ● | 45° | 20 | 40 | 20 | 100 | 40 | 2 | 10.8 | | | |
| ACM45-TC16-D30X50-W20-L100-Z02 | ● | 45° | 30 | 50 | 20 | 100 | 40 | 2 | 10.8 | | | |
| ACM55-TC16-D16X40-W20-L100-Z03 | ● | 55° | 16 | 40 | 20 | 100 | 40 | 3 | 8.7 | | | |
| ACM62-TC16-D14X40-W20-L100-Z03 | ● | 62° | 14 | 40 | 20 | 100 | 40 | 3 | 7.1 | | | |

R: Sağ/Right L: Sol/Left ● Stokta/In Stock ○ Stokta Yok/Non Stock Item
ISO Ucuna Uygunudur. / Compatible with ISO Insert.

Sipariş Örneği/Ordering Example : 1 ad./pcs. ACM10-TC16-D17X20-W16-L90-Z01
Kesme Hesabı : S 211 / Cutting Calculation : P 211



➤ S-SİSTEM PAH FREZELER
S-SYSTEM CHAMFERING END MILLS

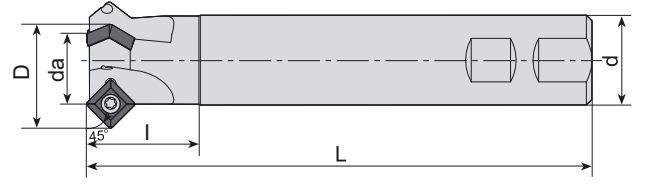
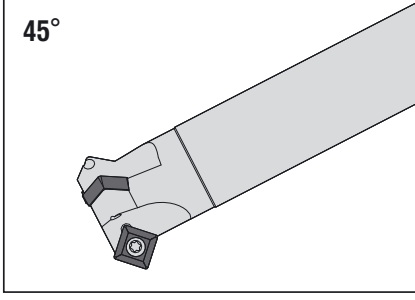

| Takım Kodu Ordering Code | Stok Stock | Takım Ölçüleri (mm) Dimension (mm) | | | | | | | | Kesici Uç Insert | Yedek Parçaları Spare Parts | |
|----------------------------------|---------------|---------------------------------------|----|----|----|-----|----|---|---|---------------------|--------------------------------|--------------------------|
| | | α | da | D | d | L | l | Z | a | | Sıkma Vidası Screw | Tork Anahtar Torx Key |
| ACM45-SP1104-D12x26-W20-L150-Z01 | ● | 45° | 12 | 26 | 20 | 150 | 30 | 1 | - | SPGT 110408 | 1515-M4x11 | 80-T15 |
| ACM45-SP1104-D25x39-W25-L150-Z02 | ● | 45° | 25 | 39 | 25 | 150 | 35 | 2 | - | | | |
| ACM45-SP1104-D32x46-W32-L150-Z03 | ● | 45° | 32 | 46 | 32 | 150 | 40 | 3 | - | | | |

ZCC Ucuna Uygundur. / Compatible with ZCC Insert.

➤ SİLİNDİRİK ALYAN BAŞLI VİDA (DIN 974-1) HAVŞALARINI AÇMA FREZELERİ
COUNTERSINK MILLING TOOL FOR CYLINDRICAL ALLEN HEAD SCREWS (DIN 974-1)

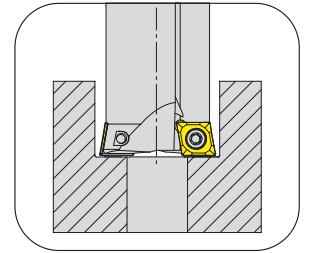
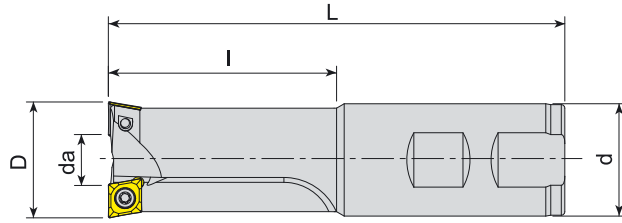

| Takım Kodu Ordering Code | Stok Stock | Takım Ölçüleri (mm) Dimension (mm) | | | | | | | Kesici Uç Insert | Yedek Parçaları Spare Parts | |
|-----------------------------------|---------------|---------------------------------------|----|----|----|-----|----------------------------------|-----------------------|---------------------|--------------------------------|--|
| | | da | D | d | l | L | Kullanılan Vidalar For Screws | Sıkma Vidası Screw | | Tork Anahtar Torx Key | |
| ACBM-CC06-D18X7-W16-L100-Z02-H | ● | 7 | 18 | 16 | 32 | 100 | M10 | CC.. 0602.. | 3008-M2.5x6 | 80-T08 | |
| ACBM-CC06-D20X9-W20-L100-Z02-H | ● | 9 | 20 | 20 | 40 | 100 | M12 | | | | |
| ACBM-CC09-D26X8.5-W25-L130-Z02-H | ● | 8.5 | 26 | 25 | 50 | 130 | M16 | CC.. 09T3.. | 4015-M3.5x9 | 80-T15 | |
| ACBM-CC09-D33X15.5-W32-L130-Z02-H | ● | 15.5 | 33 | 32 | 65 | 130 | M20 | | | | |

R: Sağ/Right L: Sol/Left ● Stokta/In Stock ○ Stokta Yok/Non Stock Item
ISO Ucuna Uygundur. / Compatible with ISO Insert.

Sipariş Örneği/Ordering Example : 1 ad./pcs. ACM45-SP1104-D12x26-W20-L150-Z01
Kesme Hesabı : S 211 / Cutting Calculation : P 211

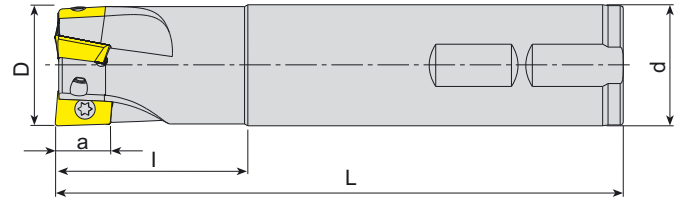

| Takım Kodu Ordering Code | Stok Stock | Takım Ölçüleri (mm) Dimension (mm) | | | | | | Kesici Uç Insert | Yedek Parçaları Spare Parts | |
|-------------------------------|---------------|---------------------------------------|---|----|-----|----|----|---------------------|--------------------------------|--------------------------|
| | | D | Z | d | L | l | a | | Sıkma Vidası Screw | Tork Anahtar Torx Key |
| AEM90-AD1505-D25-W25-L150-Z02 | ● | 25 | 2 | 25 | 150 | 50 | 15 | AD.. 1505.. | | |
| AEM90-AD1505-D30-W25-L150-Z03 | ● | 30 | 3 | 25 | 150 | 50 | 15 | | | |
| AEM90-AD1505-D32-W32-L150-Z03 | ● | 32 | 3 | 32 | 150 | 50 | 15 | | | |

ISCR Ucuna Uygun. / Compatiple with ISCR Insert.

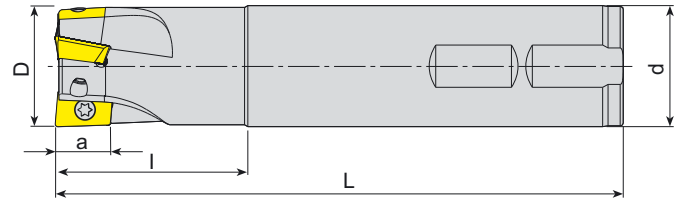

| Takım Kodu Ordering Code | Stok Stock | Takım Ölçüleri (mm) Dimension (mm) | | | | | | Kesici Uç Insert | Yedek Parçaları Spare Parts | |
|--------------------------------|---------------|---------------------------------------|---|----|-----|----|------|---------------------|--------------------------------|--------------------------|
| | | D | Z | d | L | l | a | | Sıkma Vidası Screw | Tork Anahtar Torx Key |
| AEM90-AD1505D-D25-W25-L150-Z02 | ● | 25 | 2 | 25 | 150 | 50 | 14.3 | ADKT 150508 | | |
| AEM90-AD1505D-D32-W32-L150-Z03 | ● | 32 | 3 | 32 | 150 | 50 | 14.3 | | | |

R: Sağ/Right L: Sol/Left ● Stokta/In Stock ○ Stokta Yok/Non Stock Item
DJT Ucuna Uygun. / Compatiple with DJT Insert.

Sipariş Örneği/Ordering Example : 1 ad./pcs. AEM90-AD1505-D25-W25-L150-Z02
Kesme Hesabı : S 211 / Cutting Calculation : P 211

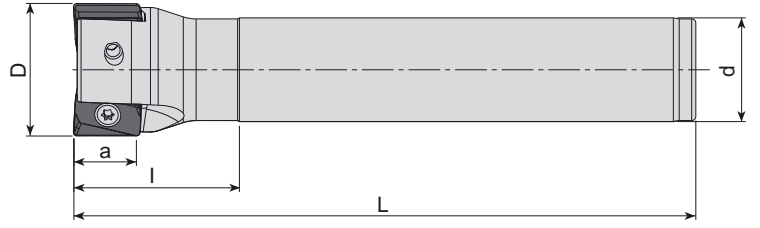
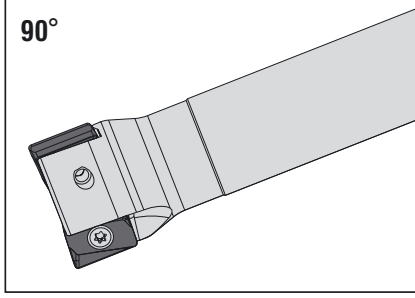

| Takım Kodu Ordering Code | Stok Stock | Takım Ölçüleri (mm) Dimension (mm) | | | | | | Kesici Uç Insert | Yedek Parçaları Spare Parts | |
|-----------------------------|---------------|---------------------------------------|---|----|-----|----|------|---------------------|--------------------------------|--------------------------|
| | | D | Z | d | L | l | a | | Sıkma Vidası Screw | Tork Anahtar Torx Key |
| AEM90-AN11-D25-W25-L150-Z02 | ● | 25 | 2 | 25 | 150 | 50 | 11.2 | ANGX 110504 | 4008-M3x8 | 80-T08 |
| AEM90-AN11-D32-W32-L150-Z03 | ● | 32 | 3 | 32 | 150 | 50 | 11.2 | | | |
| AEM90-AN11-D40-W32-L150-Z04 | ● | 40 | 4 | 32 | 150 | 50 | 11.2 | | | |

ZCC Ucuna Uygun. / Compatiple with ZCC Insert.

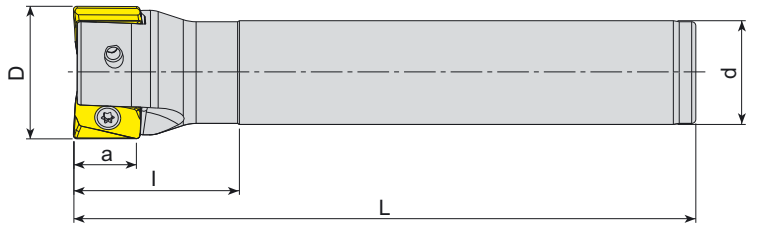





| Takım Kodu Ordering Code | Stok Stock | Takım Ölçüleri (mm) Dimension (mm) | | | | | | Kesici Uç Insert | Yedek Parçaları Spare Parts | |
|-------------------------------|---------------|---------------------------------------|---|----|-----|----|----|---------------------|--------------------------------|--------------------------|
| | | D | Z | d | L | l | a | | Sıkma Vidası Screw | Tork Anahtar Torx Key |
| AEM90-AN1607-D32-C25-L150-Z02 | ● | 32 | 2 | 25 | 150 | 50 | 15 | AN.X 1607 | 1515-M4x11 | 80-T15 |
| AEM90-AN1607-D40-C32-L150-Z03 | ● | 40 | 3 | 32 | 150 | 50 | 15 | | | |

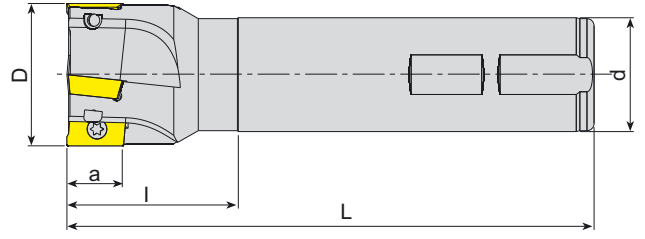

R: Sağ/Right L: Sol/Left ● Stokta/In Stock ○ Stokta Yok/Non Stock Item
TGTC Ucuna Uygun. / Compatiple with TGTC Insert.

Sipariş Örneği/Ordering Example : 1 ad./pcs. AEM90-AN11-D25-W25-L150-Z02
Kesme Hesabı : S 211 / Cutting Calculation : P 211

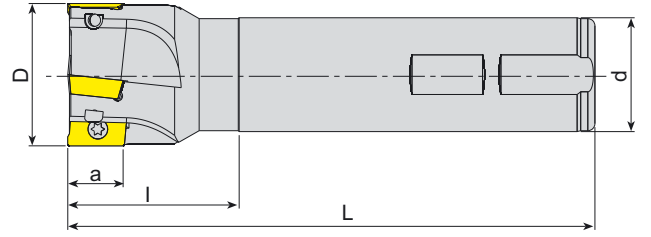

| Takım Kodu Ordering Code | Stok Stock | Takım Ölçüleri (mm) Dimension (mm) | | | | | | Kesici Uç Insert | Yedek Parçaları Spare Parts | |
|-------------------------------|---------------|---------------------------------------|---|----|-----|-----|----|--|--|---|
| | | D | Z | d | L | l | a | | Sıkma Vidası Screw | Tork Anahtar Torx Key |
| AEM90-AP10-D12-W16-L100-Z01-H | ● | 12 | 1 | 16 | 100 | 30 | 10 |  AP. 1003.. ISO UCUNA UYGUNDUR. FOR ISO INSERT. |  3008-M2.5x5 | |
| AEM90-AP10-D12-W16-L150-Z01 | ● | 12 | 1 | 16 | 150 | 38 | 10 | | | |
| AEM90-AP10-D14-W16-L100-Z01-H | ● | 14 | 1 | 16 | 100 | 30 | 10 | | | |
| AEM90-AP10-D14-W16-L150-Z01 | ● | 14 | 1 | 16 | 150 | 38 | 10 | | | |
| AEM90-AP10-D16-W16-L100-Z02-H | ● | 16 | 2 | 16 | 100 | 30 | 10 | | | |
| AEM90-AP10-D16-W16-L150-Z02 | ● | 16 | 2 | 16 | 150 | 50 | 10 | | | |
| AEM90-AP10-D16-C16-L150-Z02-H | ● | 16 | 2 | 16 | 150 | 50 | 10 | | | |
| AEM90-AP10-D16-C16-L200-Z02 | ● | 16 | 2 | 16 | 200 | 100 | 10 | | | |
| AEM90-AP10-D16-C16-L200-Z02-H | ● | 16 | 2 | 16 | 200 | 100 | 10 | | | |
| AEM90-AP10-D18-W16-L100-Z02-H | ● | 18 | 2 | 16 | 100 | 40 | 10 | | | |
| AEM90-AP10-D18-W16-L150-Z02 | ● | 18 | 2 | 16 | 150 | 40 | 10 | | | |
| AEM90-AP10-D20-W20-L100-Z03-H | ● | 20 | 3 | 20 | 100 | 30 | 10 | | | |
| AEM90-AP10-D20-W20-L150-Z03 | ● | 20 | 3 | 20 | 150 | 50 | 10 | | | |
| AEM90-AP10-D20-C20-L150-Z03-H | ● | 20 | 3 | 20 | 150 | 50 | 10 | | | |
| AEM90-AP10-D20-C20-L200-Z02 | ● | 20 | 2 | 20 | 200 | 100 | 10 | | | |
| AEM90-AP10-D20-C20-L200-Z03-H | ● | 20 | 3 | 20 | 200 | 100 | 10 | | | |
| AEM90-AP10-D21-W20-L150-Z03 | ● | 21 | 3 | 20 | 150 | 50 | 10 | | | |
| AEM90-AP10-D22-W20-L100-Z03-H | ● | 22 | 3 | 20 | 100 | 30 | 10 | | | |
| AEM90-AP10-D22-W20-L150-Z03 | ● | 22 | 3 | 20 | 150 | 50 | 10 | | | |
| AEM90-AP10-D24-W20-L150-Z03 | ● | 24 | 3 | 20 | 150 | 50 | 10 | | | |
| AEM90-AP10-D25-W25-L100-Z03-H | ● | 25 | 3 | 25 | 100 | 30 | 10 | | | |
| AEM90-AP10-D25-W25-L150-Z03 | ● | 25 | 3 | 25 | 150 | 50 | 10 | | | |
| AEM90-AP10-D25-C25-L200-Z02 | ● | 25 | 2 | 25 | 200 | 100 | 10 | | | |
| AEM90-AP10-D25-C25-L200-Z03 | ● | 25 | 3 | 25 | 200 | 100 | 10 | | | |
| AEM90-AP10-D25-C25-L250-Z02 | ● | 25 | 2 | 25 | 250 | 100 | 10 | | | |
| AEM90-AP10-D32-W25-L150-Z04 | ● | 32 | 4 | 25 | 150 | 50 | 10 | | | |
| AEM90-AP10-D32-W32-L150-Z04 | ● | 32 | 4 | 32 | 150 | 50 | 10 | | | |
| AEM90-AP10-D40-W32-L150-Z05 | ● | 40 | 5 | 32 | 150 | 50 | 10 | | | |
| AEM90-AP11-D16-W16-L150-Z02 | ● | 16 | 2 | 16 | 150 | 50 | 11 |  AP. 11T3.. ISO UCUNA UYGUNDUR. FOR ISO INSERT. |  3008-M2.5x6 |  80-T08 |
| AEM90-AP11-D16-C16-L150-Z02 | ● | 16 | 2 | 16 | 150 | 50 | 11 | | | |
| AEM90-AP11-D16-C16-L150-Z02-H | ● | 16 | 2 | 16 | 150 | 50 | 11 | | | |
| AEM90-AP11-D16-C16-L200-Z02 | ● | 16 | 2 | 16 | 200 | 100 | 11 | | | |
| AEM90-AP11-D17-C16-L150-Z02 | ● | 17 | 2 | 16 | 150 | 50 | 11 | | | |
| AEM90-AP11-D17-C16-L200-Z02 | ● | 17 | 2 | 16 | 200 | 100 | 11 | | | |
| AEM90-AP11-D20-W20-L150-Z03 | ● | 20 | 3 | 20 | 150 | 50 | 11 | | | |
| AEM90-AP11-D20-W20-L150-Z03-H | ● | 20 | 3 | 20 | 150 | 50 | 11 | | | |
| AEM90-AP11-D20-C20-L150-Z03 | ● | 20 | 3 | 20 | 150 | 50 | 11 | | | |
| AEM90-AP11-D20-C20-L200-Z03 | ● | 20 | 3 | 20 | 200 | 100 | 11 | | | |
| AEM90-AP11-D21-W20-L150-Z03 | ● | 21 | 3 | 20 | 150 | 50 | 11 | | | |
| AEM90-AP11-D21-W20-L150-Z03-H | ● | 21 | 3 | 20 | 150 | 50 | 11 | | | |
| AEM90-AP11-D21-C20-L150-Z03 | ● | 21 | 3 | 20 | 150 | 50 | 11 | | | |
| AEM90-AP11-D21-C20-L200-Z03 | ● | 21 | 3 | 20 | 200 | 100 | 11 | | | |
| AEM90-AP11-D25-W25-L150-Z03 | ● | 25 | 3 | 25 | 150 | 50 | 11 | | | |
| AEM90-AP11-D25-W25-L150-Z03-H | ● | 25 | 3 | 25 | 150 | 50 | 11 | | | |
| AEM90-AP11-D25-C25-L150-Z03 | ● | 25 | 3 | 25 | 150 | 50 | 11 | | | |
| AEM90-AP11-D26-C25-L150-Z03 | ● | 26 | 3 | 25 | 150 | 50 | 11 | | | |
| AEM90-AP11-D32-W25-L150-Z04 | ● | 32 | 4 | 25 | 150 | 50 | 11 | | | |
| AEM90-AP11-D32-W32-L150-Z03-H | ● | 32 | 3 | 32 | 150 | 50 | 11 | | | |
| AEM90-AP11-D32-W32-L150-Z04 | ● | 32 | 4 | 32 | 150 | 50 | 11 | | | |



| Takım Kodu Ordering Code | Stok Stock | Takım Ölçüleri (mm) Dimension (mm) | | | | | | Kesici Uç Insert | Yedek Parçaları Spare Parts | |
|-------------------------------|---------------|---------------------------------------|---|----|-----|-----|----|--|--------------------------------|--------------------------|
| | | D | Z | d | L | l | a | | Sıkma Vidası Screw | Tork Anahtar Torx Key |
| AEM90-AP1204-D20-C20-L150-Z02 | ● | 20 | 2 | 20 | 150 | 30 | 12 |  AP. 1204.. TGTC UCUNA UYGUNDUR. FOR TGTC INSERT. | 1510-M3.5x7 | 80-T10 |
| AEM90-AP1204-D21-C20-L150-Z02 | ● | 21 | 2 | 20 | 150 | 30 | 12 | | | |
| AEM90-AP1204-D21-C20-L200-Z02 | ● | 21 | 2 | 20 | 200 | 30 | 12 | | | |
| AEM90-AP1204-D25-C25-L150-Z03 | ● | 25 | 3 | 25 | 150 | 40 | 12 | | | |
| AEM90-AP1204-D26-C25-L250-Z02 | ● | 26 | 2 | 25 | 250 | 35 | 12 | | | |
| AEM90-AP1204-D32-C25-L150-Z03 | ● | 32 | 3 | 25 | 150 | 35 | 12 | | 1510-M3.5x9 | |
| AEM90-AP16-D25-W25-L100-Z02-H | ● | 25 | 2 | 25 | 100 | 35 | 16 |  AP. 1604.. ISO UCUNA UYGUNDUR. FOR ISO INSERT. | 1515-M4x9 | 80-T15 |
| AEM90-AP16-D25-W25-L150-Z02 | ● | 25 | 2 | 25 | 150 | 50 | 16 | | | |
| AEM90-AP16-D25-C25-L250-Z02 | ● | 25 | 2 | 25 | 250 | 100 | 16 | | | |
| AEM90-AP16-D28-W25-L100-Z03-H | ● | 28 | 3 | 25 | 100 | 40 | 16 | | | |
| AEM90-AP16-D28-W25-L150-Z03 | ● | 28 | 3 | 25 | 150 | 50 | 16 | | | |
| AEM90-AP16-D30-W25-L110-Z03-H | ● | 30 | 3 | 25 | 110 | 40 | 16 | | | |
| AEM90-AP16-D30-W25-L150-Z03 | ● | 30 | 3 | 25 | 150 | 50 | 16 | | | |
| AEM90-AP16-D32-W32-L110-Z03-H | ● | 32 | 3 | 32 | 110 | 40 | 16 | | | |
| AEM90-AP16-D32-W25-L150-Z03 | ● | 32 | 3 | 25 | 150 | 50 | 16 | | | |
| AEM90-AP16-D32-W32-L150-Z03 | ● | 32 | 3 | 32 | 150 | 50 | 16 | | | |
| AEM90-AP16-D32-C32-L150-Z03 | ● | 32 | 3 | 32 | 150 | 50 | 16 | | | |
| AEM90-AP16-D32-C32-L250-Z02 | ● | 32 | 2 | 32 | 250 | 100 | 16 | | | |
| AEM90-AP16-D32-C32-L250-Z03 | ● | 32 | 3 | 32 | 250 | 100 | 16 | | | |
| AEM90-AP16-D35-W32-L150-Z03 | ● | 35 | 3 | 32 | 150 | 50 | 16 | | | |
| AEM90-AP16-D36-W32-L110-Z03-H | ● | 36 | 3 | 32 | 110 | 40 | 16 | | | |
| AEM90-AP16-D36-W32-L150-Z03 | ● | 36 | 3 | 32 | 150 | 50 | 16 | | | |
| AEM90-AP16-D40-W32-L110-Z04-H | ● | 40 | 4 | 32 | 110 | 40 | 16 | | | |
| AEM90-AP16-D40-W32-L150-Z04 | ● | 40 | 4 | 32 | 150 | 50 | 16 | | | |
| AEM90-AP16-D40-C32-L150-Z04 | ● | 40 | 4 | 32 | 150 | 50 | 16 | | | |
| AEM90-AP16-D40-C32-L250-Z02 | ● | 40 | 2 | 32 | 250 | 50 | 16 | | | |
| AEM90-AP16-D40-C32-L250-Z04 | ● | 40 | 4 | 32 | 250 | 50 | 16 | | | |
| AEM90-AP1705-D25-C25-L120-Z02 | ● | 25 | 2 | 25 | 120 | 40 | 16 | AP. 1705.. TGTC-LMN UCUNA UYGUNDUR. FOR TGTC-LMN INSERT. | | |
| AEM90-AP1705-D26-C25-L200-Z02 | ● | 26 | 2 | 25 | 200 | 40 | 16 | | | |
| AEM90-AP1705-D26-C25-L250-Z02 | ● | 26 | 2 | 25 | 250 | 40 | 16 | | | |
| AEM90-AP1705-D32-C25-L150-Z03 | ● | 32 | 3 | 25 | 150 | 45 | 16 | | | |
| AEM90-AP1705-D33-C32-L300-Z02 | ● | 33 | 2 | 32 | 300 | 40 | 16 | | | |

R: Sağ/Right L: Sol/Left ● Stokta/In Stock ○ Stokta Yok/Non Stock Item

Sipariş Örneği/Ordering Example : 1 ad./pcs. AEM90-AP1204-D20-C20-L150-Z02

Kesme Hesabı : S 211 / Cutting Calculation : P 211

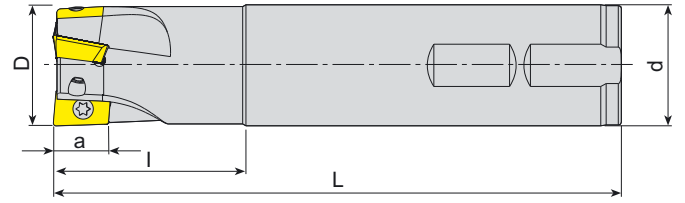

| Takım Kodu Ordering Code | Stok Stock | Takım Ölçüleri (mm) Dimension (mm) | | | | | | Kesici Uç Insert | Yedek Parçaları Spare Parts | |
|---------------------------------|---------------|---------------------------------------|---|----|-----|----|-----|---------------------|--------------------------------|--------------------------|
| | | D | Z | d | L | l | a | | Sıkma Vidası Screw | Tork Anahtar Torx Key |
| AEM90-AX0602-D10-C10-L120-Z02 | ● | 10 | 2 | 10 | 120 | 20 | 5.7 | AX.. 0602 | 3006-M1.8x4 | 80-T06 |
| AEM90-AX0602-D12-C11-L120-Z02 | ● | 12 | 2 | 11 | 120 | 20 | 5.7 | | | |
| AEM90-AX0602-D12-C12-L120-Z02 | ● | 12 | 2 | 12 | 120 | 20 | 5.7 | | | |
| AEM90-AX0602-D14-C12-L120-Z03 | ● | 14 | 3 | 12 | 120 | 20 | 5.7 | | | |
| AEM90-AX0602-D16-W16-L120-Z04-H | ● | 16 | 4 | 16 | 120 | 20 | 5.7 | | | |
| AEM90-AX0602-D16-W16-L150-Z04-H | ● | 16 | 4 | 16 | 150 | 20 | 5.7 | | | |
| AEM90-AX0602-D20-W20-L120-Z05-H | ● | 20 | 5 | 20 | 120 | 25 | 5.7 | | | |
| AEM90-AX0602-D20-W20-L150-Z05-H | ● | 20 | 5 | 20 | 150 | 25 | 5.7 | | | |
| AEM90-AX0903-D16-C16-L120-Z02 | ● | 16 | 2 | 16 | 120 | 30 | 8.8 | AX.. 0903 | 3008-M2.5x5 | 80-T08 |
| AEM90-AX0903-D16-C16-L180-Z02 | ● | 16 | 2 | 16 | 180 | 30 | 8.8 | | | |
| AEM90-AX0903-D17-C16-L120-Z02 | ● | 17 | 2 | 16 | 120 | 25 | 8.8 | | | |
| AEM90-AX0903-D17-C16-L180-Z02 | ● | 17 | 2 | 16 | 180 | 25 | 8.8 | | | |
| AEM90-AX0903-D20-C20-L120-Z03 | ● | 20 | 3 | 20 | 120 | 30 | 8.8 | | | |
| AEM90-AX0903-D20-C20-L200-Z02 | ● | 20 | 2 | 20 | 200 | 30 | 8.8 | | | |
| AEM90-AX0903-D21-C20-L120-Z03 | ● | 21 | 3 | 20 | 120 | 25 | 8.8 | | | |
| AEM90-AX0903-D21-C20-L200-Z02 | ● | 21 | 2 | 20 | 200 | 25 | 8.8 | | | |
| AEM90-AX0903-D25-C25-L150-Z03 | ● | 25 | 3 | 25 | 150 | 30 | 8.8 | | | |
| AEM90-AX0903-D25-C25-L250-Z02 | ● | 25 | 2 | 25 | 250 | 40 | 8.8 | | | |
| AEM90-AX0903-D26-C25-L150-Z03 | ● | 26 | 3 | 25 | 150 | 30 | 8.8 | | | |

R: Sağ/Right L: Sol/Left ● Stokta/In Stock ○ Stokta Yok/Non Stock Item
TGTC Ucuna Uygundur. / Compatible with TGTC Insert.

Sipariş Örneği/Ordering Example : 1 ad./pcs. AEM90-AX0602-D10-C10-L120-Z02
Kesme Hesabı : S 211 / Cutting Calculation : P 211



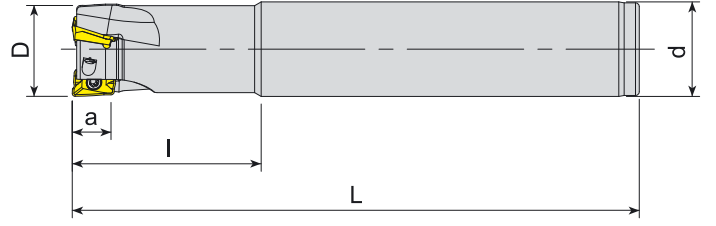

| Takım Kodu Ordering Code | Stok Stock | Takım Ölçüleri (mm) Dimension (mm) | | | | | | Kesici Uç Insert | Yedek Parçaları Spare Parts | |
|---------------------------------|---------------|---------------------------------------|---|----|-----|----|----|---------------------|--------------------------------|--------------------------|
| | | D | Z | d | L | l | a | | Sıkma Vidası Screw | Tork Anahtar Torx Key |
| AEM90-AX1235-D16-C14-L120-Z02-H | ● | 16 | 2 | 14 | 120 | 25 | 10 | | | |
| AEM90-AX1235-D16-C16-L150-Z02 | ● | 16 | 2 | 16 | 150 | 30 | 10 | | | |
| AEM90-AX1235-D20-C20-L150-Z02 | ● | 20 | 2 | 20 | 150 | 40 | 10 | | | |
| AEM90-AX1235-D20-C20-L150-Z03 | ● | 20 | 3 | 20 | 150 | 40 | 10 | | | |
| AEM90-AX1235-D25-C20-L120-Z04-H | ● | 25 | 4 | 20 | 120 | 30 | 10 | | | |
| AEM90-AX1235-D25-C25-L150-Z03 | ● | 25 | 3 | 25 | 150 | 50 | 10 | | | |
| AEM90-AX1705-D25-C25-L150-Z02 | ● | 25 | 2 | 25 | 150 | 50 | 14 | | | |
| AEM90-AX1705-D32-C32-L150-Z03 | ● | 32 | 3 | 32 | 150 | 50 | 14 | | | |

SMTM Ucuna Uygunur. / Compatiple with SMTM Insert.

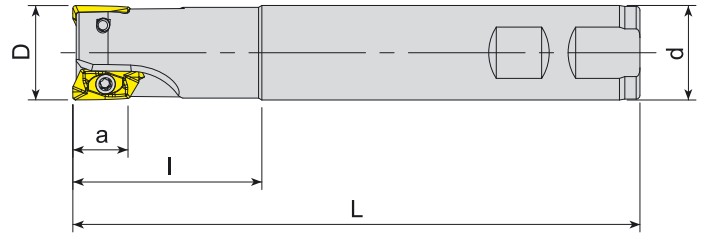

| Takım Kodu Ordering Code | Stok Stock | Takım Ölçüleri (mm) Dimension (mm) | | | | | | Kesici Uç Insert | Yedek Parçaları Spare Parts | |
|-------------------------------|---------------|---------------------------------------|---|----|-----|----|------|---------------------|--------------------------------|--------------------------|
| | | D | Z | d | L | l | a | | Sıkma Vidası Screw | Tork Anahtar Torx Key |
| AEM90-ED1404-D20-W20-L150-Z02 | ● | 20 | 2 | 20 | 150 | 50 | 14.5 | | | |
| AEM90-ED1404-D25-W25-L150-Z02 | ● | 25 | 2 | 25 | 150 | 50 | 14.5 | | | |

R: Sağ/Right L: Sol/Left ● Stokta/In Stock ○ Stokta Yok/Non Stock Item
KNMTL Ucuna Uygunur. / Compatiple with KNMTL Insert.

Sipariş Örneği/Ordering Example : 1 ad./pcs. AEM90-AX1235-D16-C14-L120-Z02-H
Kesme Hesabı : S 211 / Cutting Calculation : P 211

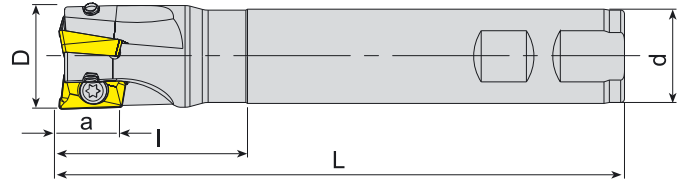

| Takım Kodu Ordering Code | Stok Stock | Takım Ölçüleri (mm) Dimension (mm) | | | | | | Kesici Uç Insert | Yedek Parçaları Spare Parts | |
|----------------------------------|---------------|---------------------------------------|---|----|-----|----|------|---------------------|--------------------------------|--------------------------|
| | | D | Z | d | L | l | a | | Sıkma Vidası Screw | Tork Anahtar Torx Key |
| AEM90-R390.11-D16-W16-L100-Z02-H | ● | 16 | 2 | 16 | 100 | 30 | 10 | R390-11T3.. | 3008-M2.5x6 | 80-T08 |
| AEM90-R390.11-D16-W16-L150-Z02 | ● | 16 | 2 | 16 | 150 | 50 | 10 | | | |
| AEM90-R390.11-D16-W16-L150-Z02-H | ● | 16 | 2 | 16 | 150 | 50 | 10 | | | |
| AEM90-R390.11-D20-W20-L090-Z02-H | ● | 20 | 2 | 20 | 90 | 30 | 10 | | | |
| AEM90-R390.11-D20-W20-L100-Z03-H | ● | 20 | 3 | 20 | 100 | 30 | 10 | | | |
| AEM90-R390.11-D20-W20-L150-Z03 | ● | 20 | 3 | 20 | 150 | 50 | 10 | | | |
| AEM90-R390.11-D20-W20-L150-Z03-H | ● | 20 | 3 | 20 | 150 | 50 | 10 | | | |
| AEM90-R390.11-D22-W20-L090-Z02-H | ● | 22 | 2 | 20 | 90 | 30 | 10 | | | |
| AEM90-R390.11-D25-W25-L100-Z03-H | ● | 25 | 3 | 25 | 100 | 35 | 10 | | | |
| AEM90-R390.11-D25-W25-L150-Z03 | ● | 25 | 3 | 25 | 150 | 50 | 10 | | | |
| AEM90-R390.11-D25-W25-L150-Z03-H | ● | 25 | 3 | 25 | 150 | 50 | 10 | | | |
| AEM90-R390.11-D30-W25-L150-Z04-H | ● | 30 | 4 | 25 | 150 | 40 | 10 | | | |
| AEM90-R390.11-D32-W32-L150-Z05-H | ● | 32 | 5 | 32 | 150 | 50 | 10 | | | |
| AEM90-R390.17-D25-W25-L150-Z02 | ● | 25 | 2 | 25 | 150 | 50 | 15.4 | | | |
| AEM90-R390.17-D25-W25-L150-Z02-H | ● | 25 | 2 | 25 | 150 | 50 | 15.4 | 4015-M3.5x9 | | |
| AEM90-R390.17-D30-W25-L150-Z03 | ● | 30 | 3 | 25 | 150 | 50 | 15.4 | | | |
| AEM90-R390.17-D30-W25-L150-Z03-H | ● | 30 | 3 | 25 | 150 | 50 | 15.4 | | | |

R: Sağ/Right L: Sol/Left ● Stokta/In Stock ○ Stokta Yok/Non Stock Item
SNDVK Ucuna Uygundur. / Compatible with SNDVK Insert.

Sipariş Örneği/Ordering Example : 1 ad./pcs. AEM90-R390.11-D16-W16-L100-Z02-H
Kesme Hesabı : S 211 / Cutting Calculation : P 211



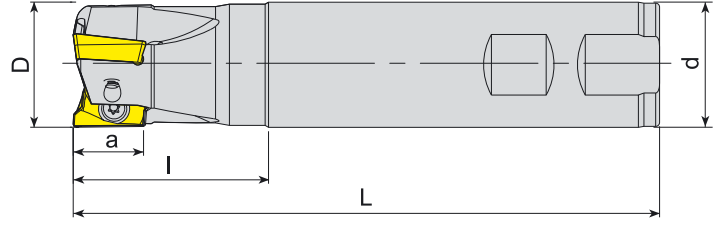

| Takım Kodu Ordering Code | Stok Stock | Takım Ölçüleri (mm) Dimension (mm) | | | | | | Kesici Uç Insert | Yedek Parçaları Spare Parts | |
|-------------------------------|---------------|---------------------------------------|---|----|-----|-----|----|---------------------|--------------------------------|--------------------------|
| | | D | Z | d | L | l | a | | Sıkma Vidası Screw | Tork Anahtar Torx Key |
| AEM90-RT07-D10-W10-L120-Z02 | ● | 10 | 2 | 10 | 120 | 30 | 7 | RT 0702 | 3006-M2x4 | 80-T06 |
| AEM90-RT07-D12-C12-L120-Z02 | ● | 12 | 2 | 12 | 120 | 30 | 7 | | | |
| AEM90-RT07-D12-W12-L120-Z02 | ● | 12 | 2 | 12 | 120 | 30 | 7 | | | |
| AEM90-RT07-D14-W12-L120-Z02 | ● | 14 | 2 | 12 | 120 | 30 | 7 | | | |
| AEM90-RT10-D16-W16-L120-Z02-H | ● | 16 | 2 | 16 | 120 | 30 | 10 | RT 1003 | 3008-M2.5x6 | 80-T08 |
| AEM90-RT10-D16-W16-L150-Z02 | ● | 16 | 2 | 16 | 150 | 50 | 10 | | | |
| AEM90-RT10-D16-C15-L160-Z02 | ● | 16 | 2 | 15 | 160 | 30 | 10 | | | |
| AEM90-RT10-D17-W16-L160-Z02 | ● | 17 | 2 | 16 | 160 | 30 | 10 | | | |
| AEM90-RT10-D18-W16-L120-Z02-H | ● | 18 | 2 | 16 | 120 | 30 | 10 | | | |
| AEM90-RT10-D20-W20-L120-Z03-H | ● | 20 | 3 | 20 | 120 | 30 | 10 | | | |
| AEM90-RT10-D20-W20-L150-Z03 | ● | 20 | 3 | 20 | 150 | 50 | 10 | | | |
| AEM90-RT10-D20-C19-L200-Z03 | ● | 20 | 3 | 19 | 200 | 100 | 10 | | | |
| AEM90-RT10-D20-C20-L200-Z03 | ● | 20 | 3 | 20 | 200 | 100 | 10 | | | |
| AEM90-RT10-D21-W20-L200-Z03 | ● | 21 | 3 | 20 | 200 | 30 | 10 | | | |
| AEM90-RT10-D22-W20-L120-Z03-H | ● | 22 | 3 | 20 | 120 | 30 | 10 | | | |
| AEM90-RT10-D22-C20-L150-Z03 | ● | 22 | 3 | 20 | 150 | 50 | 10 | | | |
| AEM90-RT10-D22-C20-L200-Z03 | ● | 22 | 3 | 20 | 200 | 30 | 10 | | | |
| AEM90-RT10-D25-W25-L120-Z04-H | ● | 25 | 4 | 25 | 120 | 40 | 10 | | | |
| AEM90-RT10-D25-W25-L150-Z04 | ● | 25 | 4 | 25 | 150 | 50 | 10 | | | |
| AEM90-RT10-D25-C25-L200-Z04 | ● | 25 | 4 | 25 | 200 | 100 | 10 | | | |
| AEM90-RT10-D32-W32-L120-Z05-H | ● | 32 | 5 | 32 | 120 | 50 | 10 | | | |
| AEM90-RT10-D32-W32-L150-Z05 | ● | 32 | 5 | 32 | 150 | 50 | 10 | | | |
| AEM90-RT10-D32-C32-L200-Z05 | ● | 32 | 5 | 32 | 200 | 100 | 10 | | | |
| AEM90-RT13-D32-C32-L250-Z04 | ● | 32 | 4 | 32 | 250 | 50 | 13 | RT 1304 | 1008-M3x8 | |
| AEM90-RT16-D25-W25-L120-Z02-H | ● | 25 | 2 | 25 | 120 | 40 | 16 | RT 1606 | 1515-M4x9 | 80-T15 |
| AEM90-RT16-D25-W25-L150-Z02 | ● | 25 | 2 | 25 | 150 | 50 | 16 | | | |
| AEM90-RT16-D25-C25-L200-Z02 | ● | 25 | 2 | 25 | 200 | 100 | 16 | | | |
| AEM90-RT16-D32-W32-L120-Z03-H | ● | 32 | 3 | 32 | 120 | 50 | 16 | | | |
| AEM90-RT16-D32-W32-L150-Z03 | ● | 32 | 3 | 32 | 150 | 50 | 16 | | | |
| AEM90-RT16-D32-C32-L200-Z03 | ● | 32 | 3 | 32 | 200 | 100 | 16 | | | |
| AEM90-RT16-D32-C32-L250-Z03 | ● | 32 | 3 | 32 | 250 | 100 | 16 | | | |
| AEM90-RT16-D32-C32-L270-Z03 | ● | 32 | 3 | 32 | 270 | 100 | 16 | | | |
| AEM90-RT16-D40-W32-L120-Z04-H | ● | 40 | 4 | 32 | 120 | 50 | 16 | | | |
| AEM90-RT16-D40-W32-L150-Z04 | ● | 40 | 4 | 32 | 150 | 50 | 16 | | | |
| AEM90-RT16-D40-C32-L200-Z04 | ● | 40 | 4 | 32 | 200 | 100 | 16 | | | |
| | | | | | | | | | | |

R: Sağ/Right L: Sol/Left ● Stokta/In Stock ○ Stokta Yok/Non Stock Item
SFTY Ucuna Uygundur. / Compatible with SFTY Insert.

Sipariş Örneği/Ordering Example : 1 ad./pcs. AEM90-RT07-D10-W10-L120-Z02
Kesme Hesabı : S 211 / Cutting Calculation : P 211

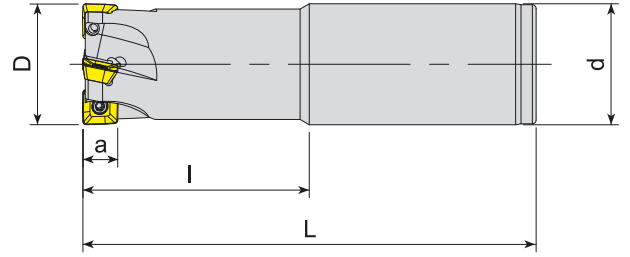

| Takım Kodu Ordering Code | Stok Stock | Takım Ölçüleri (mm) Dimension (mm) | | | | | | Kesici Uç Insert | Yedek Parçaları Spare Parts | |
|-------------------------------|---------------|---------------------------------------|---|----|-----|----|-----|---------------------|--------------------------------|--------------------------|
| | | D | Z | d | L | l | a | | Sıkma Vidası Screw | Tork Anahtar Torx Key |
| AEM90-SE09-D25-C25-L120-Z03-H | ● | 25 | 3 | 25 | 120 | 60 | 6.7 | SEET 09T3.. | 1008-M3x8 | 80-T08 |
| AEM90-SE09-D25-C25-L150-Z02 | ● | 25 | 2 | 25 | 150 | 50 | 6.7 | | | |
| AEM90-SE09-D32-C32-L120-Z04-H | ● | 32 | 4 | 32 | 120 | 60 | 6.7 | | | |
| AEM90-SE09-D32-C32-L150-Z03 | ● | 32 | 3 | 32 | 150 | 50 | 6.7 | | | |

ZCC Ucuna Uygunudur. / Compatible with ZCC Insert.

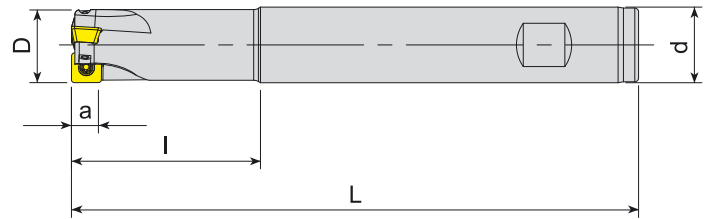



| Takım Kodu Ordering Code | Stok Stock | Takım Ölçüleri (mm) Dimension (mm) | | | | | | Kesici Uç Insert | Yedek Parçaları Spare Parts | |
|---------------------------------|---------------|---------------------------------------|---|----|-----|----|-----|---------------------|--------------------------------|--------------------------|
| | | D | Z | d | L | l | a | | Sıkma Vidası Screw | Tork Anahtar Torx Key |
| AEM90-SPGT0602-D16-W16-L150-Z02 | ● | 16 | 2 | 16 | 150 | 50 | 5.5 | SPGT 060204 | 3007-M2.2x5 | 80-T07 |
| AEM90-SPGT07T3-D20-W20-L150-Z03 | ● | 20 | 3 | 20 | 150 | 50 | 7 | SPGT 07T308 | 3008-M2.5x6 | 80-T08 |
| AEM90-SPGT07T3-D25-W25-L150-Z03 | ● | 25 | 3 | 25 | 150 | 50 | 7 | | | |

R: Sağ/Right L: Sol/Left ● Stokta/In Stock ○ Stokta Yok/Non Stock Item
ZCC Ucuna Uygunudur. / Compatible with ZCC Insert.

Sipariş Örneği/Ordering Example : 1 ad./pcs. AEM90-SPGT0602-D16-W16-L150-Z02
Kesme Hesabı : S 211 / Cutting Calculation : P 211

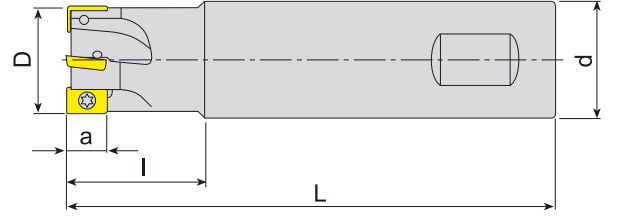
90°





| Takım Kodu Ordering Code | Stok Stock | Takım Ölçüleri (mm) Dimension (mm) | | | | | | Kesici Uç Insert | Yedek Parçaları Spare Parts | |
|-----------------------------|---------------|---------------------------------------|---|----|-----|----|----|---|---|---|
| | | D | Z | d | L | l | a | | Sıkma Vidası Screw | Tork Anahtar Torx Key |
| AEM90-XC13-D20-W20-L150-Z02 | ● | 20 | 2 | 20 | 150 | 60 | 13 |  |  |  |
| AEM90-XC13-D25-W25-L150-Z03 | ● | 25 | 3 | 25 | 150 | 60 | 13 | | 1008-M3x6 | |
| AEM90-XC13-D32-W32-L150-Z04 | ● | 32 | 4 | 32 | 150 | 60 | 13 | | 1008-M3x8 | |

SC Ucuna Uygunur. / Compatible with SC Insert.

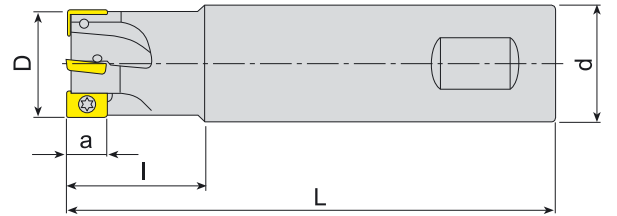
90°

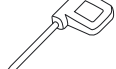

| Takım Kodu Ordering Code | Stok Stock | Takım Ölçüleri (mm) Dimension (mm) | | | | | | Kesici Uç Insert | Yedek Parçaları Spare Parts | |
|-------------------------------|---------------|---------------------------------------|---|----|-----|----|----|--|---|---|
| | | D | Z | d | L | l | a | | Sıkma Vidası Screw | Tork Anahtar Torx Key |
| AEM90-XD11T3-D16-W16-L150-Z02 | ● | 16 | 2 | 16 | 150 | 40 | 10 |  |  |  |
| AEM90-XD11T3-D17-C16-L150-Z02 | ● | 17 | 2 | 16 | 150 | 30 | 10 | | | |
| AEM90-XD11T3-D20-W20-L150-Z03 | ● | 20 | 3 | 20 | 150 | 50 | 10 | | | |
| AEM90-XD11T3-D25-W25-L150-Z04 | ● | 25 | 4 | 25 | 150 | 50 | 10 | | | |
| AEM90-XD11T3-D32-W32-L150-Z04 | ● | 32 | 4 | 32 | 150 | 50 | 10 | | | |

R: Sağ/Right L: Sol/Left ● Stokta/In Stock ○ Stokta Yok/Non Stock Item
CRTZT Ucuna Uygunur. / Compatible with CRTZT Insert.

Sipariş Örneği/Ordering Example : 1 ad./pcs. AEM90-XC13-D20-W20-L150-Z02
Kesme Hesabı : S 211 / Cutting Calculation : P 211

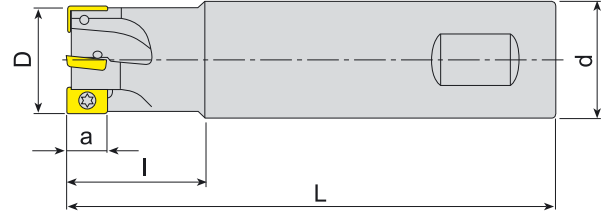

| Takım Kodu Ordering Code | Stok Stock | Takım Ölçüleri (mm) Dimension (mm) | | | | | | Kesici Uç Insert | Yedek Parçaları Spare Parts | |
|-----------------------------|---------------|---------------------------------------|---|----|-----|-----|----|---------------------|--------------------------------|--------------------------|
| | | D | Z | d | L | l | a | | Sıkma Vidası Screw | Tork Anahtar Torx Key |
| AEM90-XO06-D10-C12-L120-Z02 | ● | 10 | 2 | 12 | 120 | 50 | 5 | | | |
| AEM90-XO06-D12-C12-L120-Z02 | ● | 12 | 2 | 12 | 120 | 25 | 5 | | | |
| AEM90-XO09-D16-W16-L150-Z02 | ● | 16 | 2 | 16 | 150 | 50 | 8 | | | |
| AEM90-XO09-D20-W20-L150-Z03 | ● | 20 | 3 | 20 | 150 | 50 | 8 | | | |
| AEM90-XO12-D20-W20-L150-Z02 | ● | 20 | 2 | 20 | 150 | 50 | 11 | | | |
| AEM90-XO12-D20-C20-L200-Z02 | ● | 20 | 2 | 20 | 200 | 100 | 11 | | | |
| AEM90-XO12-D22-W20-L150-Z02 | ● | 22 | 2 | 20 | 150 | 20 | 11 | | | |
| AEM90-XO12-D25-W25-L150-Z03 | ● | 25 | 3 | 25 | 150 | 50 | 11 | | | |
| AEM90-XO12-D25-C25-L200-Z03 | ● | 25 | 3 | 25 | 200 | 100 | 11 | | | |
| AEM90-XO12-D32-C25-L150-Z04 | ● | 32 | 4 | 25 | 150 | 40 | 11 | | | |
| AEM90-XO12-D32-W32-L150-Z04 | ● | 32 | 4 | 32 | 150 | 50 | 11 | | | |
| AEM90-XO12-D32-C32-L250-Z04 | ● | 32 | 4 | 32 | 250 | 100 | 11 | | | |

SC Ucuna Uygundur. / Compatible with SC Insert.

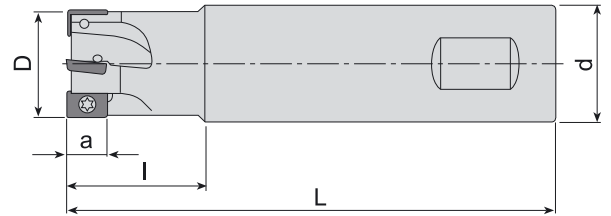





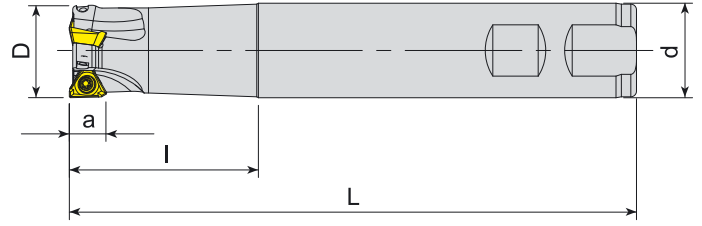

| Takım Kodu Ordering Code | Stok Stock | Takım Ölçüleri (mm) Dimension (mm) | | | | | | Kesici Uç Insert | Yedek Parçaları Spare Parts | |
|-------------------------------|---------------|---------------------------------------|---|----|-----|----|---|---------------------|--------------------------------|--------------------------|
| | | D | Z | d | L | l | a | | Sıkma Vidası Screw | Tork Anahtar Torx Key |
| AEM90-ZC1003-D16-C14-L150-Z02 | ● | 16 | 2 | 14 | 150 | 25 | 9 | | | |
| AEM90-ZC1003-D17-C16-L150-Z02 | ● | 17 | 2 | 16 | 150 | 25 | 9 | | | |
| AEM90-ZC1003-D20-C18-L150-Z03 | ● | 20 | 3 | 18 | 150 | 25 | 9 | | | |
| AEM90-ZC1003-D21-C20-L150-Z03 | ● | 21 | 3 | 20 | 150 | 30 | 9 | | | |
| AEM90-ZC1003-D25-C20-L150-Z03 | ● | 25 | 3 | 20 | 150 | 30 | 9 | | | |
| AEM90-ZC1003-D26-C25-L170-Z03 | ● | 26 | 3 | 25 | 170 | 25 | 9 | | | |
| AEM90-ZC1003-D32-C25-L180-Z04 | ● | 32 | 4 | 25 | 180 | 30 | 9 | | | |
| AEM90-ZC1003-D33-C32-L200-Z04 | ● | 33 | 4 | 32 | 200 | 25 | 9 | | | |

R: Sağ/Right L: Sol/Left ● Stokta/In Stock ○ Stokta Yok/Non Stock Item
DJT Ucuna Uygundur. / Compatible with DJT Insert.

Sipariş Örneği/Ordering Example : 1 ad./pcs. AEM90-XO06-D10-C12-L120-Z02
Kesme Hesabı : S 211 / Cutting Calculation : P 211

> S-SİSTEM YÜZEY PARMAK FREZELER
S-SYSTEM END MILLS



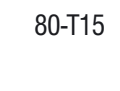





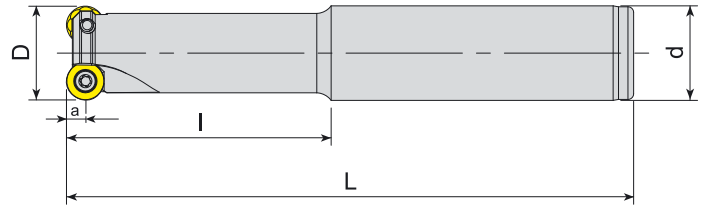

| Takım Kodu Ordering Code | Stok Stock | Takım Ölçüleri (mm) Dimension (mm) | | | | | | Kesici Uç Insert | Yedek Parçaları Spare Parts | |
|-------------------------------|---------------|---------------------------------------|---|----|-----|----|----|---|---|---|
| | | D | Z | d | L | l | a | | Sıkma Vidası Screw | Tork Anahtar Torx Key |
| AEM90-3P1004-D20-W20-L150-Z02 | ● | 20 | 2 | 20 | 150 | 40 | 7 |  |  |  |
| AEM90-3P1004-D25-W25-L150-Z03 | ● | 25 | 3 | 25 | 150 | 40 | 7 | | | |
| AEM90-3P1505-D32-W32-L150-Z03 | ● | 32 | 3 | 32 | 150 | 50 | 11 |  |  |  |
| AEM90-3P1505-D40-W32-L150-Z04 | ● | 40 | 4 | 32 | 150 | 35 | 11 | | | |

TGTC Ucuna Uygun. / Compatible with TGTC Insert.

> S-SİSTEM YÜZEY ve KOPYA PARMAK FREZELER
S-SYSTEM FACE and COPY END MILLS



| Takım Kodu Ordering Code | Stok Stock | Takım Ölçüleri (mm) Dimension (mm) | | | | | | Kesici Uç Insert | Yedek Parçaları Spare Parts | | | |
|--------------------------------|---------------|---------------------------------------|---|----|-----|----|---|---|--|---|---|---|
| | | D | Z | d | L | l | a | | Sıkma Vidası Screw | Baskı Parçası Wedge Clamp | Baskı Vidası Clamp Screw | Tork Anahtar Torx Key |
| AEMR-QP10T3-D20-C20-L150-Z01-H | ● | 20 | 1 | 20 | 150 | 70 | 5 |  |  |  |  |  |
| AEMR-QP10T3-D25-C25-L150-Z02-H | ● | 25 | 2 | 25 | 150 | 70 | 5 | | | | | |
| AEMR-QP10T3-D25-C25-L170-Z02 | ● | 25 | 2 | 25 | 170 | 90 | 5 | | | | | |
| AEMR-QP10T3-D32-C32-L150-Z03-H | ● | 32 | 3 | 32 | 150 | 70 | 5 | | | | | |
| AEMR-QP10T3-D32-C32-L170-Z03 | ● | 32 | 3 | 32 | 170 | 90 | 5 | | | | | |
| AEMR-QP1204-D25-C25-L150-Z02-H | ● | 25 | 2 | 25 | 150 | 70 | 6 |  |  |  |  | |

R: Sağ/Right L: Sol/Left ● Stokta/In Stock ○ Stokta Yok/Non Stock Item
SMTM Ucuna Uygun. / Compatible with SMTM Insert.

Sipariş Örneği/Ordering Example : 1 ad./pcs. AEM90-3P1004-D20-W20-L150-Z02
Kesme Hesabı : S 211 / Cutting Calculation : P 211

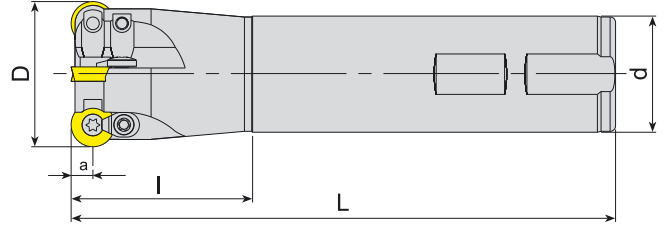



| Takım Kodu Ordering Code | Stok Stock | Takım Ölçüleri (mm) Dimension (mm) | | | | | Kesici Uç Insert | Yedek Parçaları Spare Parts | | | | | | | | | |
|--------------------------------|---------------|---------------------------------------|---|----|-----|-----|---------------------|--------------------------------|--------------------------|------------------------------|-----------------------------|--------------------------|-----------|-------------|--------|--------------|--------|
| | | D | Z | d | L | l | | a | Sıkma Vidası Screw | Baskı Parçası Wedge Clamp | Baskı Vidası Clamp Screw | Tork Anahtar Torx Key | | | | | |
| AEMR-RD0501-D08-W10-L100-Z01-H | ● | 8 | 1 | 10 | 100 | 20 | 2.5 | RD.. 0501 | 3006-M2x3.6 3006-M2x4 | | | 80-T06 | | | | | |
| AEMR-RD0501-D10-W12-L100-Z02-H | ● | 10 | 2 | 12 | 100 | 20 | 2.5 | | | | | | | | | | |
| AEMR-RD0501-D12-W12-L120-Z02-H | ● | 12 | 2 | 12 | 120 | 20 | 2.5 | RD.. 08T2 | 3008-M2.5x6 | - | - | 80-T08 | | | | | |
| AEMR-RD08T2-D16-W16-L150-Z02 | ● | 16 | 2 | 16 | 150 | 60 | 4 | | | | | | | | | | |
| AEMR-RD08T2-D20-W20-L150-Z02 | ● | 20 | 2 | 20 | 150 | 60 | 4 | RD.. 0803 | 1008-M3x6 | | | | | | | | |
| AEMR-RD0803-D16-W16-L150-Z02 | ● | 16 | 2 | 16 | 150 | 60 | 4 | | | | | | | | | | |
| AEMR-RD0803-D16-C20-L200-Z02 | ● | 16 | 2 | 20 | 200 | 60 | 4 | RD.. 1003 | | | | | | | | | |
| AEMRC-RD1003-D20-W20-L150-Z02 | ● | 20 | 2 | 20 | 150 | 60 | 5 | | | | | | | | | | |
| AEMRC-RD1003-D20-C20-L160-Z02 | ● | 20 | 2 | 20 | 160 | 70 | 5 | | | | | | | | | | |
| AEMRC-RD1003-D20-C20-L250-Z02 | ● | 20 | 2 | 20 | 250 | 150 | 5 | | | | | | | | | | |
| AEMRC-RD1003-D25-W25-L150-Z02 | ● | 25 | 2 | 25 | 150 | 60 | 5 | | | | | | | | | | |
| AEMRC-RD1003-D25-C25-L160-Z02 | ● | 25 | 2 | 25 | 160 | 70 | 5 | | | | | | | | | | |
| AEMRC-RD1003-D25-W25-L200-Z02 | ● | 25 | 2 | 25 | 200 | 100 | 5 | | | | | | | | | | |
| AEMRC-RD1003-D25-C25-L200-Z02 | ● | 25 | 2 | 25 | 200 | 100 | 5 | | | | | | | | | | |
| AEMRC-RD1003-D25-C25-L250-Z02 | ● | 25 | 2 | 25 | 250 | 150 | 5 | | | | | | | | | | |
| AEMRC-RD1003-D32-W32-L150-Z03 | ● | 32 | 3 | 32 | 150 | 60 | 5 | | | | | | | | | | |
| AEMRC-RD1003-D32-C32-L250-Z02 | ● | 32 | 2 | 32 | 250 | 150 | 5 | | | | | | | | | | |
| AEMRC-RD1003-D40-W32-L150-Z04 | ● | 40 | 4 | 32 | 150 | 50 | 5 | | | | | | | | | | |
| AEMRC-RD1003-D40-C32-L250-Z02 | ● | 40 | 2 | 32 | 250 | 50 | 5 | | | | | | | | | | |
| AEMRC-RD10T3-D20-W20-L150-Z02 | ● | 20 | 2 | 20 | 150 | 60 | 5 | | | | | | RD.. 10T3 | 4015-M3.5x9 | ACK-15 | 1015-M3.5x11 | 80-T15 |
| AEMRC-RD10T3-D25-W25-L150-Z02 | ● | 25 | 2 | 25 | 150 | 60 | 5 | | | | | | | | | | |
| AEMRC-RD10T3-D32-W32-L150-Z03 | ● | 32 | 3 | 32 | 150 | 60 | 5 | | | | | | | | | | |
| AEMRC-RD12T3-D25-W25-L150-Z02 | ● | 25 | 2 | 25 | 150 | 60 | 6 | RD.. 12T3 | | | | | | | | | |
| AEMRC-RD12T3-D25-W25-L200-Z02 | ● | 25 | 2 | 25 | 200 | 100 | 6 | | | | | | | | | | |
| AEMRC-RD12T3-D25-C25-L250-Z02 | ● | 25 | 2 | 25 | 250 | 150 | 6 | | | | | | | | | | |
| AEMRC-RD12T3-D32-W32-L150-Z03 | ● | 32 | 3 | 32 | 150 | 60 | 6 | | | | | | | | | | |
| AEMRC-RD12T3-D32-C32-L250-Z02 | ● | 32 | 2 | 32 | 250 | 150 | 6 | | | | | | | | | | |
| AEMRC-RD12T3-D40-W32-L150-Z04 | ● | 40 | 4 | 32 | 150 | 50 | 6 | | | | | | | | | | |
| AEMRC-RD12T3-D40-C32-L250-Z02 | ● | 40 | 2 | 32 | 250 | 50 | 6 | RD.. 1204 | | | | | | | | | |
| AEMRC-RD1204-D32-C32-L160-Z03 | ● | 32 | 3 | 32 | 160 | 70 | 6 | | | | | | | | | | |
| AEMRC-RD1204-D32-W32-L160-Z03 | ● | 32 | 3 | 32 | 160 | 70 | 6 | RD.. 1604 | 1515-M4.5x11 | ACK-05 | 1515-M4x11 | | | | | | |
| AEMRC-RD1604-D40-W32-L150-Z02 | ● | 40 | 2 | 32 | 150 | 50 | 8 | | | | | | | | | | |

R: Sağ/Right L: Sol/Left ● Stokta/In Stock ○ Stokta Yok/Non Stock Item
ISO Ucuna Uygundur. / Compatible with ISO Insert.

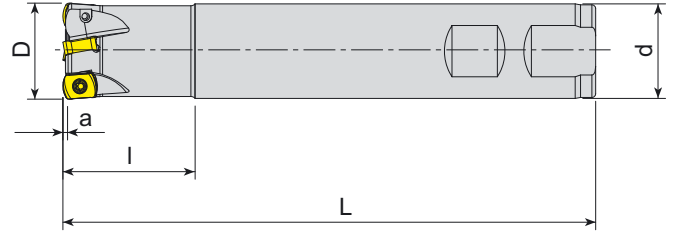

Sipariş Örneği/Ordering Example : 1 ad./pcs. AEMR-RD0501-D08-W10-L100-Z01-H
Kesme Hesabı : S 211 / Cutting Calculation : P 211

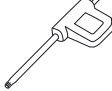

| Takım Kodu Ordering Code | Stok Stock | Takım Ölçüleri (mm) Dimension (mm) | | | | | | Kesici Uç Insert | Yedek Parçaları Spare Parts | |
|------------------------------|---------------|---------------------------------------|---|----|-----|----|---|---|---|---|
| | | D | Z | d | L | l | a | | Sıkma Vidası Screw | Tork Anahtar Torx Key |
| AHFM-BL0603-D17-W16-L170-Z02 | ● | 17 | 2 | 16 | 170 | 20 | 1 |  |  |  |
| AHFM-BL0603-D21-W20-L200-Z03 | ● | 21 | 3 | 20 | 200 | 25 | 1 | | | |
| AHFM-BL0603-D26-W25-L200-Z04 | ● | 26 | 4 | 25 | 200 | 35 | 1 | | | |

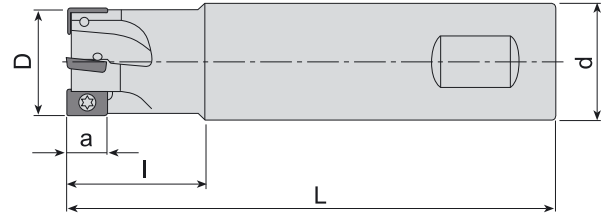
TGTC Ucuna Uygunudur. / Compatible with TGTC Insert.





| Takım Kodu Ordering Code | Stok Stock | Takım Ölçüleri (mm) Dimension (mm) | | | | | | Kesici Uç Insert | Yedek Parçaları Spare Parts | |
|------------------------------|---------------|---------------------------------------|---|----|-----|----|---|---|---|---|
| | | D | Z | d | L | l | a | | Sıkma Vidası Screw | Tork Anahtar Torx Key |
| AHFM-E00602-D10-C09-L120-Z02 | ● | 10 | 2 | 9 | 120 | 15 | - |  |  |  |
| AHFM-E00602-D10-C10-L080-Z02 | ● | 10 | 2 | 10 | 80 | 20 | - | | | |
| AHFM-E00602-D10-C10-L120-Z02 | ● | 10 | 2 | 10 | 120 | 60 | - | | | |
| AHFM-E00602-D12-C11-L120-Z03 | ● | 12 | 3 | 11 | 120 | 15 | - | | | |
| AHFM-E00602-D12-C12-L080-Z03 | ● | 12 | 3 | 12 | 80 | 20 | - | | | |
| AHFM-E00602-D12-C12-L120-Z03 | ● | 12 | 3 | 12 | 120 | 60 | - | | | |
| AHFM-E00602-D16-C16-L150-Z04 | ● | 16 | 4 | 16 | 150 | 60 | - | | | |

R: Sağ/Right L: Sol/Left ● Stokta/In Stock ○ Stokta Yok/Non Stock Item
DJT Ucuna Uygunudur. / Compatible with DJT Insert.

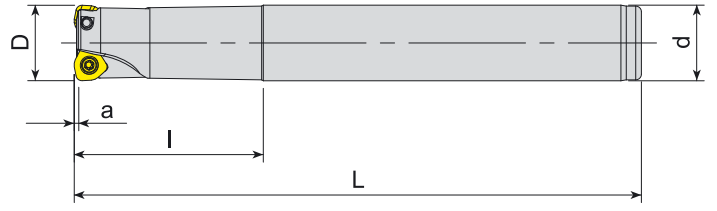



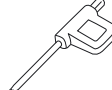



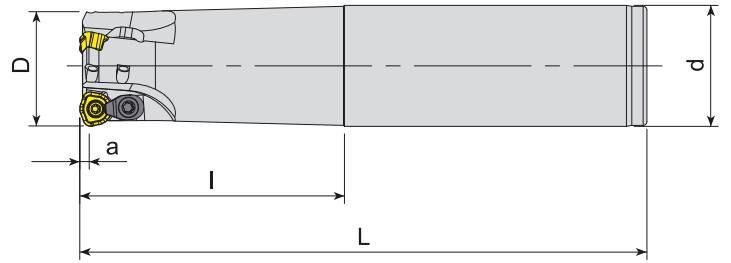







Sipariş Örneği/Ordering Example : 1 ad./pcs. AHFM-BL0603-D17-W16-L170-Z02
Kesme Hesabı : S 211 / Cutting Calculation : P 211

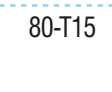

| Takım Kodu Ordering Code | Stok Stock | Takım Ölçüleri (mm) Dimension (mm) | | | | | | Kesici Uç Insert | Yedek Parçaları Spare Parts | | |
|-------------------------------|---------------|---------------------------------------|---|----|-----|----|-----|--|---|---|--------|
| | | D | Z | d | L | l | a | | Sıkma Vidası Screw | Tork Anahtar Torx Key | |
| AHFM-WD0503D-D20-C20-L150-Z02 | ● | 20 | 2 | 20 | 150 | 50 | 1.2 |  |  |  | 80-T10 |

DJT Ucuna Uygunur. / Compatiple with DJT Insert.

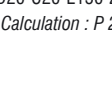

| Takım Kodu Ordering Code | Stok Stock | Takım Ölçüleri (mm) Dimension (mm) | | | | | | Kesici Uç Insert | Yedek Parçaları Spare Parts | | | | |
|-------------------------------|---------------|---------------------------------------|---|----|-----|----|-----|---|--|---|---|---|--------|
| | | D | Z | d | L | l | a | | Sıkma Vidası Screw | Baskı Parçası Wedge Clamp | Baskı Vidası Clamp Screw | Tork Anahtar Torx Key | |
| AHFM-WD0603-D20-C20-L150-Z03 | ● | 20 | 3 | 20 | 150 | 70 | 2 |  |  | - | - |  | 80-T08 |
| AHFMC-WD0804-D25-C25-L150-Z02 | ● | 25 | 2 | 25 | 150 | 70 | 2.5 |  |  |  |  |  | 80-T10 |
| AHFMC-WD0804-D32-C32-L150-Z03 | ● | 32 | 3 | 32 | 150 | 70 | 2.5 |  |  |  |  |  | 80-T15 |
| AHFMC-WD1205-D32-C32-L150-Z02 | ● | 32 | 2 | 32 | 150 | 70 | 3 |  |  |  |  |  | 80-T15 |

R: Sağ/Right L: Sol/Left ● Stokta/In Stock ○ Stokta Yok/Non Stock Item
SMTM Ucuna Uygunur. / Compatiple with SMTM Insert.

Sipariş Örneği/Ordering Example : 1 ad./pcs. AHFM-WD0503D-D20-C20-L150-Z02
Kesme Hesabı : S 211 / Cutting Calculation : P 211

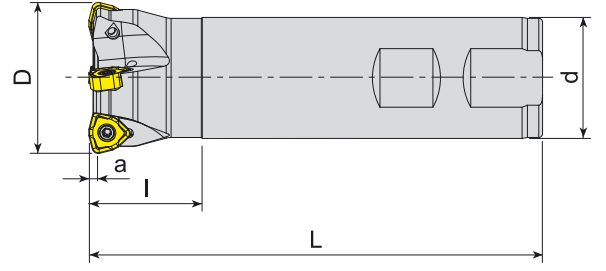

| Takım Kodu Ordering Code | Stok Stock | Takım Ölçüleri (mm) Dimension (mm) | | | | | | Kesici Uç Insert | Yedek Parçaları Spare Parts | |
|---------------------------------|---------------|---------------------------------------|---|----|-----|-----|-----|---|---|---|
| | | D | Z | d | L | l | a | | Sıkma Vidası Screw | Tork Anahtar Torx Key |
| AHFM-WN09T3-D25-W25-L120-Z02-H | ● | 25 | 2 | 25 | 120 | 40 | 1.5 |  |  |  |
| AHFML-WN09T3-D25-W25-L120-Z02-H | ● | 25 | 2 | 25 | 120 | 40 | 1.5 | | | |
| AHFM-WN09T3-D25-C25-L200-Z02 | ● | 25 | 2 | 25 | 200 | 120 | 1.5 | | | |
| AHFM-WN09T3-D30-W25-L120-Z03-H | ● | 30 | 3 | 25 | 120 | 30 | 1.5 | | | |
| AHFM-WN09T3-D40-W32-L120-Z04-H | ● | 40 | 4 | 32 | 120 | 30 | 1.5 | | | |
| AHFM-WN09T3-D40-C32-L200-Z04 | ● | 40 | 4 | 32 | 200 | 30 | 1.5 | | | |

R: Sağ/Right L: Sol/Left ● Stokta/In Stock ○ Stokta Yok/Non Stock Item
KRLY Ucuna Uygunudur. / Compatible with KRLY Insert.

Sipariş Örneği/Ordering Example : 1 ad./pcs. AHFM-WN09T3-D25-W25-L120-Z02-H
Kesme Hesabı : S 211 / Cutting Calculation : P 211



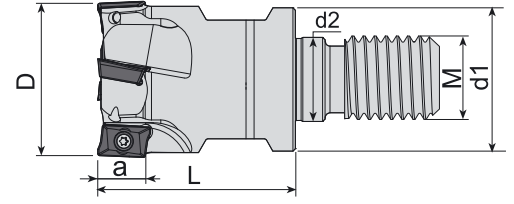

| Takım Kodu Ordering Code | Stok Stock | Takım Ölçüleri (mm) Dimension (mm) | | | | | | | Kesici Uç Insert | Yedek Parçaları Spare Parts | |
|---------------------------------|---------------|---------------------------------------|---|----|-----|----|------|------|---------------------|--------------------------------|--------------------------|
| | | D | Z | d1 | M | L | d2 | a | | Sıkma Vidası Screw | Tork Anahtar Torx Key |
| AEM90-AD1505D-D25-M12-L43-Z02-H | ● | 25 | 2 | 21 | M12 | 43 | 12.5 | 14.3 | ADKT 150508 | 1515-M4x9 | 80-T15 |
| AEM90-AD1505D-D32-M16-L43-Z03-H | ● | 32 | 3 | 29 | M16 | 43 | 17 | 14.3 | | 1515-M4x11 | |

DJT Ucuna Uygundur. / Compatible with DJT Insert.

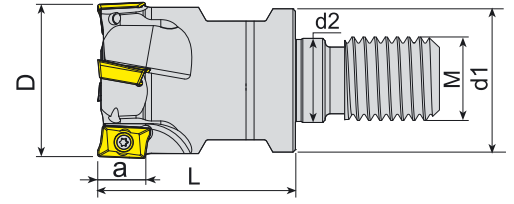

| Takım Kodu Ordering Code | Stok Stock | Takım Ölçüleri (mm) Dimension (mm) | | | | | | | Kesici Uç Insert | Yedek Parçaları Spare Parts | |
|------------------------------|---------------|---------------------------------------|---|-------|-----|----|------|----|---------------------|--------------------------------|--------------------------|
| | | D | Z | d1 | M | L | d2 | a | | Sıkma Vidası Screw | Tork Anahtar Torx Key |
| AEM90-AP10-D16-M08-L30-Z02-H | ● | 16 | 2 | 14.75 | M08 | 30 | 8.5 | 10 | AP. 1003.. | 3008-M2.5x6 | 80-T08 |
| AEM90-AP10-D20-M10-L30-Z03-H | ● | 20 | 3 | 18 | M10 | 30 | 10.5 | 10 | | | |
| AEM90-AP10-D25-M12-L35-Z03-H | ● | 25 | 3 | 21 | M12 | 35 | 12.5 | 10 | | | |
| AEM90-AP10-D32-M16-L35-Z04-H | ● | 32 | 4 | 29 | M16 | 35 | 17 | 10 | | | |
| AEM90-AP10-D40-M16-L43-Z05-H | ● | 40 | 5 | 29 | M16 | 43 | 17 | 10 | | | |
| AEM90-AP10-D42-M16-L43-Z05-H | ● | 42 | 5 | 29 | M16 | 43 | 17 | 10 | | | |
| AEM90-AP11-D16-M08-L30-Z02-H | ● | 16 | 2 | 14.75 | M08 | 30 | 8.5 | 11 | AP. 11T3.. | | |
| AEM90-AP11-D20-M10-L30-Z03-H | ● | 20 | 3 | 18 | M10 | 30 | 10.5 | 11 | | | |
| AEM90-AP16-D25-M12-L43-Z02-H | ● | 25 | 2 | 21 | M12 | 43 | 12.5 | 16 | AP. 1604.. | 1515-M4x9 | 80-T15 |
| AEM90-AP16-D32-M16-L43-Z03-H | ● | 32 | 3 | 29 | M16 | 43 | 17 | 16 | | | |
| AEM90-AP16-D40-M16-L43-Z04-H | ● | 40 | 4 | 29 | M16 | 43 | 17 | 16 | | | |

R: Sağ/Right L: Sol/Left ● Stokta/In Stock ○ Stokta Yok/Non Stock Item
ISO Ucuna Uygundur. / Compatible with ISO Insert.

Sipariş Örneği/Ordering Example : 1 ad./pcs. AEM90-AD1505D-D25-M12-L43-Z02-H
Kesme Hesabı : S 211 / Cutting Calculation : P 211

➤ S-SİSTEM MODÜLER PARMAK FREZELER
S-SYSTEM MODULAR END MILLS (SCREW TYPE TOOLS)

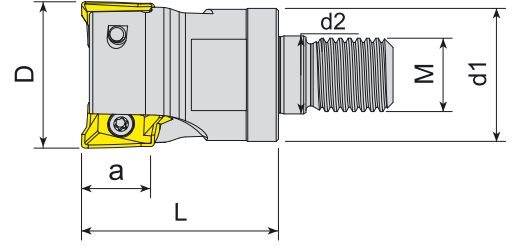

| Takım Kodu Ordering Code | Stok Stock | Takım Ölçüleri (mm) Dimension (mm) | | | | | | | Kesici Uç Insert | Yedek Parçaları Spare Parts | |
|--------------------------------|---------------|---------------------------------------|---|-------|-----|----|------|----|---------------------|--------------------------------|--------------------------|
| | | D | Z | d1 | M | L | d2 | a | | Sıkma Vidası Screw | Tork Anahtar Torx Key |
| AEM90-AX1235-D16-M08-L30-Z02-H | ● | 16 | 2 | 14.75 | M08 | 30 | 8.5 | 10 | | | |
| AEM90-AX1235-D20-M10-L30-Z03-H | ● | 20 | 3 | 18 | M10 | 30 | 10.5 | 10 | | | |
| AEM90-AX1235-D25-M12-L35-Z04-H | ● | 25 | 4 | 21 | M12 | 35 | 12.5 | 10 | | | |
| AEM90-AX1705-D25-M12-L43-Z02-H | ● | 25 | 2 | 21 | M12 | 43 | 12.5 | 14 | | | |
| AEM90-AX1705-D32-M16-L43-Z02-H | ● | 32 | 2 | 29 | M16 | 43 | 17 | 14 | | | |

SMTM Ucuna Uygun. / Compatiple with SMTM Insert.

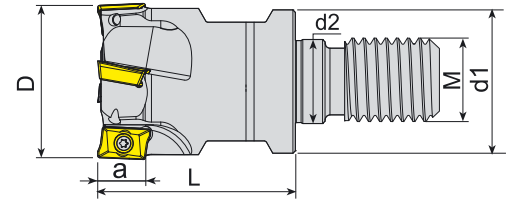

| Takım Kodu Ordering Code | Stok Stock | Takım Ölçüleri (mm) Dimension (mm) | | | | | | | Kesici Uç Insert | Yedek Parçaları Spare Parts | |
|---------------------------------|---------------|---------------------------------------|---|-------|-----|----|------|----|---------------------|--------------------------------|--------------------------|
| | | D | Z | d1 | M | L | d2 | a | | Sıkma Vidası Screw | Tork Anahtar Torx Key |
| AEM90-R390.11-D16-M08-L30-Z02-H | ● | 16 | 2 | 14.75 | M08 | 30 | 8.5 | 10 | | | |
| AEM90-R390.11-D20-M10-L30-Z03-H | ● | 20 | 3 | 18 | M10 | 30 | 10.5 | 10 | | | |
| AEM90-R390.11-D25-M12-L35-Z03-H | ● | 25 | 3 | 21 | M12 | 35 | 12.5 | 10 | | | |
| AEM90-R390.11-D32-M16-L43-Z04-H | ● | 32 | 4 | 29 | M16 | 43 | 17 | 10 | | | |

R: Sağ/Right L: Sol/Left ● Stokta/In Stock ○ Stokta Yok/Non Stock Item
SNDVK Ucuna Uygun. / Compatiple with SNDVK Insert.

Sipariş Örneği/Ordering Example : 1 ad./pcs. AEM90-AX1235-D16-M08-L30-Z02-H
Kesme Hesabı : S 211 / Cutting Calculation : P 211

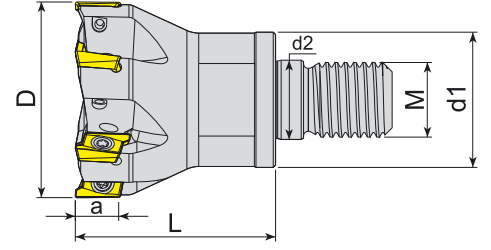

| Takım Kodu Ordering Code | Stok Stock | Takım Ölçüleri (mm) Dimension (mm) | | | | | | | Kesici Uç Insert | Yedek Parçaları Spare Parts | |
|------------------------------|---------------|---------------------------------------|---|----|-----|----|------|----|---------------------|--------------------------------|--------------------------|
| | | D | Z | d1 | M | L | d2 | a | | Sıkma Vidası Screw | Tork Anahtar Torx Key |
| AEM90-RT10-D25-M12-L30-Z04-H | ● | 25 | 4 | 21 | M12 | 30 | 12.5 | 10 | RT 1003.. | 3008-M2.5x6 | 80-T08 |
| AEM90-RT10-D32-M16-L43-Z05-H | ● | 32 | 5 | 29 | M16 | 43 | 17 | 10 | | | |
| AEM90-RT10-D42-M16-L43-Z06-H | ● | 42 | 6 | 29 | M16 | 43 | 17 | 10 | | | |

SFTY Ucuna Uygunur. / Compatiple with SFTY Insert.

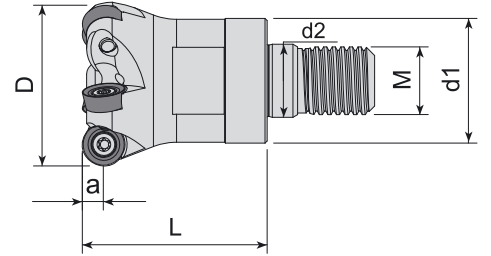

| Takım Kodu Ordering Code | Stok Stock | Takım Ölçüleri (mm) Dimension (mm) | | | | | | | Kesici Uç Insert | Yedek Parçaları Spare Parts | |
|-------------------------------|---------------|---------------------------------------|---|----|-----|----|------|---|---------------------|--------------------------------|--------------------------|
| | | D | Z | d1 | M | L | d2 | a | | Sıkma Vidası Screw | Tork Anahtar Torx Key |
| AEMR-RC10T3-D25-M12-L35-Z03-H | ● | 25 | 3 | 21 | M12 | 35 | 12.5 | 5 | RC.. 10T3.. | 1515-M4x9 | 80-T15 |
| AEMR-RC10T3-D32-M16-L43-Z04-H | ● | 32 | 4 | 29 | M16 | 43 | 17 | 5 | | | |
| AEMR-RC10T3-D40-M16-L43-Z05-H | ● | 40 | 5 | 29 | M16 | 43 | 17 | 5 | | | |

R: Sağ/Right L: Sol/Left ● Stokta/In Stock ○ Stokta Yok/Non Stock Item
ZCC Ucuna Uygunur. / Compatiple with ZCC Insert.

Sipariş Örneği/Ordering Example : 1 ad./pcs. AEM90-RT10-D25-M12-L30-Z04-H
Kesme Hesabı : S 211 / Cutting Calculation : P 211

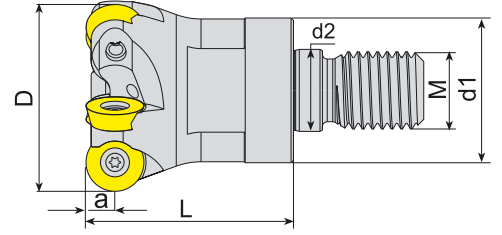

| Takım Kodu Ordering Code | Stok Stock | Takım Ölçüleri (mm) Dimension (mm) | | | | | | | Kesici Uç Insert | Yedek Parçaları Spare Parts | |
|-------------------------------|---------------|---------------------------------------|---|----|-----|----|------|-----|---------------------|--------------------------------|--------------------------|
| | | D | Z | d1 | M | L | d2 | a | | Sıkma Vidası Screw | Tork Anahtar Torx Key |
| AEMR-RD0702-D15-M08-L23-Z02-H | ● | 15 | 2 | 13 | M08 | 23 | 8.5 | 3.5 | RD.. 0702 | 3008-M2.5x6 | 80-T08 |
| AEMR-RD0702-D16-M08-L23-Z02-H | ● | 16 | 2 | 13 | M08 | 23 | 8.5 | 3.5 | | | |
| AEMR-RD0702-D20-M10-L30-Z04-H | ● | 20 | 4 | 18 | M10 | 30 | 10.5 | 3.5 | | | |
| AEMR-RD0702-D25-M12-L35-Z05-H | ● | 25 | 5 | 21 | M12 | 35 | 12.5 | 3.5 | | | |
| AEMR-RD0702-D30-M16-L42-Z05-H | ● | 30 | 5 | 29 | M16 | 42 | 17 | 3.5 | | | |
| AEMR-RD0702-D32-M16-L43-Z05-H | ● | 32 | 5 | 29 | M16 | 43 | 17 | 3.5 | | | |
| AEMR-RD0702-D35-M16-L42-Z06-H | ● | 35 | 6 | 29 | M16 | 42 | 17 | 3.5 | | | |
| AEMR-RD0702-D42-M16-L43-Z05-H | ● | 42 | 5 | 29 | M16 | 43 | 17 | 3.5 | | | |
| AEMR-RD0702-D42-M16-L43-Z07-H | ● | 42 | 7 | 29 | M16 | 43 | 17 | 3.5 | | | |
| AEMR-RD08T2-D16-M08-L23-Z02-H | ● | 16 | 2 | 13 | M08 | 23 | 8.5 | 4 | RD.. 08T2 | 3008-M2.5x6 | 80-T08 |
| AEMR-RD08T2-D20-M10-L30-Z03-H | ● | 20 | 3 | 18 | M10 | 30 | 10.5 | 4 | | | |
| AEMR-RD08T2-D25-M12-L35-Z04-H | ● | 25 | 4 | 21 | M12 | 35 | 12.5 | 4 | | | |
| AEMR-RD0803-D16-M08-L23-Z02-H | ● | 16 | 2 | 13 | M08 | 23 | 8.5 | 4 | RD.. 0803 | 1008-M3x6 | 80-T15 |
| AEMR-RD0803-D20-M10-L30-Z03-H | ● | 20 | 3 | 18 | M10 | 30 | 10.5 | 4 | | 1008-M3x8 | |
| AEMR-RD0803-D25-M12-L35-Z04-H | ● | 25 | 4 | 21 | M12 | 35 | 12.5 | 4 | | | |
| AEMR-RD1003-D20-M10-L30-Z02-H | ● | 20 | 2 | 18 | M10 | 30 | 10.5 | 5 | RD.. 1003 | 4015-M3.5x9 | 80-T15 |
| AEMR-RD1003-D25-M12-L35-Z02-H | ● | 25 | 2 | 21 | M12 | 35 | 12.5 | 5 | | | |
| AEMR-RD1003-D25-M12-L35-Z03-H | ● | 25 | 3 | 21 | M12 | 35 | 12.5 | 5 | | | |
| AEMR-RD1003-D30-M16-L43-Z04-H | ● | 30 | 4 | 29 | M16 | 43 | 17 | 5 | | | |
| AEMR-RD1003-D32-M16-L43-Z04-H | ● | 32 | 4 | 29 | M16 | 43 | 17 | 5 | | | |
| AEMR-RD1003-D35-M16-L43-Z04-H | ● | 35 | 4 | 29 | M16 | 43 | 17 | 5 | | | |
| AEMR-RD1003-D40-M16-L43-Z05-H | ● | 40 | 5 | 29 | M16 | 43 | 17 | 5 | | | |
| AEMR-RD1003-D42-M16-L43-Z05-H | ● | 42 | 5 | 29 | M16 | 43 | 17 | 5 | | | |
| AEMR-RD12T3-D24-M12-L35-Z02-H | ● | 24 | 2 | 21 | M12 | 35 | 12.5 | 6 | | | |
| AEMR-RD12T3-D25-M12-L35-Z02-H | ● | 25 | 2 | 21 | M12 | 35 | 12.5 | 6 | | | |
| AEMR-RD12T3-D32-M16-L43-Z03-H | ● | 32 | 3 | 29 | M16 | 43 | 17 | 6 | | | |
| AEMR-RD12T3-D35-M16-L43-Z03-H | ● | 35 | 3 | 29 | M16 | 43 | 17 | 6 | | | |
| AEMR-RD12T3-D35-M16-L43-Z04-H | ● | 35 | 4 | 29 | M16 | 43 | 17 | 6 | | | |
| AEMR-RD12T3-D40-M16-L43-Z04-H | ● | 40 | 4 | 29 | M16 | 43 | 17 | 6 | | | |
| AEMR-RD12T3-D42-M16-L43-Z05-H | ● | 42 | 5 | 29 | M16 | 43 | 17 | 6 | RD.. 1204 | 4015-M3.5x9 | 80-T15 |
| AEMR-RD1204-D32-M16-L43-Z03-H | ● | 32 | 3 | 29 | M16 | 43 | 17 | 6 | | | |
| AEMR-RD1204-D42-M16-L43-Z04-H | ● | 42 | 4 | 29 | M16 | 43 | 17 | 6 | RD.. 1604 | 1515-M4.5X11 | 80-T15 |
| AEMR-RD1604-D32-M16-L43-Z02-H | ● | 32 | 2 | 29 | M16 | 43 | 17 | 8 | | | |
| AEMR-RD1604-D40-M16-L43-Z02-H | ● | 40 | 2 | 29 | M16 | 43 | 17 | 8 | | | |
| AEMR-RD1604-D42-M16-L43-Z03-H | ● | 42 | 3 | 29 | M16 | 43 | 17 | 8 | | | |

R: Sağ/Right L: Sol/Left ● Stokta/In Stock ○ Stokta Yok/Non Stock Item
ISO Ucuna Uygunudur. / Compatible with ISO Insert.

Sipariş Örneği/Ordering Example : 1 ad./pcs. AEMR-RD0702-D15-M08-L23-Z02-H
Kesme Hesabı : S 211 / Cutting Calculation : P 211

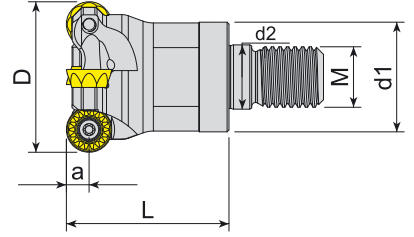

| Takım Kodu Ordering Code | Stok Stock | Takım Ölçüleri (mm) Dimension (mm) | | | | | | | Kesici Uç Insert | Yedek Parçaları Spare Parts | |
|--------------------------------|---------------|---------------------------------------|---|----|-----|----|------|---|---------------------|--------------------------------|--------------------------|
| | | D | Z | d1 | M | L | d2 | a | | Sıkma Vidası Screw | Tork Anahtar Torx Key |
| AEMR-RP08T2M-D20-M10-L30-Z02-H | ● | 20 | 2 | 18 | M10 | 30 | 10.5 | 4 | | 3008-M2.5x6 | 80-T08 |
| AEMR-RP10T3M-D25-M12-L35-Z02-H | ● | 25 | 2 | 21 | M12 | 35 | 12.5 | 5 | | 4015-M3.5x9 | 80-T15 |
| AEMR-RP1204M-D32-M16-L43-Z03-H | ● | 32 | 3 | 29 | M16 | 43 | 17 | 6 | | 1515-M4x9 | |
| AEMR-RP1204M-D40-M16-L43-Z04-H | ● | 40 | 4 | 29 | M16 | 43 | 17 | 6 | | | |

MTSBH Ucuna Uygundur. / Compatiple with MTSBH Insert.

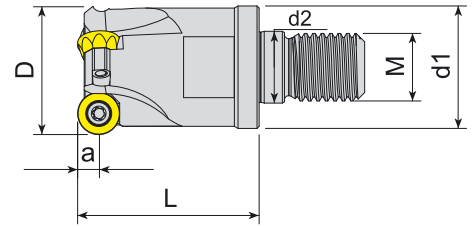

| Takım Kodu Ordering Code | Stok Stock | Takım Ölçüleri (mm) Dimension (mm) | | | | | | | Kesici Uç Insert | Yedek Parçaları Spare Parts | |
|-------------------------------|---------------|---------------------------------------|---|----|-----|----|------|---|---------------------|--------------------------------|--------------------------|
| | | D | Z | d1 | M | L | d2 | a | | Sıkma Vidası Screw | Tork Anahtar Torx Key |
| AEMR-QP10T3-D25-M12-L35-Z02-H | ● | 25 | 2 | 21 | M12 | 35 | 12.5 | 5 | | 4015-M3.5x9 | 80-T15 |
| AEMR-QP10T3-D32-M16-L43-Z03-H | ● | 32 | 3 | 29 | M16 | 43 | 17 | 5 | | | |

R: Sağ/Right L: Sol/Left ● Stokta/In Stock ○ Stokta Yok/Non Stock Item
SMTM Ucuna Uygundur. / Compatiple with SMTM Insert.



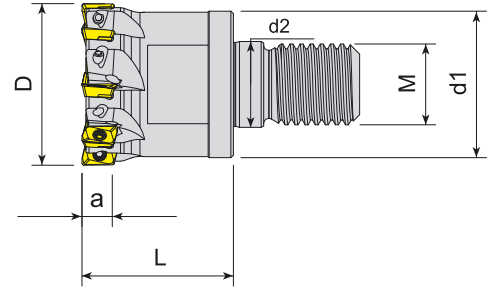



Sipariş Örneği/Ordering Example : 1 ad./pcs. AEMR-RP08T2M-D20-M10-L30-Z02-H
Kesme Hesabı : S 211 / Cutting Calculation : P 211

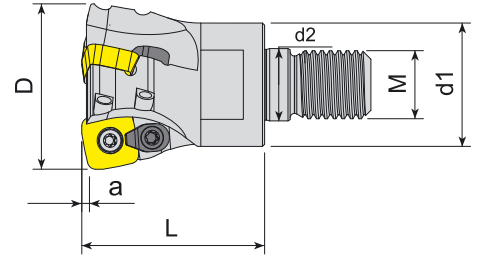

| Takım Kodu Ordering Code | Stok Stock | Takım Ölçüleri (mm) Dimension (mm) | | | | | | | Kesici Uç Insert | Yedek Parçaları Spare Parts | | |
|-------------------------------|---------------|---------------------------------------|---|-------|-----|----|------|---|--|--|---|--|
| | | D | Z | d1 | M | L | d2 | a | | Sıkma Vidası Screw | Tork Anahtar Torx Key | |
| AHFM-ED0702-D12-M06-L20-Z03 | ● | 12 | 3 | 10 | M06 | 20 | 6.5 | 6 |  EDMT 0702 JDMT 070204 |  3006-M1.8x4 |  80-T06 | |
| AHFM-ED0702-D16-M08-L25-Z04-H | ● | 16 | 4 | 14.75 | M08 | 25 | 8.5 | 6 | | | | |
| AHFM-ED0702-D20-M10-L30-Z05-H | ● | 20 | 5 | 18 | M10 | 30 | 10.5 | 6 | | | | |
| AHFM-ED0702-D25-M12-L30-Z06-H | ● | 25 | 6 | 21 | M12 | 30 | 12.5 | 6 | | | | |
| AHFM-ED0702-D32-M16-L30-Z08-H | ● | 32 | 8 | 29 | M16 | 30 | 17 | 6 | | | | |

HTCH Ucuna Uygun. / Compatible with HTCH Insert.

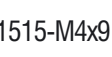

| Takım Kodu Ordering Code | Stok Stock | Takım Ölçüleri (mm) Dimension (mm) | | | | | | | Kesici Uç Insert | Yedek Parçaları Spare Parts | | | |
|--------------------------------|---------------|---------------------------------------|---|------|-----|----|------|-----|---|---|---|---|---|
| | | D | Z | d1 | M | L | d2 | a | | Sıkma Vidası Screw | Baskı Parçası Wedge Clamp | Baskı Vidası Clamp Screw | Tork Anahtar Torx Key |
| AHFMC-SD09T3-D22-M12-L30-Z02-H | ● | 22 | 2 | 21.5 | M12 | 30 | 12.5 | 1.4 |  SD.. 09T3.. |  4015-M3.5x9 |  ACK-15 |  1015-M3.5x11 |  80-T15 |
| AHFMC-SD09T3-D25-M12-L30-Z02-H | ● | 25 | 2 | 21.5 | M12 | 30 | 12.5 | 1.4 | | | | | |
| AHFMC-SD09T3-D32-M16-L43-Z03-H | ● | 32 | 3 | 29 | M16 | 43 | 17 | 1.4 | | | | | |
| AHFMC-SD09T3-D35-M16-L43-Z03-H | ● | 35 | 3 | 29 | M16 | 43 | 17 | 1.4 | | | | | |
| AHFMC-SD09T3-D40-M16-L43-Z04-H | ● | 40 | 4 | 29 | M16 | 43 | 17 | 1.4 | | | | | |
| AHFMC-SD1204-D32-M16-L43-Z02-H | ● | 32 | 2 | 29 | M16 | 43 | 17 | 1.8 |  SD.. 1204.. |  1515-M4x9 | | | |
| AHFMC-SD1204-D40-M16-L43-Z03-H | ● | 40 | 3 | 29 | M16 | 43 | 17 | 1.8 | | | | | |

R: Sağ/Right L: Sol/Left ● Stokta/In Stock ○ Stokta Yok/Non Stock Item
ZCC Ucuna Uygun. / Compatible with ZCC Insert.

Sipariş Örneği/Ordering Example : 1 ad./pcs. AHFM-ED0702-D12-M06-L20-Z03
Kesme Hesabı : S 211 / Cutting Calculation : P 211

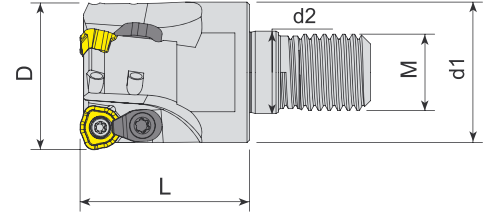

| Takım Kodu Ordering Code | Stok Stock | Takım Ölçüleri (mm) Dimension (mm) | | | | | | | Kesici Uç Insert | Yedek Parçaları Spare Parts | | | |
|--------------------------------|---------------|---------------------------------------|---|----|-----|----|------|---|---------------------|--------------------------------|------------------------------|-----------------------------|--------------------------|
| | | D | Z | d1 | M | L | d2 | a | | Sıkma Vidası Screw | Baskı Parçası Wedge Clamp | Baskı Vidası Clamp Screw | Tork Anahtar Torx Key |
| AHFMC-WD0804-D25-M12-L35-Z02-H | ● | 25 | 2 | 21 | M12 | 35 | 12.5 | - | WDMT 0804.. | | | | |
| AHFMC-WD0804-D32-M16-L35-Z03-H | ● | 32 | 3 | 29 | M16 | 35 | 17 | - | | | | | |

SMTM Ucuna Uygundur. / Compatiple with SMTM Insert.

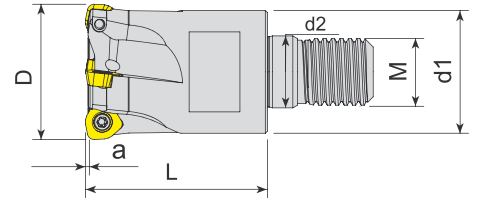

| Takım Kodu Ordering Code | Stok Stock | Takım Ölçüleri (mm) Dimension (mm) | | | | | | | Kesici Uç Insert | Yedek Parçaları Spare Parts | | | |
|---------------------------------|---------------|---------------------------------------|---|----|-----|----|------|-----|---------------------|--------------------------------|------------------------------|-----------------------------|--------------------------|
| | | D | Z | d1 | M | L | d2 | a | | Sıkma Vidası Screw | Baskı Parçası Wedge Clamp | Baskı Vidası Clamp Screw | Tork Anahtar Torx Key |
| AHFMC-WD0503D-D20-M10-L30-Z02-H | ● | 20 | 2 | 18 | M10 | 30 | 10.5 | - | WDMT 0503.. | | | | |
| AHFMC-WD0503D-D25-M12-L35-Z03-H | ● | 25 | 3 | 21 | M12 | 35 | 12.5 | - | | | | | |
| AHFMC-WD0503D-D32-M16-L43-Z04-H | ● | 32 | 4 | 29 | M16 | 43 | 17 | - | WDHW 06T3.. | | | | |
| AHFMC-WD06T3D-D35-M16-L43-Z03-H | ● | 35 | 3 | 29 | M16 | 43 | 17 | 1.5 | | | | | |

R: Sağ/Right L: Sol/Left ● Stokta/In Stock ○ Stokta Yok/Non Stock Item
DJT Ucuna Uygundur. / Compatiple with DJT Insert.

Sipariş Örneği/Ordering Example : 1 ad./pcs. AHFMC-WD0804-D25-M12-L35-Z02-H
Kesme Hesabı : S 211 / Cutting Calculation : P 211

> S-SİSTEM HIZLI İLERLEMELİ MODÜLER PARMAK FREZELER
S-SYSTEM MODULAR (SCREW TYPE) HIGHFEED END MILLS

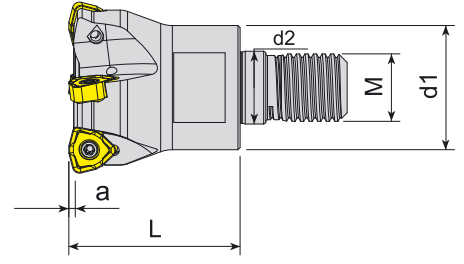







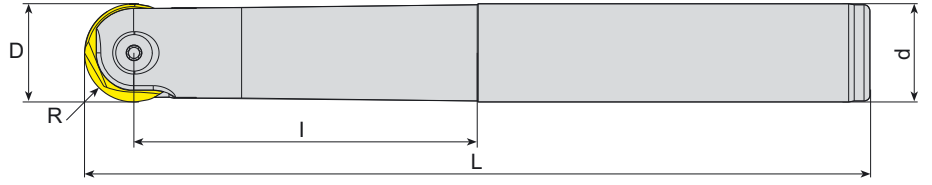

| Takım Kodu Ordering Code | Stok Stock | Takım Ölçüleri (mm) Dimension (mm) | | | | | | | Kesici Uç Insert | Yedek Parçaları Spare Parts | |
|-------------------------------|---------------|---------------------------------------|---|----|-----|----|----|-----|---|---|---|
| | | D | Z | d1 | M | L | d2 | a | | Sıkma Vidası Screw | Tork Anahtar Torx Key |
| AHFM-WN09T3-D32-M16-L40-Z03-H | ● | 32 | 3 | 29 | M16 | 40 | 17 | 1.5 |  |  |  |
| AHFM-WN09T3-D40-M16-L40-Z04-H | ● | 40 | 4 | 29 | M16 | 40 | 17 | 1.5 | | | |

R: Sağ/Right L: Sol/Left ● Stokta/In Stock ○ Stokta Yok/Non Stock Item
KRLY Ucuna Uygunudur. / Compatible with KRLY Insert.

Sipariş Örneği/Ordering Example : 1 ad./pcs. AHFM-WN09T3-D32-M16-L40-Z03-H
Kesme Hesabı : S 211 / Cutting Calculation : P 211





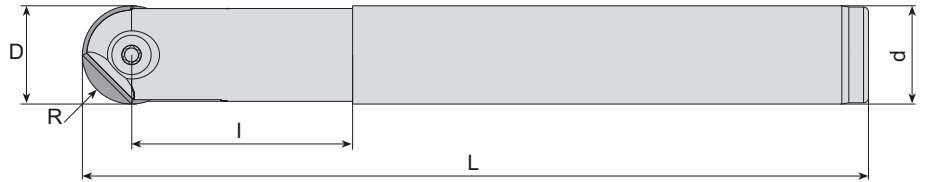

| Takım Kodu Ordering Code | Stok Stock | Takım Ölçüleri (mm) Dimension (mm) | | | | | Kesici Uç Insert | Yedek Parçaları Spare Parts | |
|-----------------------------|---------------|---------------------------------------|------|----|-----|-----|--|--------------------------------|----------------|
| | | D | R | d | L | l | | Sıkma Vidası Screw | Anahtar Key |
| APMR-P3208-D08-C10-L110 | ● | 8 | 4 | 10 | 110 | 25 |  | 1208-M3x7 | 80-T08 |
| APMR-P3210-D10-C12-L130 | ● | 10 | 5 | 12 | 130 | 30 |  | 1215-M4x0.5x9 | 80-T15 |
| APMR-P3212-D12-C12-L130 | ● | 12 | 6 | 12 | 130 | 32 |  | 1220-M5x0.5x9 | 80-T20 |
| APMR-P3216-D16-C16-L175 | ● | 16 | 8 | 16 | 175 | 60 |  | 1220-M5x0.5x12 | |
| APMR-P3220-D20-C20-L200 | ● | 20 | 10 | 20 | 200 | 100 |  | 1220-M5x0.5x15 | |
| APMR-P3225-D25-C25-L200 | ● | 25 | 12.5 | 25 | 200 | 100 |  | 1220-M6x0.75x20 | AAL-05-4 |
| APMR-P3232-D32-C32-L200 | ● | 32 | 16 | 32 | 200 | 100 |  | 1204-M8x0.75x26 | |

WLTR Ucuna Uygun. / Compatible with WLTR Insert.



| Takım Kodu Ordering Code | Stok Stock | Takım Ölçüleri (mm) Dimension (mm) | | | | | Kesici Uç Insert | Yedek Parçaları Spare Parts | |
|-----------------------------|---------------|---------------------------------------|----|----|-----|----|--|--------------------------------|--------------------------|
| | | D | R | d | L | l | | Sıkma Vidası Screw | Tork Anahtar Torx Key |
| APMR-R012-D12-C12-L120 | ● | 12 | 6 | 12 | 120 | 35 |  | 1215-M4x0.5x9 | 80-T15 |
| APMR-R012-D12-C16-L160 | ● | 12 | 6 | 16 | 160 | 50 |  | 1220-M5x0.5x12 | 80-T20 |
| APMR-R016-D16-C16-L160 | ● | 16 | 8 | 16 | 160 | 45 |  | 1220-M5x0.5x15 | |
| APMR-R016-D16-C20-L200 | ● | 16 | 8 | 20 | 200 | 65 | | | |
| APMR-R020-D20-C20-L160 | ● | 20 | 10 | 20 | 160 | 55 | | | |
| APMR-R020-D20-C25-L220 | ● | 20 | 10 | 25 | 220 | 80 | | | |

R: Sağ/Right L: Sol/Left ● Stokta/In Stock ○ Stokta Yok/Non Stock Item
ZCC Ucuna Uygun. / Compatible with ZCC Insert.

Sipariş Örneği/Ordering Example : 1 ad./pcs. APMR-P3208-D08-C10-L110
Kesme Hesabı : S 211 / Cutting Calculation : P 211

➤ VİDALI KÜRE UÇLU PARMAK FREZELER
BALL NOSE MODULAR (SCREW TYPE) END MILLS

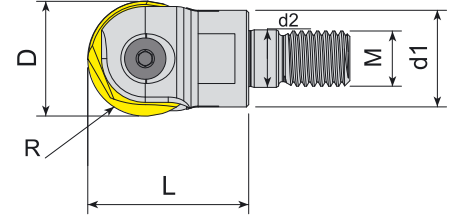

| Takım Kodu Ordering Code | Stok Stock | Takım Ölçüleri (mm) Dimension (mm) | | | | | | Kesici Uç Insert | Yedek Parçaları Spare Parts | |
|-----------------------------|---------------|---------------------------------------|------|----|-----|----|------|---------------------|--------------------------------|--------------------------|
| | | D | R | d1 | M | L | d2 | | Sıkma Vidası Screw | Tork Anahtar Torx Key |
| APMR-P3216-D16-M08-L25 | ● | 16 | 8 | 14 | M08 | 25 | 8.5 | | 1220-M5x0.5x12 | 80-T20 |
| APMR-P3220-D20-M10-L30 | ● | 20 | 10 | 18 | M10 | 30 | 10.5 | | 1220-M5x0.5x15 | |
| APMR-P3225-D25-M12-L35 | ● | 25 | 12.5 | 21 | M12 | 35 | 12.5 | | 1220-M6x0.75x20 | |

WLTR Ucuna Uygunur. / Compatiple with WLTR Insert.

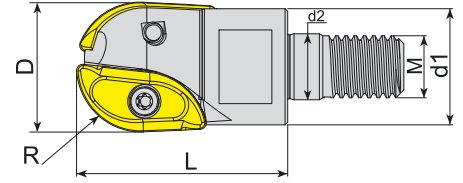

| Takım Kodu Ordering Code | Stok Stock | Takım Ölçüleri (mm) Dimension (mm) | | | | | | Kesici Uç Insert | Yedek Parçaları Spare Parts | |
|-----------------------------|---------------|---------------------------------------|------|------|-----|----|------|---------------------|--------------------------------|--------------------------|
| | | D | R | d1 | M | L | d2 | | Sıkma Vidası Screw | Tork Anahtar Torx Key |
| APMR-SWB225-D25-M12-L35 | ● | 25 | 12.5 | 23.5 | M12 | 35 | 12.5 | | 1020-M5x11 | 80-T20 |
| APMR-SWB232-D32-M16-L43 | ● | 32 | 16 | 30 | M16 | 43 | 17 | | | |

R: Sağ/Right L: Sol/Left ● Stokta/In Stock ○ Stokta Yok/Non Stock Item
DJT Ucuna Uygunur. / Compatiple with DJT Insert.

Sipariş Örneği/Ordering Example : 1 ad./pcs. APMR-P3216-D16-M08-L25
Kesme Hesabı : S 211 / Cutting Calculation : P 211

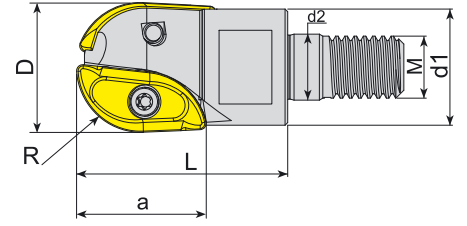

| Takım Kodu Ordering Code | Stok Stock | Takım Ölçüleri (mm) Dimension (mm) | | | | | | | Kesici Uç Insert | Yedek Parçaları Spare Parts | |
|-----------------------------|---------------|---------------------------------------|------|-------|-----|----|----|------|---------------------|--------------------------------|--------------------------|
| | | D | R | d1 | M | L | a | d2 | | Sıkma Vidası Screw | Tork Anahtar Torx Key |
| APMR-XP16-D16-M08-L25 | ● | 16 | 8 | 14.75 | M08 | 25 | 16 | 8.5 | | | |
| APMR-XP20-D20-M10-L30 | ● | 20 | 10 | 18 | M10 | 30 | 20 | 10.5 | XPHT 20R10T3 | 1510-M3.5x9 | 80-T10 |
| APMR-XP25-D25-M12-L35 | ● | 25 | 12.5 | 22 | M12 | 40 | 25 | 12.5 | XPHT 25R1204 | 1515-M4x9 | 80-T15 |

ZCC Ucuna Uygundur. / Compatible with ZCC Insert.

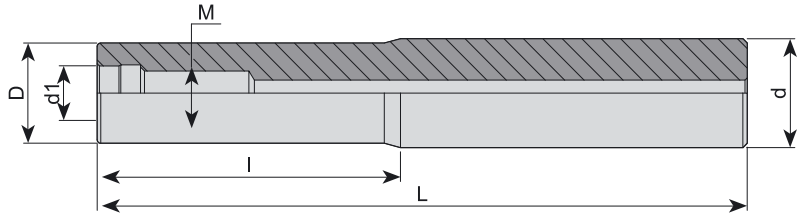

| Takım Kodu Ordering Code | Stok Stock | Takım Ölçüleri (mm) Dimension (mm) | | | | | |
|-----------------------------|---------------|---------------------------------------|-----|------|----|-----|-----|
| | | d | M | d1 | D | L | l |
| AVTT-D13-C16-M08-L100-H | ● | 16 | M08 | 8.5 | 13 | 100 | 40 |
| AVTT-D15-C16-M08-L130-H | ● | 16 | M08 | 8.5 | 15 | 130 | 70 |
| AVTT-D18-C20-M10-L130-H | ● | 20 | M10 | 10.5 | 18 | 130 | 70 |
| AVTT-D18-C20-M10-L160-H | ● | 20 | M10 | 10.5 | 18 | 160 | 80 |
| AVTT-D23-C25-M12-L150-H | ● | 25 | M12 | 12.5 | 23 | 150 | 70 |
| AVTT-D23-C25-M12-L200-H | ● | 25 | M12 | 12.5 | 23 | 200 | 100 |
| AVTT-D23-C25-M12-L250-H | ● | 25 | M12 | 12.5 | 23 | 250 | 150 |
| AVTT-D30-C32-M16-L150-H | ● | 32 | M16 | 17 | 30 | 150 | 70 |
| AVTT-D30-C32-M16-L200-H | ● | 32 | M16 | 17 | 30 | 200 | 100 |
| AVTT-D30-C32-M16-L250-H | ● | 32 | M16 | 17 | 30 | 250 | 150 |
| AVTT-D30-C32-M16-L300-H | ● | 32 | M16 | 17 | 30 | 300 | 200 |

R: Sağ/Right L: Sol/Left ● Stokta/In Stock ○ Stokta Yok/Non Stock Item

Sipariş Örneği/Ordering Example : 1 ad./pcs. AVTT-D13-C16-M08-L100-H
Kesme Hesabı : S 211 / Cutting Calculation : P 211

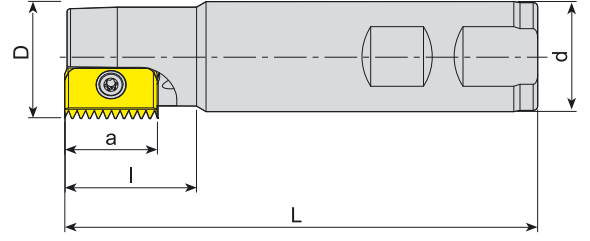

| Takım Kodu Ordering Code | Stok Stock | Takım Ölçüleri (mm) Dimension (mm) | | | | | | Kesici Uç Insert | Yedek Parçaları Spare Parts | |
|-----------------------------|---------------|---------------------------------------|---|----|-----|----|----|---------------------|--------------------------------|--------------------------|
| | | D | Z | d | L | l | a | | Sıkma Vidası Screw | Tork Anahtar Torx Key |
| ATM-C14-D14-W20-L100-Z01-H | ● | 14 | 1 | 20 | 100 | 25 | 14 | C14 | 3008-M2.5x6 | 80-T08 |
| ATM-C21-D18-W20-L100-Z01-H | ● | 18 | 1 | 20 | 100 | 30 | 21 | | 1515-M4x9 | |
| ATM-C21-D25-W20-L125-Z01-H | ● | 25 | 1 | 20 | 125 | 30 | 21 | C21 | 1515-M4x11 | 80-T15 |
| ATM-C21-D28-W25-L90-Z01-H | ● | 28 | 1 | 25 | 90 | 30 | 21 | | | |
| ATM-C21-D38-W32-L120-Z03-H | ● | 38 | 3 | 32 | 120 | 30 | 21 | | | |
| ATM-C21-D43-W32-L90-Z03-H | ● | 43 | 3 | 32 | 90 | 30 | 21 | C30 | 1020-M5x11 | 80-T20 |
| ATM-C30-D29-W25-L150-Z01-H | ● | 29 | 1 | 25 | 150 | 50 | 30 | | | |

CPT Ucuna Uygundur. / Compatible with CPT Insert.

➤ S-SİSTEM HELİS FREZELER
S-SYSTEM HELIX END MILL

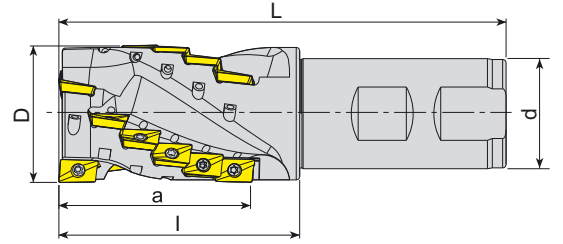
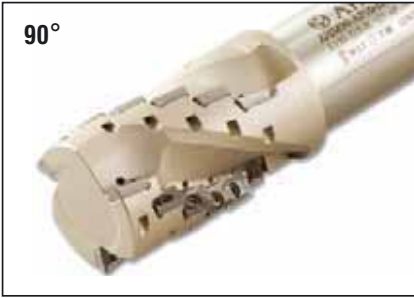

| Takım Kodu Ordering Code | Stok Stock | Takım Ölçüleri (mm) Dimension (mm) | | | | | | | Kesici Uç Insert | Yedek Parçaları Spare Parts | |
|---------------------------------|---------------|---------------------------------------|---------------------|----|----|----|----|-----|---------------------|--------------------------------|--------------------------|
| | | Z | | D | d | a | l | L | | Sıkma Vidası Screw | Tork Anahtar Torx Key |
| | | Toplam Total | Etkili Effective | | | | | | | | |
| AHM90-AP10-D20-W20-L087-Z0206-H | ● | 6 | 2 | 20 | 20 | 28 | 36 | 87 | AP. 1003.. | 3008-M2.5x6 | 80-T08 |
| AHM90-AP10-D25-W25-L105-Z0208-H | ● | 8 | 2 | 25 | 25 | 37 | 47 | 105 | | | |
| AHM90-AP10-D32-W32-L115-Z0315-H | ● | 15 | 3 | 32 | 32 | 46 | 54 | 115 | | | |
| AHM90-AP10-D40-W32-L130-Z0318-H | ● | 18 | 3 | 40 | 32 | 55 | 64 | 130 | | | |

R: Sağ/Right L: Sol/Left ● Stokta/In Stock ○ Stokta Yok/Non Stock Item
ISO Ucuna Uygundur. / Compatible with ISO Insert.

Sipariş Örneği/Ordering Example : 1 ad./pcs. AHM90-AP10-D20-W20-L087-Z0206-H
Kesme Hesabı : S 211 / Cutting Calculation : P 211

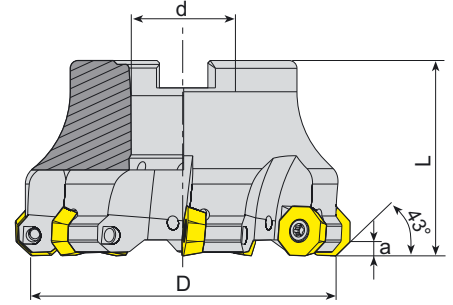

| Takım Kodu Ordering Code | Stok Stock | Takım Ölçüleri (mm) Dimension (mm) | | | | | Kesici Uç Insert | Yedek Parçaları Spare Parts | | |
|------------------------------|---------------|---------------------------------------|---|----|----|-----|---------------------|--------------------------------|--------------------------|---------------------------------|
| | | D | Z | d | L | a | | Sıkma Vidası Screw | Tork Anahtar Torx Key | Montaj Vidası Mounting Screw |
| AFM43-OD0504-D040-A16-Z04-H | ● | 40 | 4 | 16 | 40 | 3.5 | OD.. 0504.. | | | 2506-M8x30 |
| AFM43-OD0504-D050-A22-Z05-H | ● | 50 | 5 | 22 | 40 | 3.5 | | | | 2407-M10x30 |
| AFM43-OD0504-D063-A22-Z06-H | ● | 63 | 6 | 22 | 40 | 3.5 | | | | 2510-M12x35 |
| AFM43-OD0504-D080-A27-Z07-H | ● | 80 | 7 | 27 | 50 | 3.5 | | | | 2514-M16x35 |
| AFM43-OD0504-D0100-A32-Z08-H | ● | 100 | 8 | 32 | 50 | 3.5 | | | | |

WLTR Ucuna Uygundur. / Compatible with WLTR Insert.

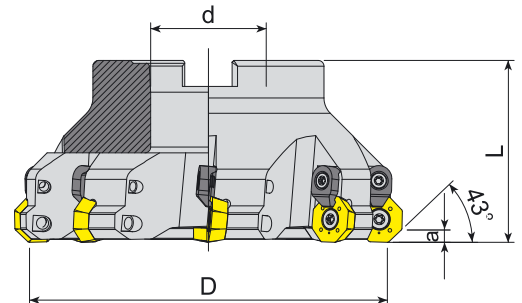

| Takım Kodu Ordering Code | Stok Stock | Takım Ölçüleri (mm) Dimension (mm) | | | | | Kesici Uç Insert | Yedek Parçaları Spare Parts | | | | | | | | |
|------------------------------|---------------|---------------------------------------|---|----|----|---|---------------------|--------------------------------|------------------------------|-----------------------------|--------------------------|---------------------------------|--------|------------|--------|-------------|
| | | D | Z | d | L | a | | Sıkma Vidası Screw | Baskı Parçası Wedge Clamp | Baskı Vidası Clamp Screw | Tork Anahtar Torx Key | Montaj Vidası Mounting Screw | | | | |
| AFM43C-OD0605-D080-A27-Z06-H | ● | 80 | 6 | 27 | 50 | 4 | OD.. 0605.. | | | | | 2510-M12x35 | | | | |
| AFM43C-OD0605-D100-A32-Z07-H | ● | 100 | 7 | 32 | 50 | 4 | | | | | | 1020-M5x11 | ACK-05 | 1515-M4x11 | 80-T20 | 2514-M16x35 |
| AFM43C-OD0605-D125-B40-Z08 | ● | 125 | 8 | 40 | 63 | 4 | | | | | | | | | | - |

R: Sağ/Right L: Sol/Left ● Stokta/In Stock ○ Stokta Yok/Non Stock Item
WLTR-LMN Ucuna Uygundur. / Compatible with WLTR-LMN Insert.

Sipariş Örneği/Ordering Example : 1 ad./pcs. AFM43-OD0504-D040-A16-Z04-H
Kesme Hesabı : S 211 / Cutting Calculation : P 211
Montaj Ölçüleri : S 209 / Mounting Reference : P 209

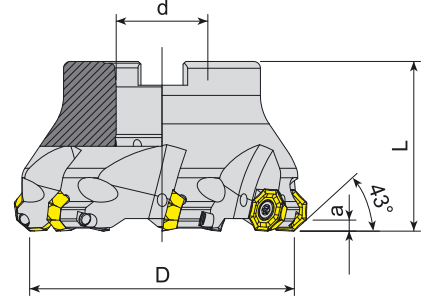

| Takım Kodu Ordering Code | Stok Stock | Takım Ölçüleri (mm) Dimension (mm) | | | | | Kesici Uç Insert | Yedek Parçaları Spare Parts | | |
|-----------------------------|---------------|---------------------------------------|---|----|----|---|---------------------|--------------------------------|--------------------------|---------------------------------|
| | | D | Z | d | L | a | | Sıkma Vidası Screw | Tork Anahtar Torx Key | Montaj Vidası Mounting Screw |
| AFM43-0F05T3-D050-A22-Z05-H | ● | 50 | 5 | 22 | 40 | 3 | OF.. 05T3.. | 1515-M4x9 | 80-T15 | 2407-M10x30 |
| AFM43-0F05T3-D063-A22-Z06-H | ● | 63 | 6 | 22 | 40 | 3 | | 1515-M4x11 | | |
| AFM43-0F05T3-D080-A27-Z07-H | ● | 80 | 7 | 27 | 50 | 3 | | 2510-M12x35 | | |

ISO Ucuna Uygunudur. / Compatible with ISO Insert.

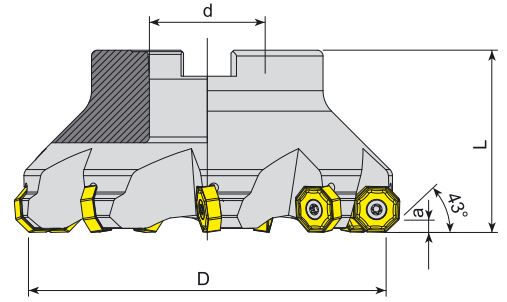

| Takım Kodu Ordering Code | Stok Stock | Takım Ölçüleri (mm) Dimension (mm) | | | | | Kesici Uç Insert | Yedek Parçaları Spare Parts | | |
|-----------------------------|---------------|---------------------------------------|---|----|----|---|---------------------|--------------------------------|--------------------------|---------------------------------|
| | | D | Z | d | L | a | | Sıkma Vidası Screw | Tork Anahtar Torx Key | Montaj Vidası Mounting Screw |
| AFM43-0N0604-D050-A22-Z05-H | ● | 50 | 5 | 22 | 40 | 4 | ON.. 0604.. | 1515-M4x11 | 80-T15 | 2508-M10x30 |
| AFM43-0N0604-D063-A22-Z06-H | ● | 63 | 6 | 22 | 40 | 4 | | | | |
| AFM43-0N0604-D080-A27-Z07-H | ● | 80 | 7 | 27 | 50 | 4 | | | | 2510-M12x35 |
| AFM43-0N0604-D100-A32-Z08-H | ● | 100 | 8 | 32 | 50 | 4 | | | | 2514-M16x35 |
| AFM43-0N0604-D125-B40-Z09 | ● | 125 | 9 | 40 | 63 | 4 | | | | - |

R: Sağ/Right L: Sol/Left ● Stokta/In Stock ○ Stokta Yok/Non Stock Item
ZCC Ucuna Uygunudur. / Compatible with ZCC Insert.

Sipariş Örneği/Ordering Example : 1 ad./pcs. AFM43-0N0604-D050-A22-Z05-H
Kesme Hesabı : S 211 / Cutting Calculation : P 211
Montaj Ölçüleri : S 209 / Mounting Reference : P 209

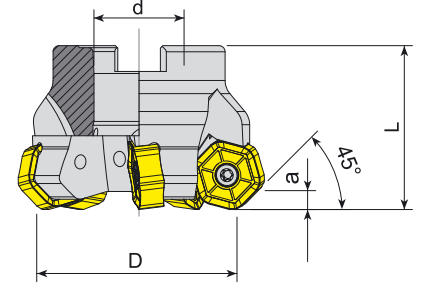

| Takım Kodu Ordering Code | Stok Stock | Takım Ölçüleri (mm) Dimension (mm) | | | | | Kesici Uç Insert | Yedek Parçaları Spare Parts | | |
|-----------------------------|---------------|---------------------------------------|---|----|----|-----|---------------------|--------------------------------|--------------------------|---------------------------------|
| | | D | Z | d | L | a | | Sıkma Vidası Screw | Tork Anahtar Torx Key | Montaj Vidası Mounting Screw |
| AFM45-HN0905-D050-A22-Z05-H | ● | 50 | 5 | 22 | 40 | 4.5 | HN.. 0905.. | 1515-M4x11 | 80-T15 | 2407-M10x30 |
| AFM45-HN0905-D063-A22-Z06-H | ● | 63 | 6 | 22 | 40 | 4.5 | | | | |
| AFM45-HN0905-D080-A27-Z07-H | ● | 80 | 7 | 27 | 50 | 4.5 | | | | |

WDA Ucuna Uygundur. / Compatible with WDA Insert.

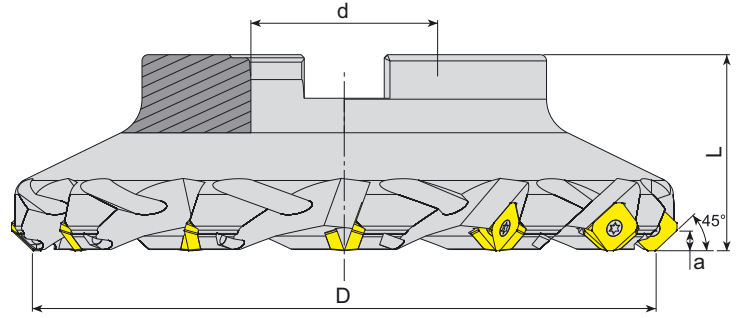

| Takım Kodu Ordering Code | Stok Stock | Takım Ölçüleri (mm) Dimension (mm) | | | | | Kesici Uç Insert | Yedek Parçaları Spare Parts | | |
|-----------------------------|---------------|---------------------------------------|----|----|----|---|----------------------------|--------------------------------|--------------------------|---------------------------------|
| | | D | Z | d | L | a | | Sıkma Vidası Screw | Tork Anahtar Torx Key | Montaj Vidası Mounting Screw |
| AFM45-SE12-D050-A22-Z04-H | ● | 50 | 4 | 22 | 40 | 6 | SE.. 12T3.. R245-12T3.. | 4015-M3.5x11 | 80-T15 | 2407-M10x30 |
| AFM45L-SE12-D050-A22-Z04-H | ● | 50 | 4 | 22 | 40 | 6 | | | | |
| AFM45-SE12-D063-A22-Z05-H | ● | 63 | 5 | 22 | 40 | 6 | | | | |
| AFM45L-SE12-D063-A22-Z05-H | ● | 63 | 5 | 22 | 40 | 6 | | | | 2510-M12x35 |
| AFM45-SE12-D080-A27-Z06-H | ● | 80 | 6 | 27 | 50 | 6 | | | | 2514-M16x35 |
| AFM45L-SE12-D080-A27-Z06-H | ● | 80 | 6 | 27 | 50 | 6 | | | | - |
| AFM45-SE12-D100-A32-Z07-H | ● | 100 | 7 | 32 | 50 | 6 | | | | - |
| AFM45-SE12-D125-B40-Z08 | ● | 125 | 8 | 40 | 63 | 6 | | | | - |
| AFM45-SE12-D160-C40-Z10 | ● | 160 | 10 | 40 | 63 | 6 | | | | - |
| AFM45-SE12-D200-C60-Z12 | ● | 200 | 12 | 60 | 63 | 6 | | | | - |

R: Sağ/Right L: Sol/Left ● Stokta/In Stock ○ Stokta Yok/Non Stock Item
ZCC-SNDVK Ucuna Uygundur. / Compatible with ZCC-SNDVK Insert.

Sipariş Örneği/Ordering Example : 1 ad./pcs. AFM45-HN0905-D050-A22-Z05-H
Kesme Hesabı : S 211 / Cutting Calculation : P 211
Montaj Ölçüleri : S 209 / Mounting Reference : P 209

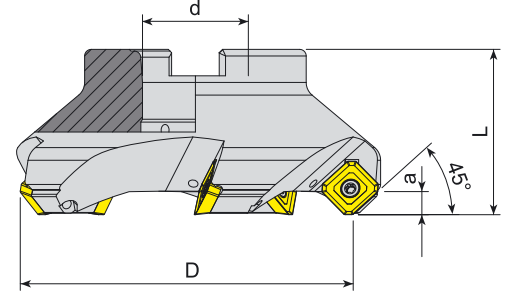

| Takım Kodu Ordering Code | Stok Stock | Takım Ölçüleri (mm) Dimension (mm) | | | | | Kesici Uç Insert | Yedek Parçaları Spare Parts | | |
|-----------------------------|---------------|---------------------------------------|---|----|----|---|---------------------|--------------------------------|--------------------------|---------------------------------|
| | | D | Z | d | L | a | | Sıkma Vidası Screw | Tork Anahtar Torx Key | Montaj Vidası Mounting Screw |
| AFM45-SE14M4-D063-A22-Z04-H | ● | 63 | 4 | 22 | 40 | 7 | SE.. 14M4.. | 4015-M3.5x11 | 80-T15 | 2407-M10x30 |
| AFM45-SE14M4-D080-A27-Z05-H | ● | 80 | 5 | 27 | 50 | 7 | | | | 2510-M12x35 |
| AFM45-SE14M4-D100-A32-Z05-H | ● | 100 | 5 | 32 | 50 | 7 | | | | 2514-M16x35 |
| AFM45-SE14M4-D125-B40-Z06 | ● | 125 | 6 | 40 | 63 | 7 | | | | - |
| AFM45-SE14M4-D160-C40-Z07 | ● | 160 | 7 | 40 | 63 | 7 | | | | - |

KRLY Ucuna Uygunudur. / Compatible with KRLY Insert.

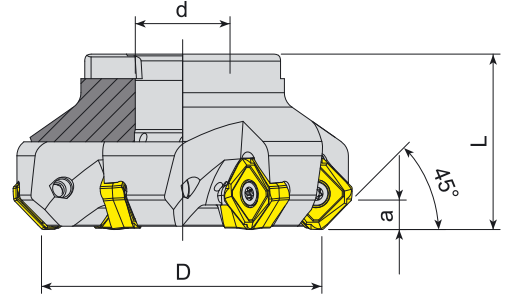

| Takım Kodu Ordering Code | Stok Stock | Takım Ölçüleri (mm) Dimension (mm) | | | | | Kesici Uç Insert | Yedek Parçaları Spare Parts | | |
|-----------------------------|---------------|---------------------------------------|---|----|----|-----|---------------------|--------------------------------|--------------------------|---------------------------------|
| | | D | Z | d | L | a | | Sıkma Vidası Screw | Tork Anahtar Torx Key | Montaj Vidası Mounting Screw |
| AFM45-SA1706-D080-A27-Z06-H | ● | 80 | 6 | 27 | 50 | 8.4 | SAKU 1706.. | 1020-M5x14 | 80-T20 | 2510-M12x35 |
| AFM45-SA1706-D100-A32-Z07-H | ● | 100 | 7 | 32 | 50 | 8.4 | | | | 2514-M16x35 |
| AFM45-SA1706-D125-B40-Z09 | ● | 125 | 9 | 40 | 63 | 8.4 | | | | - |

R: Sağ/Right L: Sol/Left ● Stokta/In Stock ○ Stokta Yok/Non Stock Item
CRTZT Ucuna Uygunudur. / Compatible with CRTZT Insert.

Sipariş Örneği/Ordering Example : 1 ad./pcs. AFM45-SE14M4-D063-A22-Z04-H
Kesme Hesabı : S 211 / Cutting Calculation : P 211
Montaj Ölçüleri : S 209 / Mounting Reference : P 209

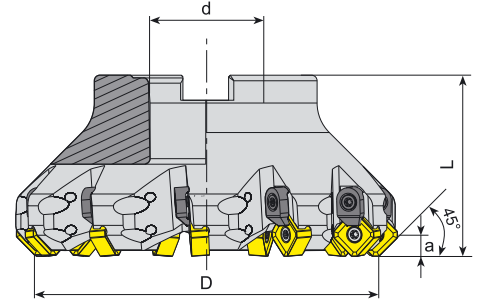

| Takım Kodu Ordering Code | Stok Stock | Takım Ölçüleri (mm) Dimension (mm) | | | | | Kesici Uç Insert | Yedek Parçaları Spare Parts | | | | | |
|-------------------------------|---------------|---------------------------------------|----|----|----|---|---------------------|--------------------------------|------------------------------|-----------------------------|--------------------------|---------------------------------|-------------|
| | | D | Z | d | L | a | | Sıkma Vidası Screw | Baskı Parçası Wedge Clamp | Baskı Vidası Clamp Screw | Tork Anahtar Torx Key | Montaj Vidası Mounting Screw | |
| AFM45C-SN1206-D050-A22-Z05-H | ● | 50 | 5 | 22 | 42 | 6 | SN.. 1206.. | 1515-M4x11 | ACK-05 | 1515-M4x11 | 80-T15 | 2407-M10x30 | |
| AFM45C-SN1206-D063-A22-Z07-H | ● | 63 | 7 | 22 | 42 | 6 | | | | | | | 2510-M12x35 |
| AFM45C-SN1206-D080-A27-Z08-H | ● | 80 | 8 | 27 | 52 | 6 | | | | | | | 2514-M16x35 |
| AFM45C-SN1206-D100-A32-Z10-H | ● | 100 | 10 | 32 | 52 | 6 | | | | | | | - |
| AFM45CL-SN1206-D100-A32-Z10-H | ● | 100 | 10 | 32 | 52 | 6 | | | | | | | - |
| AFM45C-SN1206-D125-B40-Z11 | ● | 125 | 11 | 40 | 65 | 6 | | | | | | | - |
| AFM45CL-SN1206-D125-B40-Z11 | ● | 125 | 11 | 40 | 65 | 6 | | | | | | | - |
| AFM45C-SN1206-D160-C40-Z12 | ● | 160 | 12 | 40 | 65 | 6 | | | | | | | - |
| AFM45C-SN1206-D200-C60-Z14 | ● | 200 | 14 | 60 | 65 | 6 | | | | | | | - |
| AFM45CL-SN1206-D200-C60-Z14 | ● | 200 | 14 | 60 | 65 | 6 | | | | | | | - |

ISO Ucuna Uygundur. / Compatible with ISO Insert.

WLTR ucu ile kullanılacaksa, sipariş verirken belirtilmelidir.
If will be used with WLTR insert, should be mentioned on order.

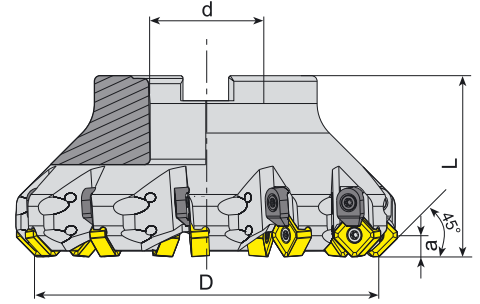

| Takım Kodu Ordering Code | Stok Stock | Takım Ölçüleri (mm) Dimension (mm) | | | | | Kesici Uç Insert | Yedek Parçaları Spare Parts | | | | | |
|-----------------------------|---------------|---------------------------------------|----|----|----|---|---------------------|--------------------------------|------------------------------|-----------------------------|--------------------------|---------------------------------|-------------|
| | | D | Z | d | L | a | | Sıkma Vidası Screw | Baskı Parçası Wedge Clamp | Baskı Vidası Clamp Screw | Tork Anahtar Torx Key | Montaj Vidası Mounting Screw | |
| AFM45C-SN122-D050-A22-Z05-H | ● | 50 | 5 | 22 | 42 | 6 | SNEG 1205.. | 1515-M4x11 | ACK-05 | 1515-M4x11 | 80-T15 | 2407-M10x30 | |
| AFM45C-SN122-D063-A22-Z06-H | ● | 63 | 6 | 22 | 42 | 6 | | | | | | | 2510-M12x35 |
| AFM45C-SN122-D080-A27-Z07-H | ● | 80 | 7 | 27 | 52 | 6 | | | | | | | 2514-M16x35 |
| AFM45C-SN122-D100-A32-Z09-H | ● | 100 | 9 | 32 | 52 | 6 | | | | | | | - |
| AFM45C-SN122-D125-B40-Z11 | ● | 125 | 11 | 40 | 65 | 6 | | | | | | | - |
| AFM45C-SN122-D160-C40-Z12 | ○ | 160 | 12 | 60 | 65 | 6 | | | | | | | - |
| AFM45C-SN122-D200-C60-Z14 | ● | 200 | 14 | 60 | 65 | 6 | | | | | | | - |

R: Sağ/Right L: Sol/Left ● Stokta/In Stock ○ Stokta Yok/Non Stock Item
ZCC Ucuna Uygundur. / Compatible with ZCC Insert.

Sipariş Örneği/Ordering Example : 1 ad./pcs. AFM45C-SN1206-D050-A22-Z04-H
Kesme Hesabı : S 211 / Cutting Calculation : P 211
Montaj Ölçüleri : S 209 / Mounting Reference : P 209

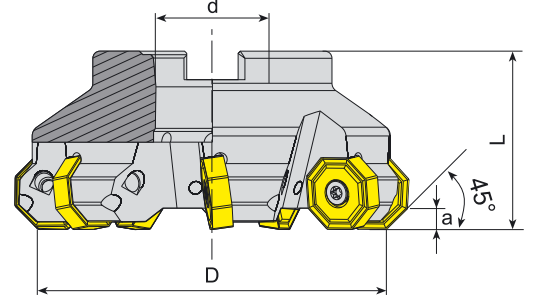

| Takım Kodu Ordering Code | Stok Stock | Takım Ölçüleri (mm) Dimension (mm) | | | | | Kesici Uç Insert | Yedek Parçaları Spare Parts | | |
|-----------------------------|---------------|---------------------------------------|----|----|----|---|---------------------|--------------------------------|--------------------------|---------------------------------|
| | | D | Z | d | L | a | | Sıkma Vidası Screw | Tork Anahtar Torx Key | Montaj Vidası Mounting Screw |
| AFM45-ON0806-D063-A22-Z05-H | ● | 63 | 5 | 22 | 40 | 4 | ON.. 0806.. | 1020-M5x11 | 80-T20 | 2508-M10x30 |
| AFM45-ON0806-D080-A27-Z06-H | ● | 80 | 6 | 27 | 50 | 4 | | | | 2510-M12x35 |
| AFM45-ON0806-D100-A32-Z07-H | ● | 100 | 7 | 32 | 50 | 4 | | | | 2514-M16x35 |
| AFM45-ON0806-D125-B40-Z08-H | ● | 125 | 8 | 40 | 63 | 4 | | | | - |
| AFM45-ON0806-D160-C40-Z10 | ● | 160 | 10 | 40 | 63 | 4 | | | | - |
| AFM45-ON0806-D200-C60-Z12 | ● | 200 | 12 | 60 | 63 | 4 | | | | - |

ISO Ucuna Uygundur. / Compatible with ISO Insert.

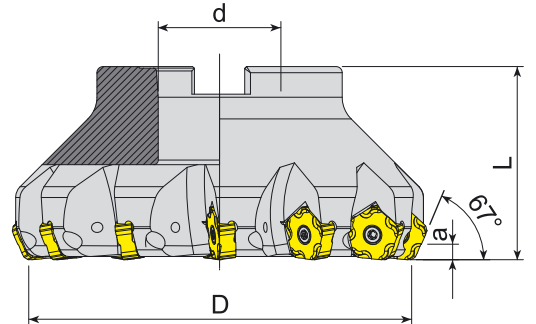

| Takım Kodu Ordering Code | Stok Stock | Takım Ölçüleri (mm) Dimension (mm) | | | | | Kesici Uç Insert | Yedek Parçaları Spare Parts | | |
|-----------------------------|---------------|---------------------------------------|----|----|----|---|---------------------|--------------------------------|--------------------------|---------------------------------|
| | | D | Z | d | L | a | | Sıkma Vidası Screw | Tork Anahtar Torx Key | Montaj Vidası Mounting Screw |
| AFM67-PN1105-D050-A22-Z05 | ● | 50 | 5 | 22 | 50 | 5 | PNEG 1105.. | 1515-M4x11 | 80-T15 | 2508-M10x30 |
| AFM67-PN1105-D063-A22-Z06 | ● | 63 | 6 | 22 | 50 | 5 | | | | 2510-M12x35 |
| AFM67-PN1105-D080-A27-Z08 | ● | 80 | 8 | 27 | 50 | 5 | | | | - |
| AFM67-PN1105-D100-B32-Z10 | ● | 100 | 10 | 32 | 50 | 5 | | | | - |
| AFM67-PN1105-D125-B40-Z12 | ● | 125 | 12 | 40 | 63 | 5 | | | | - |
| AFM67-PN1105-D160-C40-Z14 | ● | 160 | 14 | 40 | 63 | 5 | | | | - |

R: Sağ/Right L: Sol/Left ● Stokta/In Stock ○ Stokta Yok/Non Stock Item
ZCC Ucuna Uygundur. / Compatible with ZCC Insert.

Sipariş Örneği/Ordering Example : 1 ad./pcs. AFM67-PN1105-D050-A22-Z05
Kesme Hesabı : S 211 / Cutting Calculation : P 211
Montaj Ölçüleri : S 209 / Mounting Reference : P 209

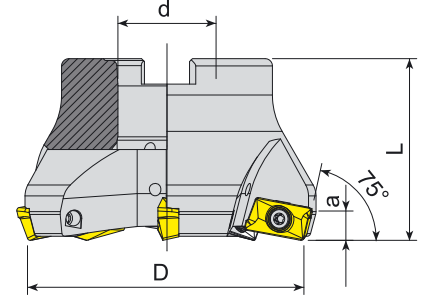

| Takım Kodu Ordering Code | Stok Stock | Takım Ölçüleri (mm) Dimension (mm) | | | | | Kesici Uç Insert | Yedek Parçaları Spare Parts | | |
|-----------------------------|---------------|---------------------------------------|---|----|----|---|---------------------|--------------------------------|--------------------------|---------------------------------|
| | | D | Z | d | L | a | | Sıkma Vidası Screw | Tork Anahtar Torx Key | Montaj Vidası Mounting Screw |
| AFM75-AP16-D063-A22-Z04-H | ● | 63 | 4 | 22 | 40 | 6 | AP. 1604.. | 1515-M4x11 | 80-T15 | 2508-M10x30 |
| AFM75-AP16-D080-A27-Z05-H | ● | 80 | 5 | 27 | 50 | 6 | | | | 2510-M12x35 |
| AFM75-AP16-D100-A32-Z06-H | ● | 100 | 6 | 32 | 50 | 6 | | | | 2514-M16x35 |
| AFM75-AP16-D125-B40-Z07 | ● | 125 | 7 | 40 | 63 | 6 | | | | - |

ISO Ucuna Uygundur. / Compatible with ISO Insert.

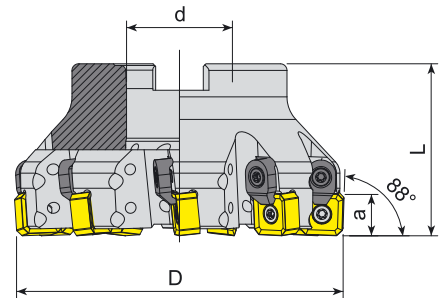

| Takım Kodu Ordering Code | Stok Stock | Takım Ölçüleri (mm) Dimension (mm) | | | | | Kesici Uç Insert | Yedek Parçaları Spare Parts | | | | |
|------------------------------|---------------|---------------------------------------|---|----|----|------|---------------------|--------------------------------|------------------------------|-----------------------------|--------------------------|---------------------------------|
| | | D | Z | d | L | a | | Sıkma Vidası Screw | Baskı Parçası Wedge Clamp | Baskı Vidası Clamp Screw | Tork Anahtar Torx Key | Montaj Vidası Mounting Screw |
| AFM88C-SN1206-D063-A22-Z06-H | ● | 63 | 6 | 22 | 40 | 11.5 | SN.. 1206.. | 1615-M4x11 | ACK-05 | 1515-M4x11 | 80-T15 | 2508-M10x30 |
| AFM88C-SN1206-D080-A27-Z07-H | ● | 80 | 7 | 27 | 50 | 11.5 | | | | | | 2510-M12x35 |
| AFM88C-SN1206-D100-A32-Z09-H | ● | 100 | 9 | 32 | 52 | 11.5 | | | | | | 2514-M16x35 |

R: Sağ/Right L: Sol/Left ● Stokta/In Stock ○ Stokta Yok/Non Stock Item
ISO Ucuna Uygundur. / Compatible with ISO Insert.

Sipariş Örneği/Ordering Example : 1 ad./pcs. AFM88C-SN1206-D063-A22-Z06-H
Kesme Hesabı : S 211 / Cutting Calculation : P 211
Montaj Ölçüleri : S 209 / Mounting Reference : P 209

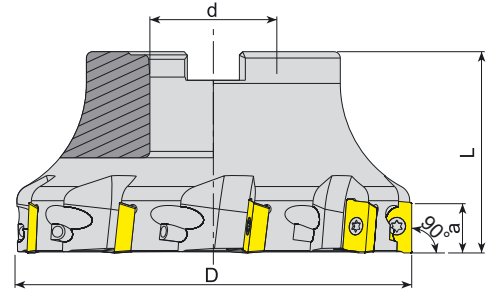

| Takım Kodu Ordering Code | Stok Stock | Takım Ölçüleri (mm) Dimension (mm) | | | | | Kesici Uç Insert | Yedek Parçaları Spare Parts | | |
|-----------------------------|---------------|---------------------------------------|---|----|----|----|---------------------|--------------------------------|--------------------------|---------------------------------|
| | | D | Z | d | L | a | | Sıkma Vidası Screw | Tork Anahtar Torx Key | Montaj Vidası Mounting Screw |
| AFM90-AD1505-D040-A16-Z04-H | ● | 40 | 4 | 16 | 40 | 15 | AD.. 1505.. | 1515-M4x11 | 80-T15 | 2506-M8x30 |
| AFM90-AD1505-D050-A22-Z05-H | ● | 50 | 5 | 22 | 40 | 15 | | | | 2508-M10x30 |
| AFM90-AD1505-D063-A22-Z06-H | ● | 63 | 6 | 22 | 40 | 15 | | | | 2510-M12x35 |
| AFM90-AD1505-D080-A27-Z07-H | ● | 80 | 7 | 27 | 50 | 15 | | | | 2514-M16x35 |
| AFM90-AD1505-D100-A32-Z08-H | ● | 100 | 8 | 32 | 50 | 15 | | | | - |
| AFM90-AD1505-D125-B40-Z09 | ● | 125 | 9 | 40 | 63 | 15 | | | | - |

ISCR Ucuna Uygundur. / Compatible with ISCR Insert.

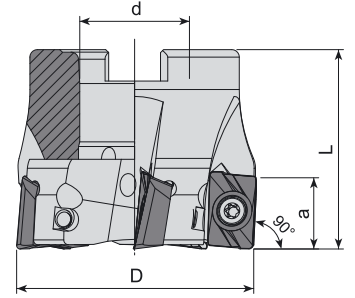

| Takım Kodu Ordering Code | Stok Stock | Takım Ölçüleri (mm) Dimension (mm) | | | | | Kesici Uç Insert | Yedek Parçaları Spare Parts | | |
|------------------------------|---------------|---------------------------------------|---|----|----|------|---------------------|--------------------------------|--------------------------|---------------------------------|
| | | D | Z | d | L | a | | Sıkma Vidası Screw | Tork Anahtar Torx Key | Montaj Vidası Mounting Screw |
| AFM90-AD1505D-D050-A22-Z05-H | ● | 50 | 5 | 22 | 40 | 14.3 | ADKT 150508 | 1515-M4x11 | 80-T15 | 2508-M10x30 |
| AFM90-AD1505D-D063-A27-Z06-H | ● | 63 | 6 | 27 | 50 | 14.3 | | | | 2510-M12x35 |
| AFM90-AD1505D-D080-A27-Z08-H | ● | 80 | 8 | 27 | 50 | 14.3 | | | | - |

R: Sağ/Right L: Sol/Left ● Stokta/In Stock ○ Stokta Yok/Non Stock Item
DJT Ucuna Uygundur. / Compatible with DJT Insert.

Sipariş Örneği/Ordering Example : 1 ad./pcs. AFM90-AD1505-D040-A16-Z04-H
Kesme Hesabı : S 211 / Cutting Calculation : P 211
Montaj Ölçüleri : S 209 / Mounting Reference : P 209

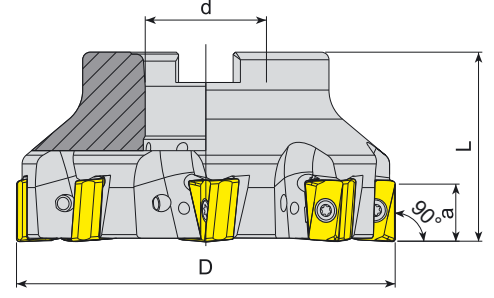

| Takım Kodu Ordering Code | Stok Stock | Takım Ölçüleri (mm) Dimension (mm) | | | | | Kesici Uç Insert | Yedek Parçaları Spare Parts | | |
|-----------------------------|---------------|---------------------------------------|---|----|----|----|---------------------|--------------------------------|--------------------------|---------------------------------|
| | | D | Z | d | L | a | | Sıkma Vidası Screw | Tork Anahtar Torx Key | Montaj Vidası Mounting Screw |
| AFM90-AN1607-D050-A22-Z04-H | ● | 50 | 4 | 22 | 40 | 15 | AN.X 1607.. | 1515-M4x11 | 80-T15 | 2508-M10x30 |
| AFM90-AN1607-D063-A22-Z06-H | ● | 63 | 6 | 22 | 40 | 15 | | | | 2510-M12x35 |
| AFM90-AN1607-D080-A27-Z07-H | ● | 80 | 7 | 27 | 50 | 15 | | | | 2514-M16x35 |
| AFM90-AN1607-D100-A32-Z08-H | ● | 100 | 8 | 32 | 50 | 15 | | | | |

TGTC Ucuna Uygunudur. / Compatible with TGTC Insert.

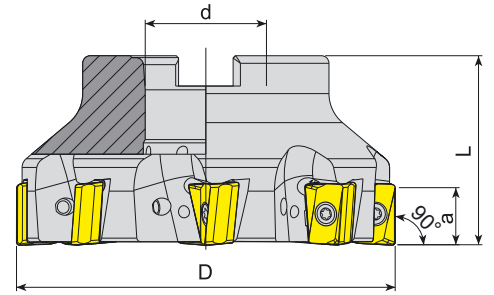

| Takım Kodu Ordering Code | Stok Stock | Takım Ölçüleri (mm) Dimension (mm) | | | | | Kesici Uç Insert | Yedek Parçaları Spare Parts | | |
|-----------------------------|---------------|---------------------------------------|---|----|----|------|---------------------|--------------------------------|--------------------------|---------------------------------|
| | | D | Z | d | L | a | | Sıkma Vidası Screw | Tork Anahtar Torx Key | Montaj Vidası Mounting Screw |
| AFM90-AN1506-D050-A22-Z04-H | ● | 50 | 4 | 22 | 40 | 14.5 | ANGX 150608 | 4015-M4x12 | 80-T15 | 2508-M10x30 |
| AFM90-AN1506-D063-A22-Z05-H | ● | 63 | 5 | 22 | 40 | 14.5 | | | | 2510-M12x35 |
| AFM90-AN1506-D080-A27-Z06-H | ● | 80 | 6 | 27 | 50 | 14.5 | | | | 2514-M16x35 |
| AFM90-AN1506-D100-A32-Z08-H | ● | 100 | 8 | 32 | 50 | 14.5 | | | | |

R: Sağ/Right L: Sol/Left ● Stokta/In Stock ○ Stokta Yok/Non Stock Item
ZCC Ucuna Uygunudur. / Compatible with ZCC Insert.

Sipariş Örneği/Ordering Example : 1 ad./pcs. AFM90-AN1607-D050-A22-Z04-H
Kesme Hesabı : S-144 / Cutting Calculation : P-144
Montaj Ölçüleri : S 209 / Mounting Reference : P 209

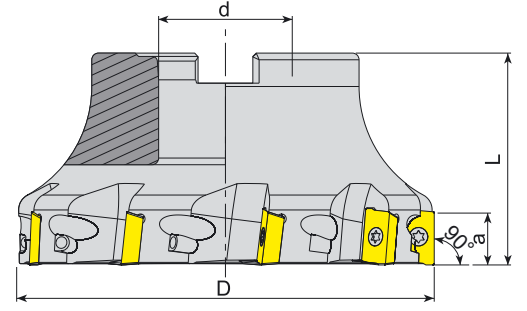

| Takım Kodu Ordering Code | Stok Stock | Takım Ölçüleri (mm) Dimension (mm) | | | | | Kesici Uç Insert | Yedek Parçaları Spare Parts | | |
|-----------------------------|---------------|---------------------------------------|----|----|----|----|---------------------|--------------------------------|--------------------------|---------------------------------|
| | | D | Z | d | L | a | | Sıkma Vidası Screw | Tork Anahtar Torx Key | Montaj Vidası Mounting Screw |
| AFM90-AP10-D040-A16-Z05-H | ● | 40 | 5 | 16 | 40 | 10 | AP. 1003.. | 3008-M2.5x6 | 80-T08 | 2506-M8x30 |
| AFM90-AP10-D050-A22-Z06-H | ● | 50 | 6 | 22 | 40 | 10 | | | | 2508-M10x30 |
| AFM90-AP10-D063-A22-Z07-H | ● | 63 | 7 | 22 | 40 | 10 | | | | 2510-M12x35 |
| AFM90-AP10-D080-A27-Z08-H | ● | 80 | 8 | 27 | 50 | 10 | | | | 2514-M16x35 |
| AFM90-AP10-D100-A32-Z09-H | ● | 100 | 9 | 32 | 50 | 10 | | | | 2506-M8x30 |
| AFM90-AP16-D040-A16-Z04-H | ● | 40 | 4 | 16 | 40 | 16 | AP. 1604.. | 1515-M4x11 | 80-T15 | 2508-M10x30 |
| AFM90-AP16-D050-A22-Z05-H | ● | 50 | 5 | 22 | 40 | 16 | | | | 2510-M12x35 |
| AFM90-AP16-D063-A22-Z06-H | ● | 63 | 6 | 22 | 40 | 16 | | | | 2514-M16x35 |
| AFM90-AP16-D080-A27-Z07-H | ● | 80 | 7 | 27 | 50 | 16 | | | | 2506-M8x30 |
| AFM90-AP16-D100-A32-Z08-H | ● | 100 | 8 | 32 | 50 | 16 | | | | 2508-M10x30 |
| AFM90-AP16-D125-B40-Z09 | ● | 125 | 9 | 40 | 63 | 16 | | | | 2510-M12x35 |
| AFM90-AP16-D160-C40-Z10 | ● | 160 | 10 | 40 | 63 | 16 | | | | 2514-M16x35 |
| AFM90-AP16-D200-C60-Z12 | ● | 200 | 12 | 60 | 63 | 16 | - | | | |

ISO Ucuna Uygundur. / Compatible with ISO Insert.

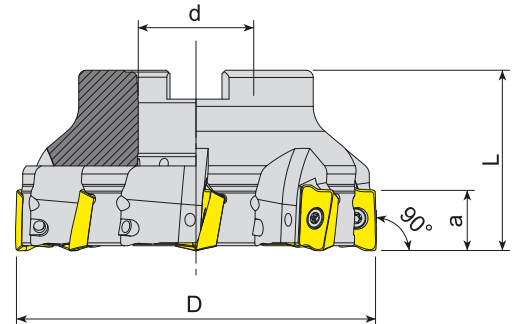

| Takım Kodu Ordering Code | Stok Stock | Takım Ölçüleri (mm) Dimension (mm) | | | | | Kesici Uç Insert | Yedek Parçaları Spare Parts | | |
|-----------------------------|---------------|---------------------------------------|---|----|----|----|---------------------|--------------------------------|--------------------------|---------------------------------|
| | | D | Z | d | L | a | | Sıkma Vidası Screw | Tork Anahtar Torx Key | Montaj Vidası Mounting Screw |
| AFM90-AP1705-D050-A22-Z05-H | ● | 50 | 5 | 22 | 40 | 16 | AP. 1705.. | 1515-M4x11 | 80-T15 | 2508-M10x30 |
| AFM90-AP1705-D063-A22-Z06-H | ● | 63 | 6 | 22 | 40 | 16 | | | | 2510-M12x35 |
| AFM90-AP1705-D080-A27-Z07-H | ● | 80 | 7 | 27 | 50 | 16 | | | | 2514-M16x35 |
| AFM90-AP1705-D100-A32-Z08-H | ● | 100 | 8 | 32 | 50 | 16 | | | | - |

R: Sağ/Right L: Sol/Left ● Stokta/In Stock ○ Stokta Yok/Non Stock Item
TGTC-LMN Ucuna Uygundur. / Compatible with TGTC-LMN Insert.

Sipariş Örneği/Ordering Example : 1 ad./pcs. AFM90-AP1705-D050-A22-Z05-H
Kesme Hesabı : S 211 / Cutting Calculation : P 211
Montaj Ölçüleri : S 209 / Mounting Reference : P 209

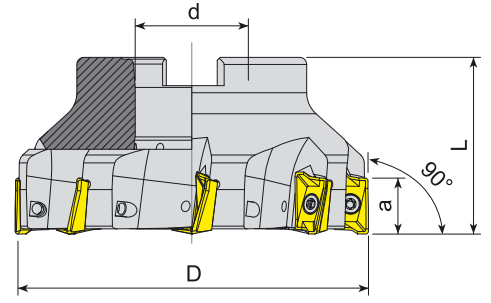

| Takım Kodu Ordering Code | Stok Stock | Takım Ölçüleri (mm) Dimension (mm) | | | | | Kesici Uç Insert | Yedek Parçaları Spare Parts | | |
|-----------------------------|---------------|---------------------------------------|---|----|----|----|---------------------|--------------------------------|--------------------------|---------------------------------|
| | | D | Z | d | L | a | | Sıkma Vidası Screw | Tork Anahtar Torx Key | Montaj Vidası Mounting Screw |
| AFM90-AX1705-D040-A16-Z04-H | ● | 40 | 4 | 16 | 40 | 14 | AX.T 1705.. | 1515-M4x11 | 80-T15 | 2506-M8x30 |
| AFM90-AX1705-D050-A22-Z05-H | ● | 50 | 5 | 22 | 40 | 14 | | | | 2508-M10x30 |
| AFM90-AX1705-D063-A22-Z06-H | ● | 63 | 6 | 22 | 40 | 14 | | | | 2510-M12x35 |
| AFM90-AX1705-D080-A27-Z07-H | ● | 80 | 7 | 27 | 50 | 14 | | | | 2514-M16x35 |
| AFM90-AX1705-D100-A32-Z08-H | ● | 100 | 8 | 32 | 50 | 14 | | | | |

SMTM Ucuna Uygunudur. / Compatiple with SMTM Insert.

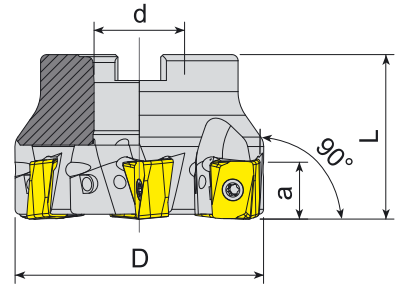

| Takım Kodu Ordering Code | Stok Stock | Takım Ölçüleri (mm) Dimension (mm) | | | | | Kesici Uç Insert | Yedek Parçaları Spare Parts | | |
|-----------------------------|---------------|---------------------------------------|---|----|----|----|---------------------|--------------------------------|--------------------------|---------------------------------|
| | | D | Z | d | L | a | | Sıkma Vidası Screw | Tork Anahtar Torx Key | Montaj Vidası Mounting Screw |
| AFM90-LN1307-D050-A22-Z04-H | ● | 50 | 4 | 22 | 40 | 13 | LNGX 1307.. | 1315-M4x11 | 80-T15 | 2508-M10x30 |
| AFM90-LN1307-D063-A22-Z06-H | ● | 63 | 6 | 22 | 40 | 13 | | | | 2510-M12x35 |
| AFM90-LN1307-D080-A27-Z07-H | ● | 80 | 7 | 27 | 50 | 13 | | | | 2514-M16x35 |
| AFM90-LN1307-D100-A32-Z08-H | ● | 100 | 8 | 32 | 50 | 13 | | | | |

R: Sağ/Right L: Sol/Left ● Stokta/In Stock ○ Stokta Yok/Non Stock Item
WLTR Ucuna Uygunudur. / Compatiple with WLTR Insert.

Sipariş Örneği/Ordering Example : 1 ad./pcs. AFM90-AX1705-D040-A16-Z04-H
Kesme Hesabı : S 211 / Cutting Calculation : P 211
Montaj Ölçüleri : S 209 / Mounting Reference : P 209

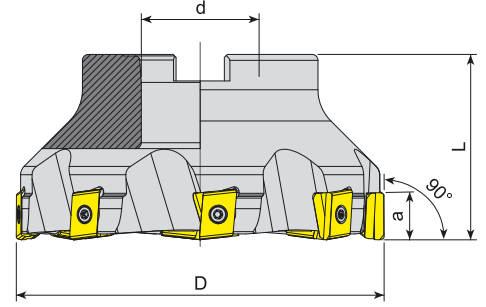

| Takım Kodu Ordering Code | Stok Stock | Takım Ölçüleri (mm) Dimension (mm) | | | | | Kesici Uç Insert | Yedek Parçaları Spare Parts | | | |
|-----------------------------|---------------|---------------------------------------|---|----|----|----|---------------------|--------------------------------|--------------------------|---------------------------------|-------------|
| | | D | Z | d | L | a | | Sıkma Vidası Screw | Tork Anahtar Torx Key | Montaj Vidası Mounting Screw | |
| AFM90-LN15Z-D050-A22-Z04 | ● | 50 | 4 | 22 | 40 | 15 | LNKT 1506.. | | | | |
| AFM90-LN15Z-D063-A22-Z05 | ● | 63 | 5 | 22 | 40 | 15 | | | | | 2508-M10x30 |
| AFM90-LN15Z-D080-A27-Z06 | ● | 80 | 6 | 27 | 50 | 15 | | | | | 2510-M12x35 |
| AFM90-LN15Z-D100-A32-Z07 | ● | 100 | 7 | 32 | 50 | 15 | | | | | 2514-M16x35 |
| AFM90-LN15Z-D125-B40-Z08 | ● | 125 | 8 | 40 | 63 | 15 | | | | | - |

ZCC Ucuna Uygundur. / Compatiple with ZCC Insert.

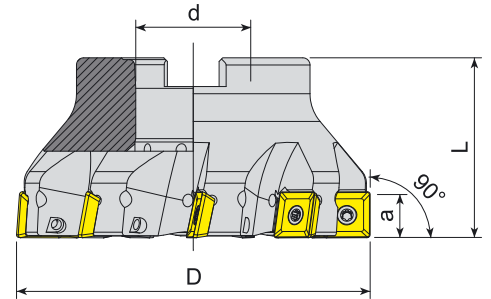

| Takım Kodu Ordering Code | Stok Stock | Takım Ölçüleri (mm) Dimension (mm) | | | | | Kesici Uç Insert | Yedek Parçaları Spare Parts | | | |
|------------------------------|---------------|---------------------------------------|----|----|----|------|---------------------|--------------------------------|--------------------------|---------------------------------|-------------|
| | | D | Z | d | L | a | | Sıkma Vidası Screw | Tork Anahtar Torx Key | Montaj Vidası Mounting Screw | |
| AFM90-R290.12-D050-A22-Z04-H | ● | 50 | 4 | 22 | 40 | 10.7 | R290-12T3.. | | | | |
| AFM90-R290.12-D063-A22-Z05-H | ● | 63 | 5 | 22 | 40 | 10.7 | | | | | 2508-M10x30 |
| AFM90-R290.12-D080-A27-Z07-H | ● | 80 | 7 | 27 | 50 | 10.7 | | | | | 2510-M12x35 |
| AFM90-R290.12-D100-A32-Z09-H | ● | 100 | 9 | 32 | 50 | 10.7 | | | | | 2514-M16x35 |
| AFM90-R290.12-D125-B40-Z11 | ● | 125 | 11 | 40 | 63 | 10.7 | | | | | - |

R: Sağ/Right L: Sol/Left ● Stokta/In Stock ○ Stokta Yok/Non Stock Item
SNDVK Ucuna Uygundur. / Compatiple with SNDVK Insert.

Sipariş Örneği/Ordering Example : 1 ad./pcs. AFM90-LN15Z-D050-A22-Z04
Kesme Hesabı : S 211 / Cutting Calculation : P 211
Montaj Ölçüleri : S 209 / Mounting Reference : P 209

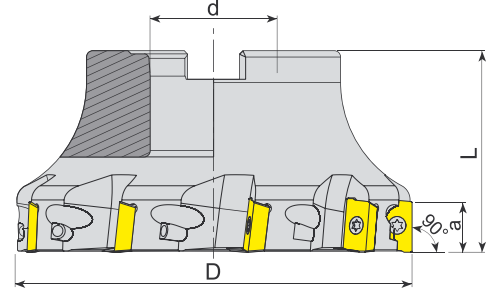

| Takım Kodu Ordering Code | Stok Stock | Takım Ölçüleri (mm) Dimension (mm) | | | | | Kesici Uç Insert | Yedek Parçaları Spare Parts | | |
|------------------------------|---------------|---------------------------------------|---|----|----|------|---------------------|--------------------------------|--------------------------|---------------------------------|
| | | D | Z | d | L | a | | Sıkma Vidası Screw | Tork Anahtar Torx Key | Montaj Vidası Mounting Screw |
| AFM90-R390.11-D040-A16-Z05-H | ● | 40 | 5 | 16 | 40 | 10 | R390-11T3.. | 3008-M2.5x6 | 80-T08 | 2506-M8x30 |
| AFM90-R390.11-D050-A22-Z06-H | ● | 50 | 6 | 22 | 40 | 10 | | | | 2508-M10x30 |
| AFM90-R390.11-D063-A22-Z07-H | ● | 63 | 7 | 22 | 40 | 10 | | | | 2510-M12x35 |
| AFM90-R390.11-D080-A27-Z09-H | ● | 80 | 9 | 27 | 50 | 10 | R390-1704.. | 4015-M3.5x11 | 80-T15 | 2506-M8x30 |
| AFM90-R390.17-D040-A16-Z04-H | ● | 40 | 4 | 16 | 40 | 15.4 | | | | 2508-M10x30 |
| AFM90-R390.17-D050-A22-Z05-H | ● | 50 | 5 | 22 | 40 | 15.4 | | | | 2510-M12x35 |
| AFM90-R390.17-D063-A22-Z06-H | ● | 63 | 6 | 22 | 40 | 15.4 | | | | 2514-M16x35 |
| AFM90-R390.17-D080-A27-Z07-H | ● | 80 | 7 | 27 | 50 | 15.4 | | | | - |
| AFM90-R390.17-D100-A32-Z08-H | ● | 100 | 8 | 32 | 50 | 15.4 | | | | - |
| AFM90-R390.17-D125-B40-Z09 | ● | 125 | 9 | 40 | 63 | 15.4 | R390-1806.. | 1515-M4x11 | 80-T15 | 2508-M10x30 |
| AFM90-R390.18-D050-A22-Z04-H | ● | 50 | 4 | 22 | 40 | 15.4 | | | | 2510-M12x35 |
| AFM90-R390.18-D063-A22-Z05-H | ● | 63 | 5 | 22 | 40 | 15.4 | | | | 2514-M16x35 |
| AFM90-R390.18-D080-A27-Z06-H | ● | 80 | 6 | 27 | 50 | 15.4 | | | | - |
| AFM90-R390.18-D100-A32-Z07-H | ● | 100 | 7 | 32 | 50 | 15.4 | | | | - |
| AFM90-R390.18-D125-B40-Z08 | ● | 125 | 8 | 40 | 63 | 15.4 | - | - | - | |

SNDVK Ucuna Uygundur. / Compatible with SNDVK Insert.

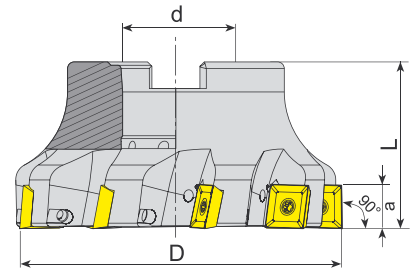

| Takım Kodu Ordering Code | Stok Stock | Takım Ölçüleri (mm) Dimension (mm) | | | | | Kesici Uç Insert | Yedek Parçaları Spare Parts | | |
|-----------------------------|---------------|---------------------------------------|---|----|----|----|---------------------|--------------------------------|--------------------------|---------------------------------|
| | | D | Z | d | L | a | | Sıkma Vidası Screw | Tork Anahtar Torx Key | Montaj Vidası Mounting Screw |
| AFM90-490R14-D050-A22-Z04-H | ● | 50 | 4 | 22 | 40 | 10 | 490R-1404.. | 4015-M3.5x11 | 80-T15 | 2508-M10x30 |
| AFM90-490R14-D063-A22-Z05-H | ● | 63 | 5 | 22 | 40 | 10 | | | | 2510-M12x35 |
| AFM90-490R14-D080-A27-Z07-H | ● | 80 | 7 | 27 | 50 | 10 | | | | - |

R: Sağ/Right L: Sol/Left ● Stokta/In Stock ○ Stokta Yok/Non Stock Item
SNDVK Ucuna Uygundur. / Compatible with SNDVK Insert.

Sipariş Örneği/Ordering Example : 1 ad./pcs. AFM90-R390.11-D040-A16-Z05-H
Kesme Hesabı : S 211 / Cutting Calculation : P 211
Montaj Ölçüleri : S 209 / Mounting Reference : P 209

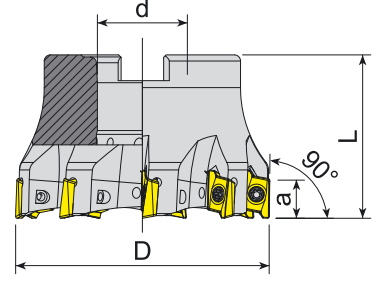

| Takım Kodu Ordering Code | Stok Stock | Takım Ölçüleri (mm) Dimension (mm) | | | | | Kesici Uç Insert | Yedek Parçaları Spare Parts | | |
|-----------------------------|---------------|---------------------------------------|---|----|----|----|---------------------|--------------------------------|--------------------------|---------------------------------|
| | | D | Z | d | L | a | | Sıkma Vidası Screw | Tork Anahtar Torx Key | Montaj Vidası Mounting Screw |
| AFM90-RT10-D040-A16-Z06-H | ● | 40 | 6 | 16 | 40 | 10 | RT 1003.. | 3008-M2.5x6 | 80-T08 | 2506-M8x30 |
| AFM90-RT10-D050-A22-Z07-H | ● | 50 | 7 | 22 | 40 | 10 | | | | 2508-M10x30 |
| AFM90-RT10-D063-A22-Z09-H | ● | 63 | 9 | 22 | 40 | 10 | | | | |

SFTY Ucuna Uygun. / Compatible with SFTY Insert.

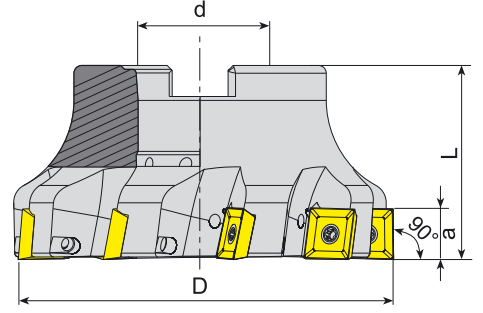

| Takım Kodu Ordering Code | Stok Stock | Takım Ölçüleri (mm) Dimension (mm) | | | | | Kesici Uç Insert | Yedek Parçaları Spare Parts | | |
|-----------------------------|---------------|---------------------------------------|----|----|----|----|---------------------|--------------------------------|--------------------------|---------------------------------|
| | | D | Z | d | L | a | | Sıkma Vidası Screw | Tork Anahtar Torx Key | Montaj Vidası Mounting Screw |
| AFM90-SD09M4-D040-A16-Z04-H | ● | 40 | 4 | 16 | 40 | 9 | SD.. 09M4.. | 4015-M3.5x11 | 80-T15 | 2406-M8x30 |
| AFM90-SD09M4-D050-A22-Z05-H | ● | 50 | 5 | 22 | 40 | 9 | | | | 2508-M10x30 |
| AFM90-SD09M4-D063-A22-Z06-H | ● | 63 | 6 | 22 | 40 | 9 | | | | |
| AFM90-SD1305-D050-A22-Z04-H | ● | 50 | 4 | 22 | 40 | 13 | SD.. 1305.. | 1020-M5x11 | 80-T20 | 2408-M10x30 |
| AFM90-SD1305-D063-A22-Z05-H | ● | 63 | 5 | 22 | 40 | 13 | | | | 2508-M10x30 |
| AFM90-SD1305-D080-A27-Z06-H | ● | 80 | 6 | 27 | 50 | 13 | | | | 2510-M12x35 |
| AFM90-SD1305-D100-A32-Z07-H | ● | 100 | 7 | 32 | 50 | 13 | | | | 2514-M16x35 |
| AFM90-SD1305-D125-B40-Z08 | ● | 125 | 8 | 40 | 63 | 13 | | | | |
| AFM90-SD1305-D160-C40-Z10 | ● | 160 | 10 | 40 | 63 | 13 | | | | |
| | | | | | | | | | | |
| | | | | | | | | | | |

R: Sağ/Right L: Sol/Left ● Stokta/In Stock ○ Stokta Yok/Non Stock Item
KRLY Ucuna Uygun. / Compatible with KRLY Insert.

Sipariş Örneği/Ordering Example : 1 ad./pcs. AFM90-RT10-D040-A16-Z06-H
Kesme Hesabı : S 211 / Cutting Calculation : P 211
Montaj Ölçüleri : S 209 / Mounting Reference : P 209

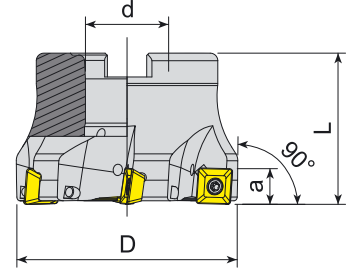

| Takım Kodu Ordering Code | Stok Stock | Takım Ölçüleri (mm) Dimension (mm) | | | | | Kesici Uç Insert | Yedek Parçaları Spare Parts | | |
|-----------------------------|---------------|---------------------------------------|---|----|----|-----|---------------------|--------------------------------|--------------------------|---------------------------------|
| | | D | Z | d | L | a | | Sıkma Vidası Screw | Tork Anahtar Torx Key | Montaj Vidası Mounting Screw |
| AFM90-SE09-D040-A16-Z04-H | ● | 40 | 4 | 16 | 40 | 6.7 | SEET 09T3.. | 1008-M3x8 | 80-T08 | 2506-M8x30 |
| AFM90-SE09-D050-A22-Z05-H | ● | 50 | 5 | 22 | 40 | 6.7 | | | | 2508-M10x30 |
| AFM90-SE09-D063-A22-Z06-H | ● | 63 | 6 | 22 | 40 | 6.7 | | | | |

ZCC Ucuna Uygunudur. / Compatible with ZCC Insert.

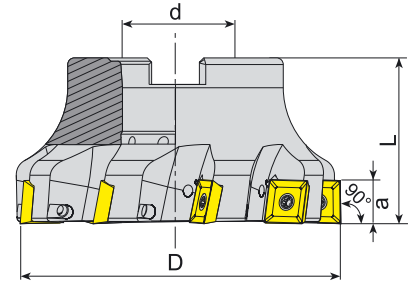

| Takım Kodu Ordering Code | Stok Stock | Takım Ölçüleri (mm) Dimension (mm) | | | | | Kesici Uç Insert | Yedek Parçaları Spare Parts | | |
|-----------------------------|---------------|---------------------------------------|----|----|----|----|---------------------|--------------------------------|--------------------------|---------------------------------|
| | | D | Z | d | L | a | | Sıkma Vidası Screw | Tork Anahtar Torx Key | Montaj Vidası Mounting Screw |
| AFM90-SE12-D050-A22-Z04-H | ● | 50 | 4 | 22 | 40 | 12 | SEET 1203.. | 4015-M3.5x11 | 80-T15 | 2508-M10x30 |
| AFM90-SE12-D063-A22-Z05-H | ● | 63 | 5 | 22 | 40 | 12 | | | | 2510-M12x35 |
| AFM90-SE12-D080-A27-Z07-H | ● | 80 | 7 | 27 | 50 | 12 | | | | 2514-M16x35 |
| AFM90-SE12-D100-A32-Z09-H | ● | 100 | 9 | 32 | 50 | 12 | | | | - |
| AFM90-SE12-D125-B40-Z11 | ● | 125 | 11 | 40 | 63 | 12 | | | | |

R: Sağ/Right L: Sol/Left ● Stokta/In Stock ○ Stokta Yok/Non Stock Item
ZCC Ucuna Uygunudur. / Compatible with ZCC Insert.

Sipariş Örneği/Ordering Example : 1 ad./pcs. AFM90-SE09-D040-A16-Z04-H
Kesme Hesabı : S 211 / Cutting Calculation : P 211
Montaj Ölçüleri : S 209 / Mounting Reference : P 209

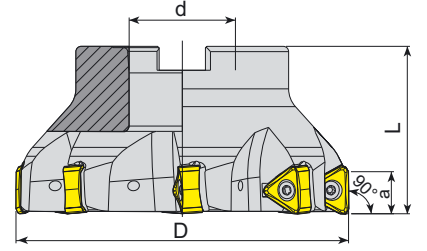

| Takım Kodu Ordering Code | Stok Stock | Takım Ölçüleri (mm) Dimension (mm) | | | | | Kesici Uç Insert | Yedek Parçaları Spare Parts | | |
|-----------------------------|---------------|---------------------------------------|---|----|----|----|---------------------|--------------------------------|--------------------------|---------------------------------|
| | | D | Z | d | L | a | | Sıkma Vidası Screw | Tork Anahtar Torx Key | Montaj Vidası Mounting Screw |
| AFM90-TN2207-D063-A22-Z04-H | ● | 63 | 4 | 22 | 40 | 15 | TN.X 2207.. | | | 2508-M10x30 |
| AFM90-TN2207-D080-A27-Z05-H | ● | 80 | 5 | 27 | 50 | 15 | | | | 2510-M12x35 |
| AFM90-TN2207-D100-B32-Z06 | ● | 100 | 6 | 32 | 50 | 15 | | | | - |
| AFM90-TN2207-D125-B40-Z08 | ● | 125 | 8 | 40 | 63 | 15 | | | | - |

TGTC Ucuna Uygunudur. / Compatible with TGTC Insert.

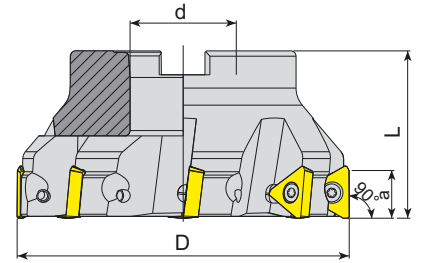

| Takım Kodu Ordering Code | Stok Stock | Takım Ölçüleri (mm) Dimension (mm) | | | | | Kesici Uç Insert | Yedek Parçaları Spare Parts | | |
|-----------------------------|---------------|---------------------------------------|----|----|----|----|---------------------|--------------------------------|--------------------------|---------------------------------|
| | | D | Z | d | L | a | | Sıkma Vidası Screw | Tork Anahtar Torx Key | Montaj Vidası Mounting Screw |
| AFM90-TP2205-D063-A22-Z04 | ● | 63 | 4 | 22 | 40 | 18 | TPKT 2205.. | | | 2508-M10x30 |
| AFM90-TP2205-D080-A27-Z06 | ● | 80 | 6 | 27 | 50 | 18 | | | | 2510-M12x35 |
| AFM90-TP2205-D100-A32-Z07 | ● | 100 | 7 | 32 | 50 | 18 | | | | 2514-M16x35 |
| AFM90-TP2205-D125-B40-Z08 | ● | 125 | 8 | 40 | 63 | 18 | | | | - |
| AFM90-TP2205-D160-C40-Z09 | ● | 160 | 9 | 40 | 63 | 18 | | | | - |
| AFM90-TP2205-D200-C60-Z12 | ● | 200 | 12 | 60 | 63 | 18 | | | | - |

R: Sağ/Right L: Sol/Left ● Stokta/In Stock ○ Stokta Yok/Non Stock Item
TGTC Ucuna Uygunudur. / Compatible with TGTC Insert.

Sipariş Örneği/Ordering Example : 1 ad./pcs. AFM90-TN2207-D063-A22-Z04-H
Kesme Hesabı : S 211 / Cutting Calculation : P 211
Montaj Ölçüleri : S 209 / Mounting Reference : P 209

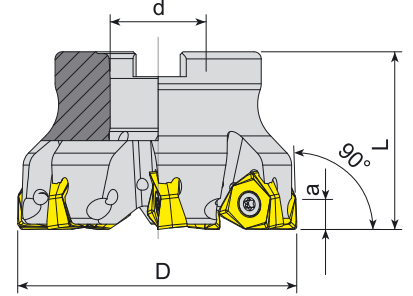

| Takım Kodu Ordering Code | Stok Stock | Takım Ölçüleri (mm) Dimension (mm) | | | | | Kesici Uç Insert | Yedek Parçaları Spare Parts | | | | |
|-----------------------------|---------------|---------------------------------------|---|----|----|---|---------------------|--------------------------------|--------------------------|---------------------------------|--------|-------------|
| | | D | Z | d | L | a | | Sıkma Vidası Screw | Tork Anahtar Torx Key | Montaj Vidası Mounting Screw | | |
| AFM90-WN0806-D050-A16-Z04-H | ● | 50 | 4 | 16 | 40 | 8 | WNNX 080608 | | | 2506-M8x30 | | |
| AFM90-WN0806-D063-A22-Z05-H | ● | 63 | 5 | 22 | 40 | 8 | | | | 1615-M5x14 | 80-T15 | 2508-M10x30 |
| AFM90-WN0806-D080-A27-Z07-H | ● | 80 | 7 | 27 | 50 | 8 | | | | | | 2510-M12x35 |

KYCR-JD Ucuna Uygundur. / Compatible with KYCR-JD Insert.

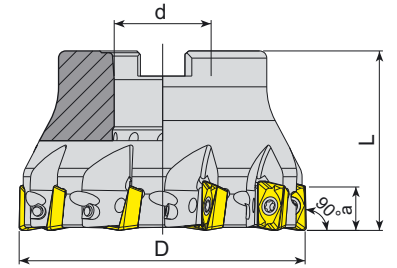

| Takım Kodu Ordering Code | Stok Stock | Takım Ölçüleri (mm) Dimension (mm) | | | | | Kesici Uç Insert | Yedek Parçaları Spare Parts | | | | |
|-----------------------------|---------------|---------------------------------------|----|----|----|----|---------------------|--------------------------------|--------------------------|---------------------------------|--------|-------------|
| | | D | Z | d | L | a | | Sıkma Vidası Screw | Tork Anahtar Torx Key | Montaj Vidası Mounting Screw | | |
| AFM90-X012-D040-A16-Z05-H | ● | 40 | 5 | 16 | 40 | 11 | XO.. 1204.. | | | 2506-M8x30 | | |
| AFM90-X012-D050-A22-Z07-H | ● | 50 | 7 | 22 | 40 | 11 | | | | 1510-M3.5x9 | 80-T10 | 2508-M10x30 |
| AFM90-X012-D063-A22-Z08-H | ● | 63 | 8 | 22 | 40 | 11 | | | | | | 2510-M12x35 |
| AFM90-X012-D080-A27-Z10-H | ● | 80 | 10 | 27 | 50 | 11 | | | | | | |

R: Sağ/Right L: Sol/Left ● Stokta/In Stock ○ Stokta Yok/Non Stock Item
SC Ucuna Uygundur. / Compatible with SC Insert.

Sipariş Örneği/Ordering Example : 1 ad./pcs. AFM90-WN0806-D050-A16-Z04-H
Kesme Hesabı : S 211 / Cutting Calculation : P 211
Montaj Ölçüleri : S 209 / Mounting Reference : P 209

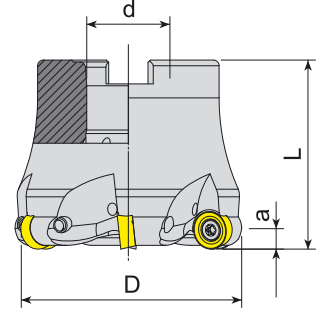

| Takım Kodu Ordering Code | Stok Stock | Takım Ölçüleri (mm) Dimension (mm) | | | | | Kesici Uç Insert | Yedek Parçaları Spare Parts | | |
|-----------------------------|---------------|---------------------------------------|---|----|----|---|---------------------|--------------------------------|--------------------------|---------------------------------|
| | | D | Z | d | L | a | | Sıkma Vidası Screw | Tork Anahtar Torx Key | Montaj Vidası Mounting Screw |
| AFMR-RC10T3-D040-A16-Z04-H | ● | 40 | 4 | 16 | 40 | 5 | RC.. 10T3.. | 1515-M4x11 | 80-T15 | 2406-M8x30 |
| AFMR-RC10T3-D050-A22-Z05-H | ● | 50 | 5 | 22 | 50 | 5 | | | | 2508-M10x30 |
| AFMR-RC10T3-D063-A22-Z06-H | ● | 63 | 6 | 22 | 50 | 5 | | | | |

ZCC Ucuna Uygundur. / Compatiple with ZCC Insert.

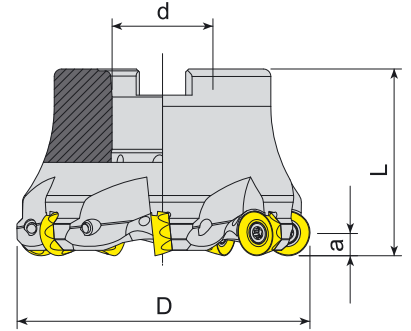

| Takım Kodu Ordering Code | Stok Stock | Takım Ölçüleri (mm) Dimension (mm) | | | | | Kesici Uç Insert | Yedek Parçaları Spare Parts | | |
|-----------------------------|---------------|---------------------------------------|---|----|----|---|---------------------|--------------------------------|--------------------------|---------------------------------|
| | | D | Z | d | L | a | | Sıkma Vidası Screw | Tork Anahtar Torx Key | Montaj Vidası Mounting Screw |
| AFMR-RC1204-D050-A22-Z05-H | ● | 50 | 5 | 22 | 50 | 6 | RC.. 1204.. | 4015-M3.5x11 | 80-T15 | 2508-M10x30 |
| AFMR-RC1204-D063-A22-Z06-H | ● | 63 | 6 | 22 | 50 | 6 | | | | 2510-M12x35 |
| AFMR-RC1204-D080-A27-Z07-H | ● | 80 | 7 | 27 | 50 | 6 | | | | |

R: Sağ/Right L: Sol/Left ● Stokta/In Stock ○ Stokta Yok/Non Stock Item
SNDVK Ucuna Uygundur. / Compatiple with SNDVK Insert.

Sipariş Örneği/Ordering Example : 1 ad./pcs. AFMR-RC10T3-D040-A16-Z04-H
Kesme Hesabı : S 211 / Cutting Calculation : P 211
Montaj Ölçüleri : S 209 / Mounting Reference : P 209

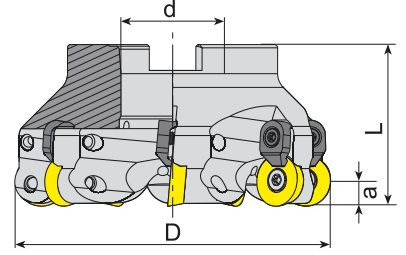

| Takım Kodu Ordering Code | Stok Stock | Takım Ölçüleri (mm) Dimension (mm) | | | | | Kesici Uç Insert | Yedek Parçaları Spare Parts | | | | | | | | | |
|-----------------------------|---------------|---------------------------------------|---|----|----|-----|---------------------|--------------------------------|------------------------------|-----------------------------|--------------------------|---------------------------------|--------------|--------|--------------|--------|-------------|
| | | D | Z | d | L | a | | Sıkma Vidası Screw | Baskı Parçası Wedge Clamp | Baskı Vidası Clamp Screw | Tork Anahtar Torx Key | Montaj Vidası Mounting Screw | | | | | |
| AFMR-RD0702-D050-A22-Z06-H | ● | 50 | 6 | 22 | 40 | 3.5 | RD.. 0702.. | 3008-M2.5x6 | - | - | 80-T08 | 2407-M10x30 | | | | | |
| AFMR-RD0803-D050-A22-Z05-H | ● | 50 | 5 | 22 | 40 | 4 | RD.. 0803.. | 1008-M3x8 | - | - | 80-T08 | 2407-M10x30 | | | | | |
| AFMRC-RD1003-D040-A16-Z04-H | ● | 40 | 4 | 16 | 40 | 5 | RD.. 1003.. | | | | | 2406-M8x30 | | | | | |
| AFMRC-RD1003-D050-A22-Z05-H | ● | 50 | 5 | 22 | 40 | 5 | | | | | | 2508-M10x30 | | | | | |
| AFMRC-RD1003-D063-A22-Z06-H | ● | 63 | 6 | 22 | 40 | 5 | | | | | | 2510-M12x35 | | | | | |
| AFMRC-RD1003-D080-A27-Z07-H | ● | 80 | 7 | 27 | 50 | 5 | | | | | | 2514-M16x35 | | | | | |
| AFMRC-RD1003-D100-A32-Z08-H | ● | 100 | 8 | 32 | 50 | 5 | | | | | | 2508-M10x30 | | | | | |
| AFMRC-RD10T3-D050-A22-Z05-H | ● | 50 | 5 | 22 | 40 | 5 | RD.. 10T3.. | | | | | 2406-M8x30 | | | | | |
| AFMRC-RD10T3-D063-A22-Z06-H | ● | 63 | 6 | 22 | 40 | 5 | | | | | | 2508-M10x30 | | | | | |
| AFMRC-RD12T3-D040-A16-Z04-H | ● | 40 | 4 | 16 | 40 | 6 | | | | | | RD.. 12T3.. | 4015-M3.5x11 | ACK-15 | 1015-M3.5x11 | 80-T15 | 2508-M10x30 |
| AFMRC-RD12T3-D050-A22-Z05-H | ● | 50 | 5 | 22 | 40 | 6 | | | | | | | | | | | 2510-M12x35 |
| AFMRC-RD12T3-D052-A22-Z05-H | ● | 52 | 5 | 22 | 40 | 6 | | | | | | | | | | | 2514-M16x35 |
| AFMRC-RD12T3-D063-A22-Z06-H | ● | 63 | 6 | 22 | 40 | 6 | - | | | | | | | | | | |
| AFMRC-RD12T3-D080-A27-Z07-H | ● | 80 | 7 | 27 | 50 | 6 | 2406-M8x30 | | | | | | | | | | |
| AFMRC-RD12T3-D100-A32-Z08-H | ● | 100 | 8 | 32 | 50 | 6 | RD.. 1204.. | | | | | 2508-M10x30 | | | | | |
| AFMRC-RD1204-D040-A16-Z04-H | ● | 40 | 4 | 16 | 40 | 6 | | | | | | 2510-M12x35 | | | | | |
| AFMRC-RD1204-D050-A22-Z05-H | ● | 50 | 5 | 22 | 40 | 6 | | | | | | 2514-M16x35 | | | | | |
| AFMRC-RD1204-D052-A22-Z05-H | ● | 52 | 5 | 22 | 40 | 6 | | | | | | - | | | | | |
| AFMRC-RD1204-D063-A22-Z06-H | ● | 63 | 6 | 22 | 40 | 6 | | | | | | 2408-M10x30 | | | | | |
| AFMRC-RD1204-D080-A27-Z07-H | ● | 80 | 7 | 27 | 50 | 6 | RD.. 1604.. | 1515-M4.5x11 | ACK-05 | 1515-M4x11 | | 2508-M10x30 | | | | | |
| AFMRC-RD1204-D100-A32-Z07-H | ● | 100 | 7 | 32 | 50 | 6 | | | | | | 2510-M12x35 | | | | | |
| AFMRC-RD1204-D100-A32-Z08-H | ● | 100 | 8 | 32 | 50 | 6 | | | | | | 2514-M16x35 | | | | | |
| AFMRC-RD1604-D050-A22-Z04-H | ● | 50 | 4 | 22 | 40 | 8 | | | | | | RD.. 1604.. | 1515-M4.5x11 | ACK-05 | 1515-M4x11 | | 2408-M10x30 |
| AFMRC-RD1604-D052-A22-Z04-H | ● | 52 | 4 | 22 | 40 | 8 | | | | | | | | | | | 2508-M10x30 |
| AFMRC-RD1604-D063-A22-Z05-H | ● | 63 | 5 | 22 | 40 | 8 | 2510-M12x35 | | | | | | | | | | |
| AFMRC-RD1604-D080-A27-Z06-H | ● | 80 | 6 | 27 | 50 | 8 | 2514-M16x35 | | | | | | | | | | |
| AFMRC-RD1604-D100-A32-Z07-H | ● | 100 | 7 | 32 | 50 | 8 | - | | | | | | | | | | |
| AFMRC-RD1604-D125-B40-Z07 | ● | 125 | 7 | 40 | 63 | 8 | | | | | | | | | | | |

R: Sağ/Right L: Sol/Left ● Stokta/In Stock ○ Stokta Yok/Non Stock Item
ISO Ucuna Uygundur. / Compatible with ISO Insert.

Sipariş Örneği/Ordering Example : 1 ad./pcs. AFMR-RD0702-D050-A22-Z06-H
Kesme Hesabı : S 211 / Cutting Calculation : P 211
Montaj Ölçüleri : S 209 / Mounting Reference : P 209

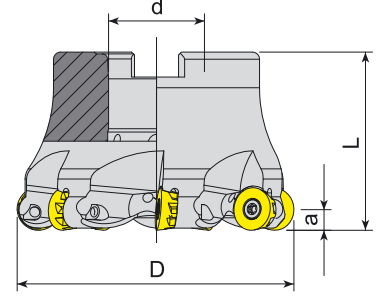

| Takım Kodu Ordering Code | Stok Stock | Takım Ölçüleri (mm) Dimension (mm) | | | | | Kesici Uç Insert | Yedek Parçaları Spare Parts | | |
|-----------------------------|---------------|---------------------------------------|---|----|----|---|---------------------|--------------------------------|--------------------------|---------------------------------|
| | | D | Z | d | L | a | | Sıkma Vidası Screw | Tork Anahtar Torx Key | Montaj Vidası Mounting Screw |
| AFMR-RP10T3-D063-A22-Z06-H | ● | 63 | 6 | 22 | 40 | 5 | RPNX 10T3.. | 4010-M3x8 | 80-T10 | 2508-M10x30 |
| AFMR-RP10T3-D080-A27-Z07-H | ● | 80 | 7 | 27 | 50 | 5 | | | | 2510-M12x35 |
| AFMR-RP1204-D040-A16-Z04-H | ● | 40 | 4 | 16 | 40 | 6 | RPNX 1204.. | 4015-M3.5x11 | 80-T15 | 2406-M8x30 |
| AFMR-RP1204-D080-A27-Z07-H | ● | 80 | 7 | 27 | 50 | 6 | | | | 2510-M12x35 |

CRTZT Ucuna Uygunur. / Compatiple with CRTZT Insert.

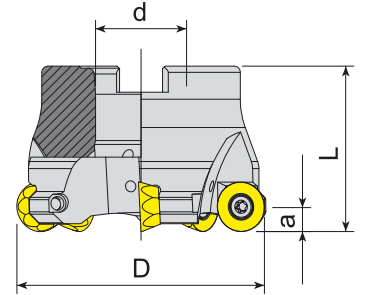

| Takım Kodu Ordering Code | Stok Stock | Takım Ölçüleri (mm) Dimension (mm) | | | | | Kesici Uç Insert | Yedek Parçaları Spare Parts | | |
|-----------------------------|---------------|---------------------------------------|---|----|----|---|---------------------|--------------------------------|--------------------------|---------------------------------|
| | | D | Z | d | L | a | | Sıkma Vidası Screw | Tork Anahtar Torx Key | Montaj Vidası Mounting Screw |
| AFMR-QP10T3-D040-A16-Z04-H | ● | 40 | 4 | 16 | 40 | 5 | QP. 10T3.. | 4015-M3.5x11 | 80-T15 | 2506-M8x30 |
| AFMR-QP10T3-D050-A22-Z05-H | ● | 50 | 5 | 22 | 40 | 5 | | | | 2407-M10x30 |
| AFMR-QP10T3-D063-A22-Z06-H | ● | 63 | 6 | 22 | 40 | 5 | QP. 1204.. | 1515-M4x11 | 80-T15 | 2407-M10x30 |
| AFMR-QP1204-D063-A22-Z05-H | ● | 63 | 5 | 22 | 40 | 6 | | | | 2407-M10x30 |

R: Sağ/Right L: Sol/Left ● Stokta/In Stock ○ Stokta Yok/Non Stock Item
SMTM Ucuna Uygunur. / Compatiple with SMTM Insert.

Sipariş Örneği/Ordering Example : 1 ad./pcs. AFMR-RP10T3-D063-A22-Z06-H
Kesme Hesabı : S 211 / Cutting Calculation : P 211
Montaj Ölçüleri : S 209 / Mounting Reference : P 209

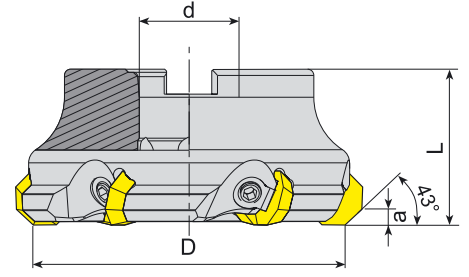

| Takım Kodu Ordering Code | Stok Stock | Takım Ölçüleri (mm) Dimension (mm) | | | | | Kesici Uç Insert | Yedek Parçaları Spare Parts | | | |
|-----------------------------|---------------|---------------------------------------|---|----|----|---|---------------------|--------------------------------|-----------------------------|----------------------|---------------------------------|
| | | D | Z | d | L | a | | Baskı Pabucu Wedge Clamp | Baskı Vidası Clamp Screw | Anahtar Allen Key | Montaj Vidası Mounting Screw |
| AFM43C-0F07-D063-A22-Z04 | ● | 63 | 4 | 22 | 40 | 5 | OF.. 0704.. | ACK-11 | AKV-15-M8x1x20 | AAL-05-4 | 2508-M10x30 |
| AFM43C-0F07-D080-A27-Z05 | ● | 80 | 5 | 27 | 50 | 5 | | | | | 2510-M12x35 |
| AFM43C-0F07-D100-A32-Z06 | ● | 100 | 6 | 32 | 50 | 5 | | | | | 2514-M16x35 |
| AFM43C-0F07-D125-B40-Z08 | ● | 125 | 8 | 40 | 63 | 5 | | | | | - |
| AFM43C-0F07-D160-C40-Z09 | ● | 160 | 9 | 40 | 63 | 5 | | | | | - |

ISO Ucuna Uygundur. / Compatiple with ISO Insert.

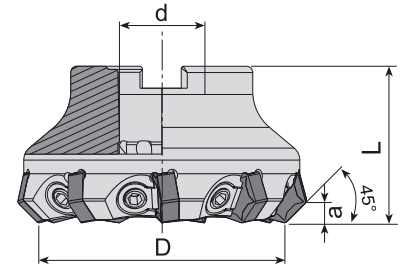

| Takım Kodu Ordering Code | Stok Stock | Takım Ölçüleri (mm) Dimension (mm) | | | | | Kesici Uç Insert | Yedek Parçaları Spare Parts | | | |
|-----------------------------|---------------|---------------------------------------|----|----|----|-----|---------------------|--------------------------------|-----------------------------|----------------------|---------------------------------|
| | | D | Z | d | L | a | | Baskı Pabucu Wedge Clamp | Baskı Vidası Clamp Screw | Anahtar Allen Key | Montaj Vidası Mounting Screw |
| AFM45C-HN0905-D063-A22-Z07 | ● | 63 | 7 | 22 | 40 | 4.5 | HN.. 0905.. | ACK-11 | AKV-15-M8x1x20 | AAL-05-4 | 2508-M10x30 |
| AFM45C-HN0905-D080-A27-Z09 | ● | 80 | 9 | 27 | 50 | 4.5 | | | | | 2510-M12x35 |
| AFM45C-HN0905-D100-A32-Z11 | ● | 100 | 11 | 32 | 50 | 4.5 | | | | | 2514-M16x35 |
| AFM45C-HN0905-D125-B40-Z13 | ● | 125 | 13 | 40 | 63 | 4.5 | | | | | - |
| AFM45C-HN0905-D160-C40-Z15 | ● | 160 | 15 | 40 | 63 | 4.5 | | | | | - |

R: Sağ/Right L: Sol/Left ● Stokta/In Stock ○ Stokta Yok/Non Stock Item
WDA-KNMTL Ucuna Uygundur. / Compatiple with WDA-KNMTL Insert.

Sipariş Örneği/Ordering Example : 1 ad./pcs. AFM45C-HN0905-D063-A22-Z07
Kesme Hesabı : S 211 / Cutting Calculation : P 211
Montaj Ölçüleri : S 209 / Mounting Reference : P 209

75°

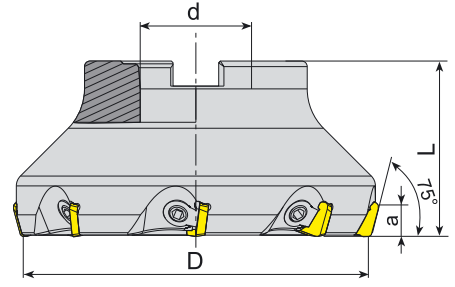

| Takım Kodu Ordering Code | Stok Stock | Takım Ölçüleri (mm) Dimension (mm) | | | | | Kesici Uç Insert | Yedek Parçaları Spare Parts | | | |
|-----------------------------|---------------|---------------------------------------|----|----|----|---|---------------------|--------------------------------|-----------------------------|----------------------|---------------------------------|
| | | D | Z | d | L | a | | Baskı Pabucu Wedge Clamp | Baskı Vidası Clamp Screw | Anahtar Allen Key | Montaj Vidası Mounting Screw |
| AFM75C-SP12-D050-A22-Z04 | ● | 50 | 4 | 22 | 42 | 8 | SPKN 1203.. | ACK-10 | AKV-13-M8x1x16 | AAL-05-4 | 2508-M10x30 |
| AFM75C-SP12-D063-A22-Z05 | ● | 63 | 5 | 22 | 40 | 8 | | | | | 2510-M12x35 |
| AFM75C-SP12-D080-A27-Z06 | ● | 80 | 6 | 27 | 50 | 8 | | | | | 2514-M16x35 |
| AFM75C-SP12-D100-A32-Z07 | ● | 100 | 7 | 32 | 50 | 8 | | | | | - |
| AFM75C-SP12-D125-B40-Z08 | ● | 125 | 8 | 40 | 63 | 8 | | | | | - |
| AFM75C-SP12-D160-C40-Z09 | ● | 160 | 9 | 40 | 63 | 8 | | | | | - |
| AFM75C-SP12-D200-C60-Z12 | ● | 200 | 12 | 60 | 63 | 8 | | | | | - |

ISO Ucuna Uygundur. / Compatible with ISO Insert.

90°

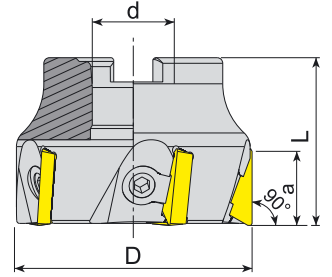

| Takım Kodu Ordering Code | Stok Stock | Takım Ölçüleri (mm) Dimension (mm) | | | | | Kesici Uç Insert | Yedek Parçaları Spare Parts | | | |
|-----------------------------|---------------|---------------------------------------|----|----|----|----|---------------------|--------------------------------|----------------------------------|----------------------|---------------------------------|
| | | D | Z | d | L | a | | Baskı Pabucu Wedge Clamp | Baskı Vidası Clamp Screw | Anahtar Allen Key | Montaj Vidası Mounting Screw |
| AFM90C-TP16-D050-A22-Z04 | ● | 50 | 4 | 22 | 40 | 12 | TP.. 1603.. | ACK-10 | AKV-22-M8x1x14 AKV-13-M8x1x16 | AAL-05-4 | 2408-M10x30 |
| AFM90C-TP16-D063-A22-Z06 | ● | 63 | 6 | 22 | 45 | 12 | | | | | 2508-M10x30 |
| AFM90C-TP16-D080-A27-Z07 | ● | 80 | 7 | 27 | 50 | 12 | | | | | 2510-M12x35 |
| AFM90C-TP16-D100-A32-Z08 | ● | 100 | 8 | 32 | 50 | 12 | | | | | 2514-M16x35 |
| AFM90C-TP22-D063-A22-Z05 | ● | 63 | 5 | 22 | 45 | 18 | TP.. 2204.. | ACK-11 | AKV-14-M8x1x18 | AAL-05-4 | 2508-M10x30 |
| AFM90C-TP22-D080-A27-Z06 | ● | 80 | 6 | 27 | 50 | 18 | | | | | 2510-M12x35 |
| AFM90C-TP22-D100-A32-Z07 | ● | 100 | 7 | 32 | 50 | 18 | | | | | 2514-M16x35 |
| AFM90C-TP22-D125-B40-Z08 | ● | 125 | 8 | 40 | 63 | 18 | | | | | - |
| AFM90C-TP22-D160-C40-Z09 | ● | 160 | 9 | 40 | 63 | 18 | | | | | - |
| AFM90C-TP22-D200-C60-Z12 | ● | 200 | 12 | 60 | 63 | 18 | | | | | - |
| AFM90C-TP22-D250-C60-Z15 | ● | 250 | 15 | 60 | 63 | 18 | | | | | - |
| AFM90C-TP22-D315-D60-Z18 | ● | 315 | 18 | 60 | 63 | 18 | | | | | - |

R: Sağ/Right L: Sol/Left ● Stokta/In Stock ○ Stokta Yok/Non Stock Item
ISO Ucuna Uygundur. / Compatible with ISO Insert.

Sipariş Örneği/Ordering Example : 1 ad./pcs. AFM75C-SP12-D050-A22-Z04

Kesme Hesabı : S 211 / Cutting Calculation : P 211

Montaj Ölçüleri : S 209 / Mounting Reference : P 209

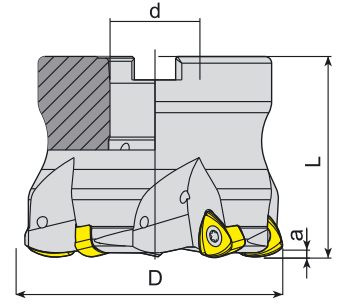

| Takım Kodu Ordering Code | Stok Stock | Takım Ölçüleri (mm) Dimension (mm) | | | | | Kesici Uç Insert | Yedek Parçaları Spare Parts | | |
|-----------------------------|---------------|---------------------------------------|---|----|----|---|---------------------|--------------------------------|--------------------------|---------------------------------|
| | | D | Z | d | L | a | | Sıkma Vidası Screw | Tork Anahtar Torx Key | Montaj Vidası Mounting Screw |
| AHFM-BL1205-D050-A22-Z03-H | ● | 50 | 3 | 22 | 40 | 2 | BLMP 1205.. | 1515-M4x11 | 80-T15 | 2508-M10x30 |
| AHFM-BL1205-D063-A22-Z04-H | ● | 63 | 4 | 22 | 40 | 2 | | | | |
| AHFM-BL1205-D080-A27-Z05-H | ● | 80 | 5 | 27 | 50 | 2 | | | | |

TGTC Ucuna Uygundur. / Compatiple with TGTC Insert.

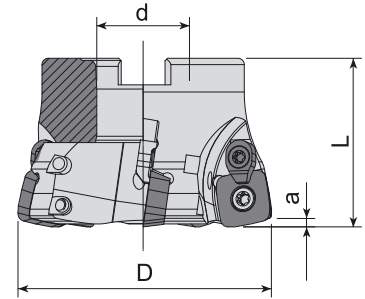



| Takım Kodu Ordering Code | Stok Stock | Takım Ölçüleri (mm) Dimension (mm) | | | | | Kesici Uç Insert | Yedek Parçaları Spare Parts | | | | |
|-----------------------------|---------------|---------------------------------------|---|----|----|-----|---------------------|--------------------------------|------------------------------|-----------------------------|--------------------------|---------------------------------|
| | | D | Z | d | L | a | | Sıkma Vidası Screw | Baskı Parçası Wedge Clamp | Baskı Vidası Clamp Screw | Tork Anahtar Torx Key | Montaj Vidası Mounting Screw |
| AHFMC-SD1204-D050-A22-Z04-H | ● | 50 | 4 | 22 | 40 | 1.8 | SD.. 1204.. | 1515-M4x11 | ACK-15 | 1015-M3.5x11 | 80-T15 | 2508-M10x30 |
| AHFMC-SD1204-D063-A22-Z05-H | ● | 63 | 5 | 22 | 40 | 1.8 | | | | | | |

R: Sağ/Right L: Sol/Left ● Stokta/In Stock ○ Stokta Yok/Non Stock Item
ZCC Ucuna Uygundur. / Compatiple with ZCC Insert.

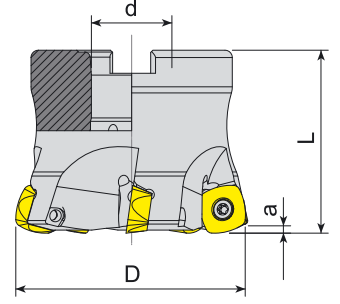

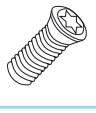

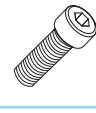
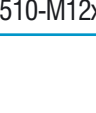
Sipariş Örneği/Ordering Example : 1 ad./pcs. AHFM-BL1205-D050-A22-Z03-H
Kesme Hesabı : S 211 / Cutting Calculation : P 211
Montaj Ölçüleri : S 209 / Mounting Reference : P 209

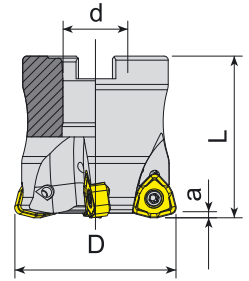

| Takım Kodu Ordering Code | Stok Stock | Takım Ölçüleri (mm) Dimension (mm) | | | | | Kesici Uç Insert | Yedek Parçaları Spare Parts | | |
|-----------------------------|---------------|---------------------------------------|---|----|----|---|--|---|---|--|
| | | D | Z | d | L | a | | Sıkma Vidası Screw | Tork Anahtar Torx Key | Montaj Vidası Mounting Screw |
| AHFM-SD1205-D052-A22-Z04-H | ● | 52 | 4 | 22 | 50 | 2 |  |  |  |  |
| AHFM-SD1205-D052-A22-Z05-H | ● | 52 | 5 | 22 | 50 | 2 | | | | |
| AHFM-SD1205-D066-A22-Z05-H | ● | 66 | 5 | 22 | 50 | 2 | | | | |
| AHFM-SD1205-D066-A22-Z06-H | ● | 66 | 6 | 22 | 50 | 2 | | | | |
| AHFM-SD1205-D080-A27-Z06-H | ● | 80 | 6 | 27 | 70 | 2 | | | |  |

HTCH Ucuna Uygundur. / Compatible with HTCH Insert.

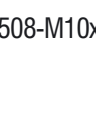

| Takım Kodu Ordering Code | Stok Stock | Takım Ölçüleri (mm) Dimension (mm) | | | | | Kesici Uç Insert | Yedek Parçaları Spare Parts | | |
|-----------------------------|---------------|---------------------------------------|---|----|----|-----|--|---|---|---|
| | | D | Z | d | L | a | | Sıkma Vidası Screw | Tork Anahtar Torx Key | Montaj Vidası Mounting Screw |
| AHFM-WN09T3-D040-A16-Z04-H | ● | 40 | 4 | 16 | 40 | 1.5 |  |  |  |  |
| AHFML-WN09T3-D040-A16-Z04-H | ● | 40 | 4 | 16 | 40 | 1.5 | | | | |
| AHFM-WN09T3-D050-A22-Z05-H | ● | 50 | 5 | 22 | 40 | 1.5 | | | | |
| AHFML-WN09T3-D050-A22-Z05-H | ● | 50 | 5 | 22 | 40 | 1.5 | | | | |
| AHFM-WN09T3-D063-A22-Z06-H | ● | 63 | 6 | 22 | 40 | 1.5 | | | |  |

R: Sağ/Right L: Sol/Left ● Stokta/In Stock ○ Stokta Yok/Non Stock Item
KRLY Ucuna Uygundur. / Compatible with KRLY Insert.

Sipariş Örneği/Ordering Example : 1 ad./pcs. AHFM-SD1205-D052-A22-Z04-H
Kesme Hesabı : S 211 / Cutting Calculation : P 211
Montaj Ölçüleri : S 209 / Mounting Reference : P 209

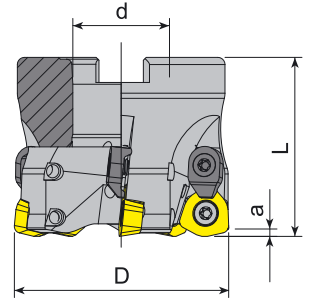

| Takım Kodu Ordering Code | Stok Stock | Takım Ölçüleri (mm) Dimension (mm) | | | | | Kesici Uç Insert | Yedek Parçaları Spare Parts | | | | |
|-----------------------------|---------------|---------------------------------------|---|----|----|---|---------------------|--------------------------------|------------------------------|-----------------------------|--------------------------|---------------------------------|
| | | D | Z | d | L | a | | Sıkma Vidası Screw | Baskı Parçası Wedge Clamp | Baskı Vidası Clamp Screw | Tork Anahtar Torx Key | Montaj Vidası Mounting Screw |
| AHFMC-WD0804-D040-A16-Z04-H | ● | 40 | 4 | 16 | 40 | - | WDMT 0804.. | 4010-M3x8 | ACK-15 | 4010-M3x8 | 80-T10 | 2506-M8x30 |
| AHFMC-WD1205-D050-A22-Z04-H | ● | 50 | 4 | 22 | 50 | - | WDMT 1205.. | 1415-M4x11 | ACK-05 | 1515-M4x11 | 80-T15 | 2508-M10x30 |
| AHFMC-WD1205-D063-A22-Z05-H | ● | 63 | 5 | 22 | 50 | - | | | | | | 2510-M12x35 |
| AHFMC-WD1205-D080-A27-Z06-H | ● | 80 | 6 | 27 | 63 | - | | | | | | |

SMTM Ucuna Uygundur. / Compatible with SMTM Insert.

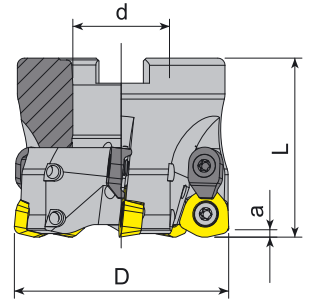

| Takım Kodu Ordering Code | Stok Stock | Takım Ölçüleri (mm) Dimension (mm) | | | | | Kesici Uç Insert | Yedek Parçaları Spare Parts | | | | |
|------------------------------|---------------|---------------------------------------|---|----|----|-----|---------------------|--------------------------------|------------------------------|-----------------------------|--------------------------|---------------------------------|
| | | D | Z | d | L | a | | Sıkma Vidası Screw | Baskı Parçası Wedge Clamp | Baskı Vidası Clamp Screw | Tork Anahtar Torx Key | Montaj Vidası Mounting Screw |
| AHFMC-WD06T3D-D042-A16-Z04-H | ● | 42 | 4 | 16 | 45 | 1.5 | WDMT 06T3.. | 3015-M3.5x9 | ACK-15 | 1015-M3.5x11 | 80-T15 | 2506-M8x30 |
| AHFMC-WD06T3D-D050-A22-Z05-H | ● | 50 | 5 | 22 | 50 | 1.5 | | | | | | 2508-M10x30 |
| AHFMC-WD06T3D-D052-A22-Z05-H | ● | 52 | 5 | 22 | 50 | 1.5 | | | | | | |
| AHFMC-WD0805D-D052-A22-Z04-H | ● | 52 | 4 | 22 | 50 | 2 | WDMT 0805.. | 4020-M4.5x12 | ACK-05 | 4020-M4.5x12 | 80-T20 | 2510-M12x35 |
| AHFMC-WD0805D-D063-A27-Z05-H | ● | 63 | 5 | 27 | 50 | 2 | | | | | | |

R: Sağ/Right L: Sol/Left ● Stokta/In Stock ○ Stokta Yok/Non Stock Item
DJT Ucuna Uygundur. / Compatible with DJT Insert.

Sipariş Örneği/Ordering Example : 1 ad./pcs. AHFMC-WD0804-D040-A16-Z04-H
Kesme Hesabı : S 211 / Cutting Calculation : P 211
Montaj Ölçüleri : S 209 / Mounting Reference : P 209

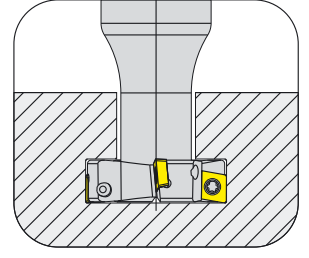
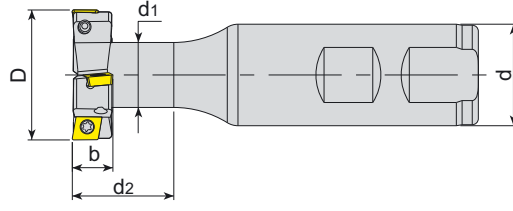

Takım Kodu
Ordering Code

| Takım Kodu Ordering Code | Stok Stock | Takım Ölçüleri (mm) Dimension (mm) | | | | | | | | Yedek Parçaları Spare Parts | | |
|---------------------------------|---------------|---------------------------------------|---------------------|----|----|----|-----|----------------|----------------|--------------------------------|-----------------------|--------------------------|
| | | Z | | D | b | d | L | d ₁ | d ₂ | Kesici Uç Insert | Sıkma Vidası Screw | Tork Anahtar Torx Key |
| | | Toplam Total | Etkili Effective | | | | | | | | | |
| ATSM90-CC06-D17X8-W16-L85-Z02 | ● | 2 | 1 | 17 | 8 | 16 | 85 | 10 | 16 | CC.. 0602.. | 3008-M2.5x6 | 80-T08 |
| ATSM90-CC06-D32X8-W25-L100-Z04 | ● | 4 | 2 | 32 | 8 | 25 | 100 | 16 | 23 | | | |
| ATSM90-CC06-D63X8-W32-L125-Z08 | ● | 8 | 4 | 63 | 8 | 32 | 125 | 31.5 | 30 | | | |
| ATSM90-CC06-D18X9-W16-L90-Z02 | ● | 2 | 1 | 18 | 9 | 16 | 90 | 10 | 16 | | | |
| ATSM90-CC06-D20X9-W16-L85-Z04 | ● | 4 | 2 | 20 | 9 | 16 | 85 | 10 | 16 | | | |
| ATSM90-CC06-D23X10-W20-L90-Z04 | ● | 4 | 2 | 23 | 10 | 20 | 90 | 12 | 25 | | | |
| ATSM90-CC06-D32X10-W25-L100-Z04 | ● | 4 | 2 | 32 | 10 | 25 | 100 | 16 | 25 | | | |
| ATSM90-CC06-D45X10-W32-L120-Z06 | ● | 6 | 3 | 45 | 10 | 32 | 120 | 20 | 25 | | | |
| ATSM90-CC06-D25X11-W25-L100-Z04 | ● | 4 | 2 | 25 | 11 | 25 | 100 | 13 | 20 | | | |
| ATSM90-CC09-D30X12-W25-L100-Z04 | ● | 4 | 2 | 30 | 12 | 25 | 100 | 16 | 25 | | | |
| ATSM90-CC09-D32X12-W25-L100-Z02 | ● | 2 | 1 | 32 | 12 | 25 | 100 | 16 | 25 | | | |
| ATSM90-CC09-D32X12-W25-L100-Z04 | ● | 4 | 2 | 32 | 12 | 25 | 100 | 16 | 25 | | | |
| ATSM90-CC09-D32X14-W25-L100-Z04 | ● | 4 | 2 | 32 | 14 | 25 | 100 | 16 | 25 | | | |
| ATSM90-CC09-D37X16-W32-L120-Z04 | ● | 4 | 2 | 37 | 16 | 32 | 120 | 17 | 30 | | | |
| ATSM90-CC09-D42X17-W32-L120-Z04 | ● | 4 | 2 | 42 | 17 | 32 | 120 | 19 | 30 | | | |
| ATSM90-CC09-D40X17-W32-L120-Z04 | ● | 4 | 2 | 40 | 17 | 32 | 120 | 19 | 30 | | | |
| ATSM90-CC12-D47X20-W32-L120-Z04 | ● | 4 | 2 | 47 | 20 | 32 | 120 | 25 | 45 | CC.. 1204.. | 1020-M5x11 | 80-T20 |
| ATSM90-CC12-D52X21-W32-L120-Z04 | ● | 4 | 2 | 52 | 21 | 32 | 120 | 25 | 45 | | | |
| ATSM90-CC12-D50X22-W32-L120-Z04 | ● | 4 | 2 | 50 | 22 | 32 | 120 | 25 | 45 | | | |
| ATSM90-CC12-D55X22-W32-L120-Z04 | ● | 4 | 2 | 55 | 22 | 32 | 120 | 25 | 45 | | | |

R: Sağ/Right L: Sol/Left ● Stokta/In Stock ○ Stokta Yok/Non Stock Item

Sipariş Örneği/Ordering Example : 1 ad./pcs. ATSM90-CC06-D17X8-W16-L85-Z02
Kesme Hesabı : S 211 / Cutting Calculation : P 211



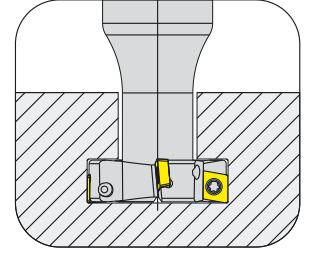
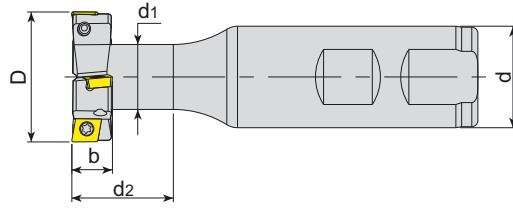

| Takım Kodu Ordering Code | Stok Stock | Takım Ölçüleri (mm) Dimension (mm) | | | | | | | Yedek Parçaları Spare Parts | | | |
|---------------------------------------|---------------|---------------------------------------|---------------------|----|----|----|-----|----------------|--------------------------------|---------------------|-----------------------|--------------------------|
| | | Z | | D | b | d | L | d ₁ | d ₂ | Kesici Uç Insert | Sıkma Vidası Screw | Tork Anahtar Torx Key |
| | | Toplam Total | Etkili Effective | | | | | | | | | |
| ATSM90-SPGT0904-D37X16-W32-L120-Z04-H | ● | 4 | 2 | 37 | 16 | 32 | 120 | 21 | 40 | SPGT 090408 | 4015-M3.5x9 | 80-T15 |
| ATSM90-SPGT0904-D42X17-W32-L120-Z04-H | ● | 4 | 2 | 42 | 17 | 32 | 120 | 21 | 40 | | | |
| ATSM90-SPGT1104-D47X20-W32-L120-Z04-H | ● | 4 | 2 | 47 | 20 | 32 | 120 | 24 | 45 | SPGT 110408 | 1515-M4x11 | 80-T07 |
| ATSM90-SP.06-D80X7-W32-L120-Z10 | ● | 10 | 5 | 80 | 7 | 32 | 120 | 32 | 30 | SPMG 060204 | 3007-M2.2x5 | |

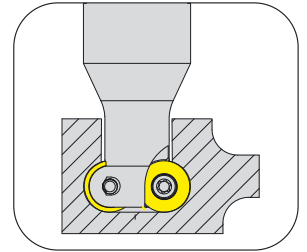
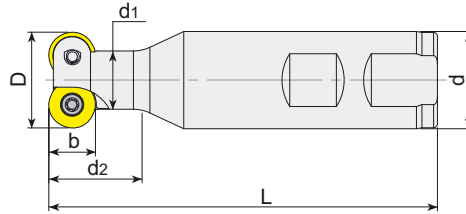

| Takım Kodu Ordering Code | Stok Stock | Takım Ölçüleri (mm) Dimension (mm) | | | | | | | Yedek Parçaları Spare Parts | | |
|-------------------------------|---------------|---------------------------------------|----|----|----|-----|----------------|----------------|--------------------------------|-----------------------|--------------------------|
| | | Z | D | b | d | L | d ₁ | d ₂ | Kesici Uç Insert | Sıkma Vidası Screw | Tork Anahtar Torx Key |
| | | ATSMR-RD0702-D17-W16-L90-Z02 | ● | 2 | 17 | 7 | 16 | 90 | | | |
| ATSMR-RD0702-D25-W16-L90-Z03 | ● | 3 | 25 | 7 | 16 | 90 | 15 | 12 | | | |
| ATSMR-RD0702-D35-W25-L100-Z05 | ● | 5 | 35 | 7 | 25 | 100 | 20 | 20 | RD.. 1003 | 4015-M3.5x9 | 80-T15 |
| ATSMR-RD1003-D21-W25-L100-Z02 | ● | 2 | 21 | 10 | 25 | 100 | 12 | 20 | | | |
| ATSMR-RD12T3-D25-W25-L100-Z02 | ● | 2 | 25 | 12 | 25 | 100 | 15 | 24 | RD.. 12T3 | 1515-M4.5x11 | 80-T15 |
| ATSMR-RD1604-D34-W32-L110-Z02 | ● | 2 | 34 | 16 | 32 | 110 | 20 | 30 | RD.. 1604 | | |

R: Sağ/Right L: Sol/Left ● Stokta/In Stock ○ Stokta Yok/Non Stock Item

Sipariş Örneği/Ordering Example : 1 ad./pcs. ATSM90-SPGT0904-D37X16-W32-L120-Z04-H
Kesme Hesabı : S 211 / Cutting Calculation : P 211

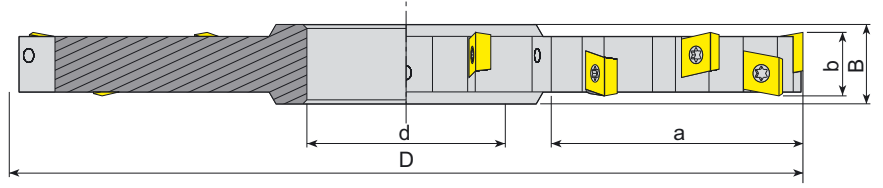

Takım Kodu
Ordering Code

Stok
Stock

Takım Ölçüleri (mm)
Dimension (mm)

Kesici Uç
Insert

Yedek Parçaları
Spare Parts

Sıkma Vidası
Screw

Tork Anahtar
Torx Key

| | Z | | D | b | a | d | B | | | | |
|---------------------------|-----------------|---------------------|---|-----|----|----|----|----|--|--------------|--------|
| | Toplam Total | Etkili Effective | | | | | | | | | |
| ASDM-SPM05-D80x6-d27-Z10 | ● | 10 | 5 | 80 | 6 | 17 | 27 | 10 | SPMT 050203 KRLY-JD UCUNA UYGUNDUR. FOR KRLY-JD INSERT. | 3006-M2x4 | 80-T06 |
| ASDM-SPM05-D100x6-d32-Z12 | ● | 12 | 6 | 100 | 6 | 25 | 32 | 10 | | | |
| ASDM-SPM05-D125x6-d40-Z14 | ● | 14 | 7 | 125 | 6 | 35 | 40 | 10 | | | |
| ASDM-SPM05-D160x6-d40-Z18 | ● | 18 | 9 | 160 | 6 | 52 | 40 | 10 | SPMT 060204 KRLY-JD UCUNA UYGUNDUR. FOR KRLY-JD INSERT. | 3007-M2.2x5 | 80-T07 |
| ASDM-SPM06-D80x7-d27-Z10 | ● | 10 | 5 | 80 | 7 | 17 | 27 | 11 | | | |
| ASDM-SPM06-D100x7-d32-Z12 | ● | 12 | 6 | 100 | 7 | 25 | 32 | 11 | | | |
| ASDM-SPM06-D125x7-d40-Z14 | ● | 14 | 7 | 125 | 7 | 35 | 40 | 11 | SPMT 060204 KRLY-JD UCUNA UYGUNDUR. FOR KRLY-JD INSERT. | 3007-M2.2x5 | 80-T07 |
| ASDM-SPM06-D160x7-d40-Z16 | ● | 16 | 8 | 160 | 7 | 52 | 40 | 11 | | | |
| ASDM-SPM06-D200x7-d40-Z18 | ● | 18 | 9 | 200 | 7 | 70 | 40 | 11 | | | |
| ASDM-CC06-D80x8-d27-Z10 | ● | 10 | 5 | 80 | 8 | 17 | 27 | 12 | CC.. 0602.. ISO UCUNA UYGUNDUR. FOR ISO INSERT. | 3008-M2.5x6 | 80-T08 |
| ASDM-CC06-D100x8-d32-Z12 | ● | 12 | 6 | 100 | 8 | 25 | 32 | 12 | | | |
| ASDM-CC06-D125x8-d40-Z14 | ● | 14 | 7 | 125 | 8 | 35 | 40 | 12 | | | |
| ASDM-CC06-D160x8-d40-Z16 | ● | 16 | 8 | 160 | 8 | 52 | 40 | 12 | | | |
| ASDM-CC06-D200x8-d40-Z18 | ● | 18 | 9 | 200 | 8 | 70 | 40 | 12 | | | |
| ASDM-CC06-D80x10-d27-Z10 | ● | 10 | 5 | 80 | 10 | 17 | 27 | 14 | | | |
| ASDM-CC06-D100x10-d32-Z12 | ● | 12 | 6 | 100 | 10 | 25 | 32 | 14 | | | |
| ASDM-CC06-D125x10-d40-Z14 | ● | 14 | 7 | 125 | 10 | 35 | 40 | 14 | | | |
| ASDM-CC06-D160x10-d40-Z16 | ● | 16 | 8 | 160 | 10 | 52 | 40 | 14 | | | |
| ASDM-CC06-D200x10-d40-Z18 | ● | 18 | 9 | 200 | 10 | 70 | 40 | 14 | | | |
| ASDM-CC09-D80x12-d27-Z08 | ● | 8 | 4 | 80 | 12 | 17 | 27 | 16 | CC.. 09T3.. ISO UCUNA UYGUNDUR. FOR ISO INSERT. | 4015-M3.5x11 | 80-T15 |
| ASDM-CC09-D100x12-d32-Z10 | ● | 10 | 5 | 100 | 12 | 25 | 32 | 16 | | | |
| ASDM-CC09-D125x12-d40-Z12 | ● | 12 | 6 | 125 | 12 | 35 | 40 | 16 | | | |
| ASDM-CC09-D160x12-d40-Z14 | ● | 14 | 7 | 160 | 12 | 52 | 40 | 16 | | | |
| ASDM-CC09-D200x12-d40-Z16 | ● | 16 | 8 | 200 | 12 | 70 | 40 | 16 | | | |
| ASDM-CC09-D80x14-d27-Z08 | ● | 8 | 4 | 80 | 14 | 17 | 27 | 18 | | | |
| ASDM-CC09-D100x14-d32-Z10 | ● | 10 | 5 | 100 | 14 | 25 | 32 | 18 | | | |
| ASDM-CC09-D125x14-d40-Z12 | ● | 12 | 6 | 125 | 14 | 35 | 40 | 18 | | | |
| ASDM-CC09-D160x14-d40-Z14 | ● | 14 | 7 | 160 | 14 | 52 | 40 | 18 | | | |
| ASDM-CC09-D200x14-d40-Z16 | ● | 16 | 8 | 200 | 14 | 70 | 40 | 18 | | | |
| ASDM-CC12-D80x16-d27-Z06 | ● | 6 | 3 | 80 | 16 | 17 | 27 | 20 | CC.. 1204.. ISO UCUNA UYGUNDUR. FOR ISO INSERT. | 1020-M5x11 | 80-T20 |
| ASDM-CC12-D100x16-d32-Z08 | ● | 8 | 4 | 100 | 16 | 25 | 32 | 20 | | | |
| ASDM-CC12-D125x16-d40-Z10 | ● | 10 | 5 | 125 | 16 | 35 | 40 | 20 | | | |
| ASDM-CC12-D160x16-d40-Z12 | ● | 12 | 6 | 160 | 16 | 52 | 40 | 20 | | | |
| ASDM-CC12-D200x16-d40-Z14 | ● | 14 | 7 | 200 | 16 | 70 | 40 | 20 | | | |
| ASDM-CC12-D80x18-d27-Z06 | ● | 6 | 3 | 80 | 18 | 17 | 27 | 22 | | | |
| ASDM-CC12-D100x18-d32-Z08 | ● | 8 | 4 | 100 | 18 | 25 | 32 | 22 | | | |
| ASDM-CC12-D125x18-d40-Z10 | ● | 10 | 5 | 125 | 18 | 35 | 40 | 22 | | | |
| ASDM-CC12-D160x18-d40-Z12 | ● | 12 | 6 | 160 | 18 | 52 | 40 | 22 | | | |
| ASDM-CC12-D200x18-d40-Z14 | ● | 14 | 7 | 200 | 18 | 70 | 40 | 22 | | | |
| ASDM-CC12-D250x18-d40-Z16 | ● | 16 | 8 | 250 | 18 | 90 | 40 | 22 | | | |
| ASDM-CC12-D80x20-d27-Z06 | ● | 6 | 3 | 80 | 20 | 17 | 27 | 24 | | | |
| ASDM-CC12-D100x20-d32-Z08 | ● | 8 | 4 | 100 | 20 | 25 | 32 | 24 | | | |
| ASDM-CC12-D125x20-d40-Z10 | ● | 10 | 5 | 125 | 20 | 35 | 40 | 24 | | | |
| ASDM-CC12-D160x20-d40-Z12 | ● | 12 | 6 | 160 | 20 | 52 | 40 | 24 | | | |
| ASDM-CC12-D200x20-d40-Z14 | ● | 14 | 7 | 200 | 20 | 70 | 40 | 24 | | | |
| ASDM-CC12-D250x20-d40-Z16 | ● | 16 | 8 | 250 | 20 | 90 | 40 | 24 | | | |

R: Sağ/Right L: Sol/Left ● Stokta/In Stock ○ Stokta Yok/Non Stock Item

Sipariş Örneği/Ordering Example : 1 ad./pcs. ASDM-SPM05-D80x6-d27-Z10
Kesme Hesabı : S 211 / Cutting Calculation : P 211



A TIP
A TYPE

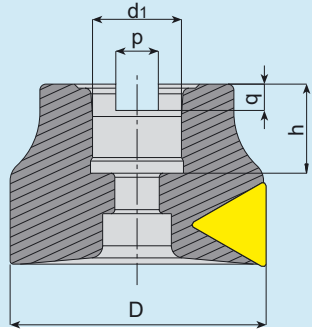

| D | d1 | d2 | p | q | h |
|-----|----|----|------|-----|----|
| 40 | 16 | - | 8.4 | 5.6 | 20 |
| 50 | 22 | - | 10.4 | 6.3 | 22 |
| 63 | 22 | - | 10.4 | 6.3 | 22 |
| 80 | 27 | - | 12.4 | 7 | 25 |
| 100 | 32 | - | 14.4 | 8 | 26 |

B TIP
B TYPE

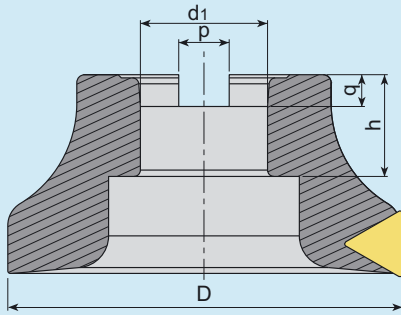

| D | d1 | d2 | p | q | h |
|-----|----|----|------|---|----|
| 125 | 40 | - | 16.4 | 9 | 32 |

C TIP
C TYPE

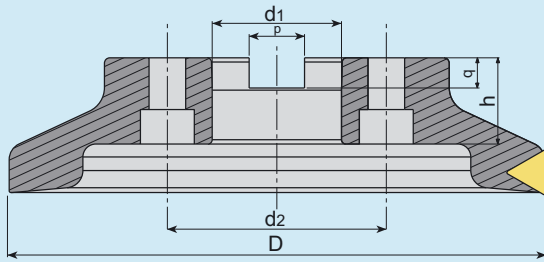

| D | d1 | d2 | p | q | h |
|-----|----|-------|------|----|----|
| 160 | 40 | 66.7 | 16.4 | 9 | 32 |
| 200 | 60 | 101.6 | 25.7 | 14 | 40 |
| 250 | 60 | 101.6 | 25.7 | 14 | 40 |

D TIP
D TYPE

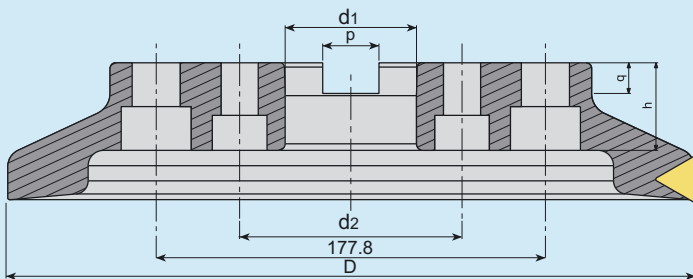

| D | d1 | d2 | p | q | h |
|-----|----|-------|------|----|----|
| 315 | 60 | 101.6 | 25.7 | 14 | 40 |

TAKMA UÇLU MATKAP (U-DRILL) KULLANMA KILAVUZU

Matkabınızı CNC torna tezgahına bağlamadan önce taretin merkezden kaçık olup olmadığını kontrol etmeniz gerekir. Şayet taretinizde kaçıklık varsa, takma uçlu matkabınızı kesinlikle kullanmayınız. Taretin düzeltilmesi için yapılması gereken işlemler ;

1. Taretin tutucusuna kullanacağınız takma uçlu matkabın çapında ve boyunda üzeri hassas olan silindirik bir parça bağlanır ve tezgahın X değeri sıfıra getirilir.
2. Tezgahın aynasına mıknatıslı komprotör saati yerleştirilir. Saatin uç kısmı tarete bağlanmış olduğumuz parçanın üstüne temas ettirilir.
3. Aynanın üzerine bağlanmış olduğumuz mıknatıslı komprotör ayna ile beraber 360 derece döndürülerek saatteki değişim oranına göre taretin sıfırlanması sağlanır.

TAKMA UÇLU MATKABINIZI CNC TORNANIZDA DAHA VERİMLİ KULLANMANIZ İÇİN GEREKLİ OLAN KESME HIZLARI ve DEVİRLERİ :

| Grup No. | Malzemenin Cinsi | Malzemenin Öz. | Kesme Hızı Vc (mm/dk) |
|----------|--------------------------------|-----------------------|-----------------------|
| 1 | Çok Yumuşak İş Çelikleri | C1010, Otomat vb. | 220 |
| 2 | İmalat Çelik ve Döküm Malz. | C1030 - 106 vb. | 200 |
| 3 | Takım ve İmalat Çeşitleri | CK-45, 4140, 7131 vb. | 170 |
| 4 | Sıcak İş ve Paslanmaz Çelikler | İmpaks vb. | 150 |

Devir hesabı yapabilmek için önce malzemeyi seçiniz. Seçtiğiniz malzemenin kesme hızını (Vc) 1000 ile çarpıp 3.14'e bölmeliyiz. Çıkan değeri matkap çapına bölmeliyiz. **ÖRNEK** : Malzememiz takım ve imalat çeliği (3. grup), matkap çapı 25 mm kesme hızı 170 ise $170 \times 1000 = 170000 / 3.14 = 54140$, $54140 / 25 = 2166$ devir çıkar (Tezgahın İş Mili Devri). Tezgahın ilerlemesi kullanacağınız uç ile de alakalı olup 0.05 ile 0.10 arasında değişim gösterir. Kullanıcı kesici ucun kesişine göre bunu ayarlar.

İŞLEME MERKEZLERİ İÇİN İLERLEME HESABI :

Yukarıdaki hesaplamalarla bulmuş olduğunuz 2166 iş mili devrini, kesici uç ilerlemesi (mm/devir) 0.05 ile 0.10 arasındaki ilerleme seçenekleri ile çarpılır. **ÖRNEK 1** : $2166 \times 0.05 = 108$ **ÖRNEK 2** : $2166 \times 0.10 = 217$ çıkan sonuçlar 108 ve 217 işleme merkezleri için ilerleme mm/dakika hesabıdır.

USER'S GUIDE FOR AKKO U-DRILLS

Before connecting your U-Drill to CNC lathe, you have to check if the turret is eccentric from the center or not. If there is any eccentricity in your turret, never use your U-Drill;

Processes that should be done to fix the turret :

1. A cylindrical part whose surface is precision and whose length and diameter is the same with the U-Drill that you will use, should be mounted to the holder of turret and X value of the lathe should be brought to zero (0).
2. Comparator should be mounted to chuck. The end of the comparator should be contacted (touched) to the surface of the part that we mounted on the turret.
3. The comparator that we mounted on the chuck should be turned 360-degree with the chuck and turret should be zeroed by that turning according to changing rate of comparator.

CUTTING SPEED AND REVOLUTION THAT ARE NEEDED FOR USING (RUNNING) YOUR U-DRILLS MORE PRODUCTIVELY

| Grup No. | Material | Material Type | Cutting Speed Vc (mm/m) |
|----------|--|------------------------|--------------------------|
| 1 | Non-alloy steel and free cutting steel | C1010. Automat etc. | 220 |
| 2 | Low alloy steel and cast steel | C1030 - 106 etc. | 200 |
| 3 | Alloy steel and tool steel | CK-45, 4140, 7131 etc. | 170 |
| 4 | Hot Work Steel and Stainless Steel | Impax etc. | 150 |

P.S. : The cutting speed may be concerned with the type of the insert that you use.

Fistly, choose the material to make calculation of revolution. You should multiply the cutting speed (Vc) of the material that you chose by 1000 and divide by 3.14. You should divide the value that you found by the diameter of U-Drill. For Example : If our material is alloy steel and tool steel (3rd group), diameter of the U-Drill is 25 mm, cutting speed is 170, we should calculate as following; $170 \times 1000 = 170000 / 3.14 = 54140$, $54140 / 25 = 2166$ rpm is the result that we found (Spindle Speed) Feed rate of the lathe is concerned with the U-Drill that you will use and changes between 0.05 and 0.10. The user sets it according to cut of cutting insert.

FEED CALCULATION FOR CENRAL MACHINE :

2166 spindle speed, that we found as a result of above mentioned calculation, should be multiplied by cutting insert feed (mm/r) between 0.05 and 0.10 feed choisses. Example 1 : $2166 \times 0.05 = 108$
Example 2 : $2166 \times 0.10 = 217$ The results 108 and 217 are the feed mm/m calculation for central machine.

FREZELEME İŞLEMİNDE DEVİR ve İLERLEME HESABI

| Vc. | S | D | F | Z | fz | FORMÜLLER |
|--|----------------------------|--------------------------|----------|------------------------------------|---|---|
| Kesme Hızı (Uç Kutusunun Arkasından Okuyunuz) | İş Mili Devir Sayısı | Tarama Kafası Çapı | İlerleme | Tarama Kafası Ağız Sayısı | Diş Başına Düşen İlerleme Miktarı (Uç Kutusunun Arkasından Okuyunuz) | Devir Hesabı : $S=(Vc \times 1000) / (3,14 \times D)$ İlerleme Hesabı : $F=S \times Z \times fz$ |

Örnek : D=50 mm çapında, Z=5 ağızlı tarama kafası ile frezeleme yapacağız. Kesici uç kutusunun arkasından kesme hızı Vc=200m/dk. olarak verilmiş olsun. Tezgaha girilecek devri hesaplayalım: **Vc=200 m/dk. D=50 mm** S = Öncelikle Kesme Hızı 1000 ile çarpılır, çıkan sonuç 3,14 sayısına bölünür, buradan çıkan sonuç da tarama kafası çapına bölünür.

$S=200 \times 1000 = 200000 \rightarrow 200000/3,14=63663 \rightarrow 63663/50=1273$ devir **S=1273 dev/dakika** devri bulduktan sonra ilerlemeyi bulalım : **Z=5** ağızlı tarama kafası olsun **fz=0,12** olarak uç kutusunun arkasından okunmuş olsun F= yukarıda bulmuş olduğumuz devir sayısı ile ağız sayısı çarpılır, çıkan sonuç diş başına düşen ilerleme miktarı ile çarpılır.

$F=1273 \times 5 = 6365 \rightarrow 6365 \times 0,12 = 763$ $F=763$ mm/dakika

Tezgaha girilecek olan devir = S 1273 Tezgaha girilecek olan ilerleme : **F 763 ortalama değerdir.**

Not: Vc ve fz değerlerinin uç kutusunun arkasından verilmiş olması gerekir. Eğer bu değerler uç kutusunun üzerinde yoksa, kesici ucun katalogundan bulunuz. İşleyeceğiniz malzeme çelik ise P, paslanmaz çelik ise M, dökme demir ise K bölümünde yazılı olan Vc ve fz değerlerini okuyun.

CALCULATING SPINDLE SPEED and FEED RATE FOR MILLING PROCESS

| Vc. | S | D | F | Z | fz | FORMULAS |
|---|------------------------------|-----------------------------|--------------|---------------------------------|--|--|
| Cutting Speed (Please read from the back- side of cutting insert box) | Spindle Revolution rpm | Milling Tool Diameter | Feed Rate | Number of Effective Tooth | Feed Per Tooth (Please Read From The Back Side of Cutting Insert Box) | Calculation of Revolution : $S=(Vc \times 1000) / (3,14 \times D)$ Feed Rate Calculation : $F=S \times Z \times fz$ |

For Example : We will make milling with milling tool whose diameter is D 50 mm, whose teeth number is Z=5. The spindle revolution was written as Vc=200m/mn at the back side of cutting insert box. Let's calculate the revolution that should be entered to the milling machine : Vc=200 m/mn D=50 mm

S = Firstly Cutting Speed is multiplied with 1000, the result should be divided by 3.14 , the last result should be divided by diameter of milling tool.

$S = 200 \times 1000 = 200000 \rightarrow 200000/3,14 = 63663 \rightarrow 63663/50 = 1273$ rev $S=1273$ rev / mn

After finding spindle revolution, let's find feed rate : milling tool with Z=5 teeth and we read fz=0,12 from the back side of cutting insert box.

F = Tooth number should be multiplied with revolution, the result should be multiplied with feed per tooth.

$F = 1273 \times 5 = 6365 \rightarrow 6365 \times 0,12 = 763$ $F = 763$ mm / mn

Revolution that should be entered to the milling machine = S 1273 Feed Rate that should be entered to the milling machine = F 763 average value.

P.S : The values Vc and fz has to be written at the back side of the cutting insert. If these values were not written on the cutting insert box, please find them from cutting insert catalogue. If the material that you will work is steel, please read Vc and fz values that were written on the part P, if it is stainless steel please read from the part M, if it is cast iron please read from the part K.

ALTLIKLAR / SHIMS

| ÜRÜN RESMİ/PICTURE | ÜRÜN KODU/CODE | ÜRÜN DETAYI / PRODUCT DETAIL | |
|--------------------|--------------------------------------|--|---|
| | AATN-2-0001 | S-SİSTEM için / For S-SYSTEM | TCMT 16 ALTLIK / SHIM |
| | AATN-2-0002 | T-M SİSTEM için / For T-M SYSTEM C-SİSTEM için / For C-SYSTEM | TNMG 16 ALTLIK / SHIM TNGN 16 ALTLIK / SHIM |
| | AATN-3-0025 | P-SİSTEM için / For P-SYSTEM | TNMG 16 ALTLIK / SHIM |
| | AATN-3-0015 | T-M-P SİSTEM için / For T-M SYSTEM | TNMG 22 ALTLIK / SHIM |
| | AATN-2-0020 | DİŞ VİDA 16 ALTLIK / For THREADING 16 SHIM | |
| | AATN-2-0004 | DİŞ VİDA 22 ALTLIK / For THREADING 22 SHIM | |
| | ATS-16E | DİŞ VİDA 16, DİŞ ÇAP SAĞ - DELİK İÇİ SOL ALTLIK / For THREADING SYSTEM 16 SHIM, EXTERNAL RIGHT-INTERNAL LEFT | |
| | ATS-16I | DİŞ VİDA 16, DİŞ ÇAP SOL - DELİK İÇİ SAĞ ALTLIK / For THREADING SYSTEM 16 SHIM, EXTERNAL LEFT-INTERNAL RIGHT | |
| | ATS-22E | DİŞ VİDA 22, DİŞ ÇAP SAĞ - DELİK İÇİ SOL ALTLIK / For THREADING SYSTEM 22 SHIM, EXTERNAL RIGHT-INTERNAL LEFT | |
| | ATS-22I | DİŞ VİDA 22, DİŞ ÇAP SOL - DELİK İÇİ SAĞ ALTLIK / For THREADING SYSTEM 22 SHIM, EXTERNAL LEFT-INTERNAL RIGHT | |
| | ATS-27E | DİŞ VİDA 27, DİŞ ÇAP SAĞ - DELİK İÇİ SOL ALTLIK / For THREADING SYSTEM 27 SHIM, EXTERNAL RIGHT-INTERNAL LEFT | |
| | ATS-27I | DİŞ VİDA 27, DİŞ ÇAP SOL - DELİK İÇİ SAĞ ALTLIK / For THREADING SYSTEM 27 SHIM, EXTERNAL LEFT-INTERNAL RIGHT | |
| | AACN-2-0001 | S-SİSTEM için / For S-SYSTEM T-SİSTEM için / For T-SYSTEM | CCMT 09 ALTLIK / SHIM CNMG 09 ALTLIK / SHIM |
| | AACN-2-0002 | P-SİSTEM için / For P-SYSTEM | CNMG 09 ALTLIK / SHIM |
| | AACN-2-0003 | S-SİSTEM için / For S-SYSTEM | CCMT 12 ALTLIK / SHIM |
| | AACN-3-0001 | T-M-P SİSTEM için / For T-M-P SYSTEM C-SİSTEM için / For C-SYSTEM | CNMG 12 ALTLIK / SHIM CNGN 12 ALTLIK / SHIM |
| | AACN-3-0002 | T-P SİSTEM için / For T-P SYSTEM | CNMG 16 ALTLIK / SHIM |
| | AACN-3-0003 | T-P SİSTEM için / For T-P SYSTEM | CNMG 19 ALTLIK / SHIM |
| | AACN-3-0008 | T-P SİSTEM için / For T-P SYSTEM | CNMG 25 ALTLIK / SHIM |
| | AAWN-3-0001 | T-M-P SİSTEM için / For T-M-P SYSTEM | WNMG 08 ALTLIK / SHIM |
| AAWN-SW317 | T-M-P SİSTEM için / For T-M-P SYSTEM | WNMG 06 ALTLIK / SHIM | |
| | AKS-16L | C-SİSTEM için / For C-SYSTEM | KNUX-L 16 ALTLIK / SHIM |
| | AKS-16R | C-SİSTEM için / For C-SYSTEM | KNUX-R 16 ALTLIK / SHIM |
| | AASN-2-0001 | S-SİSTEM için / For S-SYSTEM | SCMT 09 ALTLIK / SHIM |
| | AASN-2-0002 | P-SİSTEM için / For P-SYSTEM | SNMG 09 ALTLIK / SHIM |
| | AASN-2-0004 | S-SİSTEM için / For S-SYSTEM | SCMT 12 ALTLIK / SHIM |
| | AASN-3-0004 | T-P SİSTEM için / For T-P SYSTEM C-SİSTEM için / For C-SYSTEM | SNMG 12 ALTLIK / SHIM SNGN 12 ALTLIK / SHIM |
| | AASN-3-0023 | T-P SİSTEM için / For T-P SYSTEM | SNMG 15 ALTLIK / SHIM |
| | AASN-3-0005 | T-P SİSTEM için / For T-P SYSTEM | SNMG 19 ALTLIK / SHIM |
| | AASN-3-0020 | T-P SİSTEM için / For T-P SYSTEM | SNMG 25 ALTLIK / SHIM |
| | AASN-20020 | PSDNN KARTUŞ için / For PSDNN CARTRIDGE | SNMG 12 ALTLIK / SHIM |
| | AADN-2-0001 | S-SİSTEM için / For S-SYSTEM T-SİSTEM için / For T-SYSTEM | DCMT 11 ALTLIK / SHIM DNMG 11 ALTLIK / SHIM |
| | AADN-SD317 | P-SİSTEM için / For P-SYSTEM | DNMG 11 ALTLIK / SHIM |
| | AADN-3-0001 | T-M-P SİSTEM için / For T-M-P SYSTEM C-SİSTEM için / For C-SYSTEM | DNMG 15 ALTLIK / SHIM DNGN 15 ALTLIK / SHIM |
| | AADN-2-0003 | T-SİSTEM için / For T-SYSTEM | DNMG 15 KALIN ALTLIK / THICK SHIM |
| | AAVN-2-0002 | S-SİSTEM için / For S-SYSTEM T-SİSTEM için / For T-SYSTEM | VBMT 16, VCMT 16 ALTLIK / SHIM VNMG 16 ALTLIK / SHIM |



BASKI PABUÇLARI / CLAMPS

| ÜRÜN RESMİ/PICTURE | ÜRÜN KODU/CODE | ÜRÜN DETAYI / PRODUCT DETAIL |
|--------------------|----------------|---|
| | ATK-01 | T-SİSTEM için / For T-SYSTEM DNMG 11, WNMG 06, TNMG 16, CNMG 09 BASKI PABUCU / CLAMP |
| | ATK-02 | T-SİSTEM için / For T-SYSTEM CNMG 12, WNMG 08, TNMG 22, DNMG 15, SNMG 12 BASKI PABUCU / CLAMP |
| | ATK-03 | T-SİSTEM için / For T-SYSTEM VNMG 16 BASKI PABUCU / CLAMP |
| | ATK-04 | T-SİSTEM için / For T-SYSTEM CNMG 16, SNMG 15 BASKI PABUCU / CLAMP |
| | AMK-01 | M-SİSTEM için / For M-SYSTEM WNMG 06 BASKI PABUCU / CLAMP |
| | AMK-02 | M-SİSTEM için / For M-SYSTEM DELİK İÇİ / INTERNAL Ø20 TNMG 16 Ø25 MT-NR/L 16 BASKI PABUCU / CLAMP |
| | AMK-03 | M-SİSTEM için / For M-SYSTEM DNMG 11, CNMG 12 BASKI PABUCU / CLAMP |
| | AMK-04 | M-SİSTEM için / For M-SYSTEM DNMG 15, TNMG 16-22 BASKI PABUCU / CLAMP |
| | AMK-05 | M-SİSTEM için / For M-SYSTEM WNMG 08 BASKI PABUCU / CLAMP |
| | ACK-01 | C-SİSTEM için / For C-SYSTEM KNUX-R BASKI PABUCU / CLAMP |
| | ACK-02 | C-SİSTEM için / For C-SYSTEM KNUX-L BASKI PABUCU / CLAMP |
| | ACK-03 | C-SİSTEM için / For C-SYSTEM 154.91 DIŞ ÇAP ve DELİK İÇİ / EXTERNAL and INTERNAL Ø25-Ø32 BASKI PABUCU / CLAMP |
| | ACK-04 | P-C SİSTEM için / For P-C SYSTEM CTFPR KARTUŞ BASKI PABUCU / CARTRIDGE CLAMP |
| | ACK-05 | P-C SİSTEM için / For P-C SYSTEM FREZELEME ve DIŞ VİDA AÇMA TAKIMLARINA GÖRE İLAVE BASKI PABUCU ADDITIONAL LITTLE CLAMP for MILLING and THREADING CLAMP |
| | ACK-06 | C-SİSTEM için / For C-SYSTEM 154.91 DELİK İÇİ / INTERNAL Ø16-Ø20 BASKI PABUCU / CLAMP |
| | ACK-07 | C-SİSTEM için / For C-SYSTEM SERAMİK CNGN, SNGN, DNGN YEDEK TAKIMI SPARE PART SET of CERAMIC CNGN, SNGN, DNGN |
| | ACK-08 | C-SİSTEM için / For C-SYSTEM SERAMİK TNGN, YEDEK TAKIMI SPARE PART SET of CERAMIC TNGN |
| | ACK-09 | P-SİSTEM için / For P-SYSTEM CNMG 16-19, SNMG 15-19 İLAVE BÜYÜK BASKI PABUCU ADDITIONAL BIG CLAMP |
| | ACK-10 | C-SİSTEM FREZELEME için For C-SYSTEM MILLING SPKN 12 ve Ø50-Ø63 TPKN 16 BASKI PABUCU / CLAMP (M8x8) |
| | ACK-11 | C-SİSTEM FREZELEME için For C-SYSTEM MILLING Ø80-Ø100 TPKN 16-TPKN 22, OFKR 07, HNMX 09 BASKI PABUCU / CLAMP (M8x10) |
| | ACK-12 | C-SİSTEM için For C-SYSTEM CTSPR KARTUŞ BASKI PABUCU / CARTRIDGE CLAMP |
| | ACK-15 | S-SİSTEM FREZELEME için For S-SYSTEM MILLING RD.. 10-12 BASKI PABUCU / CLAMP |

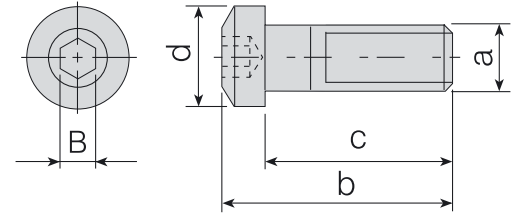

BASKI PABUÇ VİDALARI / CLAMP SCREWS

| Takım Kodu Ordering Code | a (M) | b | c | d | B | Ürün Detayı Product Detail |
|-----------------------------|---------|------|----|------|---|--|
| AKV-01-M5X22 | M5x0.8 | 25.1 | 22 | 11 | 3 | T-SİSTEM için / For T- SYSTEM DNMG 11, WNMG 06, TNMG 16 |
| AKV-02-M6X22 | M6x1.0 | 25.3 | 22 | 11 | 3 | T-SİSTEM için / For T- SYSTEM CNMG 12, WNMG 08, TNMG 22, DNMG 15, SNMG 12, VNMG 16 |
| | | | | | | M-SİSTEM için / For M- SYSTEM TNMG 16, TNMG 22 KANAL KATERİ için / For EXTERNAL GROOVING 2mm Dış Çap Kanal Kater Vidası / External Grooving Tools Screw |
| AKV-03-M6X22 | M6x1.0 | 25.3 | 22 | 10 | 3 | M-SİSTEM için / For M- SYSTEM WNMG 08 |
| AKV-04-M5X17 | M5x0.8 | 20 | 17 | 8.5 | 3 | M-SİSTEM için / For M- SYSTEM S20R MT-NR/L 16, S20R-S25S MWLNR/L 06, S25S MDUNR/L 11-Dış Çap / External MWLNR 06 |
| AKV-05-M6X25 | M6x1.0 | 29.5 | 25 | 13.8 | 4 | T-SİSTEM için / For T- SYSTEM Eski Ürün Vidası / Old Products Screws CNMG 16, SNMG 15 |
| AKV-06-M6X20 | M6x1.0 | 26.5 | 20 | 10.6 | 4 | C-SİSTEM için / For C-SYSTEM KNUX 16 |
| AKV-07-M6X22 | M6x1.0 | 23.5 | 22 | 8.5 | 3 | C-SİSTEM için / For C-SYSTEM ADKT-154.91, AIKT-154.91-R/L-32 |
| AKV-10-M6X14 | M6x1.0 | 16 | 14 | 8.8 | 4 | C-SİSTEM için / For C-SYSTEM AIKT-154.91-R/L-16, AIKT-154.91-R/L-20, AIKT-154.91-R/L-25 |
| AKV-11-M8X29 | M8x1.25 | 33.6 | 29 | 11 | 4 | C-SİSTEM için / For C-SYSTEM TNGN 16, CNGN 12, DNGN 15, SNGN 12 |
| AKV-17-M5X15 | M5x0.8 | 18 | 15 | 8.55 | 3 | M-SİSTEM için / For M- SYSTEM S16P MWLNR/L 06 |
| AKV-19-M7X25 | M7x1.0 | 29.6 | 25 | 14 | 4 | T-SİSTEM için / For T- SYSTEM Yeni / New CNMG 16, SNMG 15 |
| AKV-20-M6X19 | M6x1.0 | 22 | 19 | 11 | 3 | M-SİSTEM için / For M- SYSTEM S25S MDUNR/L 15 |
| AKV-21-M6X18 | M6x1.0 | 20 | 18 | 8.5 | 3 | C-SİSTEM için / For C-SYSTEM AIKT-154.91-R/L-25 |

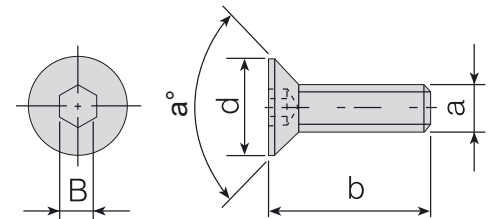

ALTLIK VİDALARI / SHIM SCREWS

| Takım Kodu Ordering Code | a (M) | b | d | B | a° | Ürün Detayı Product Detail |
|-----------------------------|--------|----|-----|---|-----|--|
| AAV-01-M3x10 | M3x0.5 | 10 | 5.9 | 2 | 90° | T-SİSTEM için / For T-SYSTEM WNMG 06, KNUX 16 |
| AAV-02-M5X12 | M5x0.8 | 12 | 7 | 3 | 56° | T-SİSTEM için / For T-SYSTEM CNMG 12, WNMG 08, TNMG 22, DNMG 15, SNMG 12 |
| AAV-05-M6X15 | M6x1.0 | 16 | 9 | 4 | 60° | T-SİSTEM için / For T-SYSTEM CNMG 16, SNMG 15 |
| AKV-12-M5X12 | M5x0.8 | 12 | 7.8 | 3 | 90° | C-SİSTEM için / For C-SYSTEM CTSPR Baskı Pabuç Vidası / Clamp Screw |
| AKV-16-M6X16 | M6x1.0 | 16 | 10 | 4 | 76° | C-SİSTEM için / For C-SYSTEM CTFPR 13CS 16 Baskı Pabuç Vidası / Clamp Screw |

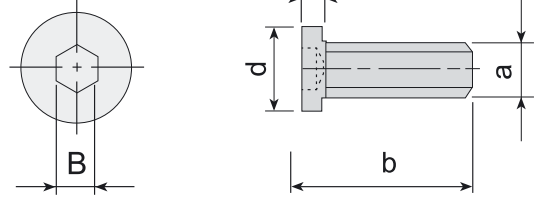

ALTLIK VİDALARI / SHIM SCREWS

| Takım Kodu Ordering Code | a (M) | b | c | d | B | Ürün Detayı Product Detail | |
|-----------------------------|--------|----|-----|-----|---|-------------------------------|---|
| | | | | | | T-SİSTEM için / For T-SYSTEM | TNGN 16 |
| AAV-03-M5X12 | M5X0.8 | 12 | 1.4 | 6 | 3 | T-SİSTEM için / For T-SYSTEM | TNMG 16 |
| | | | | | | C-SİSTEM için / For C-SYSTEM | TNGN 16 |
| AAV-04-M5X12 | M5X0.8 | 12 | 1.2 | 6.5 | 3 | T-SİSTEM için / For T-SYSTEM | VNMG 16, DNMG 11, CNMG 09 |
| AAV-09-M5X9 | M5X0.8 | 9 | 1.4 | 6 | 3 | T-SİSTEM için / For T-SYSTEM | S25S TCLNR/L 09, S25S TDUNR/L 11, S25S TDQNR/L 11 |

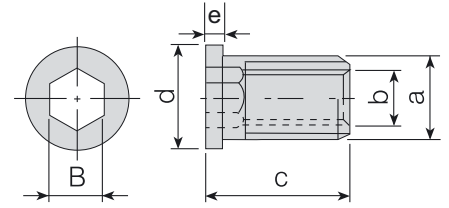

BUKSE VİDALAR / BUKSE SCREWS

| Takım Kodu Ordering Code | a (M) | b | c | d | B | e | Ürün Detayı Product Detail | |
|-----------------------------|---------|-----------|------|-----|-----|------|-------------------------------|---|
| | | | | | | | S-SİSTEM için / For S- SYSTEM | CCMT 09, DCMT 11, VBMT 16, VCMT 16, TCMT 16, SCMT 09, 16 ER/L, 16 IR/L |
| AAV-06-M3.5X11 | M5x0.5 | M3.5x0.6 | 11.3 | 6 | 3.5 | 1.2 | S-SİSTEM için / For S- SYSTEM | CCMT 09, DCMT 11, VBMT 16, VCMT 16, TCMT 16, SCMT 09, 16 ER/L, 16 IR/L |
| AAV-07-M4.5X11 | M6X0.75 | M4.5X0.75 | 12 | 7.5 | 4.5 | 1.6 | S-SİSTEM için / For S- SYSTEM | CCMT 12, SCMT 12, 22 ER/L, 22 IR/L |
| AAV-08-M3.5X8 | M5X0.5 | M3.5x0.6 | 8 | 6 | 3.5 | 1.2 | S-SİSTEM için / For S- SYSTEM | Ø25 DCMT 11, Ø25-Ø32 CCMT 09, Ø25 TCMT 16, S25S-S32T SVJBR/L 16, |
| AAV-10-M4.5X8 | M6X0.75 | M4.5X0.75 | 8 | 7.5 | 4.5 | 1.05 | S-SİSTEM için / For S- SYSTEM | Ø25-Ø32 CCMT 12, Ø25-Ø32 SCMT 12, SSDCN 1616 H12, SSSCR/L 1616 H12, SIR/L S25R 22 |

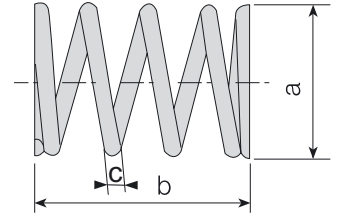
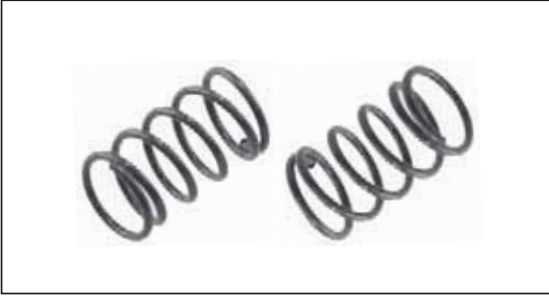

BASKI YAYI / CLAMP SPRING

| Takım Kodu Ordering Code | BASKI YAYI / CLAMP SPRING | | | Ürün Detayı Product Detail | |
|-----------------------------|---------------------------|------|-----|-------------------------------|--|
| | a | b | c | | |
| AKY-01 | 7.7 | 11.2 | 0.9 | T-SİSTEM için / For T-SYSTEM | CNMG 12, WNMG 08, TNMG 22, DNMG 15, SNMG 12, VNMG 16 |
| AKY-02 | 8.5 | 13.5 | 0.7 | C-SİSTEM için / For C-SYSTEM | KNUX 16 |

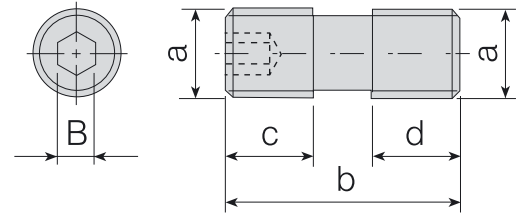

BASKI PABUÇ VİDALARI / CLAMP SCREWS

| Takım Kodu Ordering Code | BASKI PABUÇ VİDALARI / CLAMP SCREWS | | | | | | Ürün Detayı Product Detail | |
|-----------------------------|-------------------------------------|----|-----|-----|-----|--|--------------------------------------|--|
| | a (M) | b | c | d | B | | | |
| AKV-13-M8X1X16 | M8x1.0 | 16 | 6.8 | 6.8 | 4 | C-SİSTEM FREZELEME için / MILLING For C-SYSTEM | SPKN 12 ve Ø63 TPKN 16 | |
| AKV-14-M-8X1X18 | M8x1.0 | 18 | 8 | 8 | 4 | C-SİSTEM FREZELEME için / MILLING For C-SYSTEM | Ø80-Ø100 TPKN 16 ve Ø63-Ø315 TPKN 22 | |
| AKV-15-M8X1X20 | M8x1.0 | 20 | 8.5 | 8.5 | 4 | C-SİSTEM FREZELEME için / MILLING For C-SYSTEM | OFKR 07, HNMX 09 | |
| AKV-18-M5X14 | M5x0.8 | 15 | 5 | 6.8 | 2.5 | C-SİSTEM FREZELEME için / MILLING For C-SYSTEM | SN19 | |
| AKV-22-M8X1X14 | M8x1.0 | 14 | 6.8 | 4.8 | 4 | C-SİSTEM FREZELEME için / MILLING For C-SYSTEM | Ø50 TPKN 16 | |

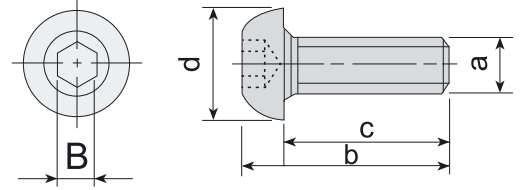

KANAL KATER ve MANTAR VİDALAR / GROOVING TOOL and CLAMP SCREWS

| Takım Kodu Ordering Code | a (M) | b | c | d | B | Ürün Detayı Product Detail | Ürün Detayı Product Detail |
|-----------------------------|---------|------|----|------|---|---|---|
| 1904-M8X1X20 | M8X1.0 | 25.9 | 20 | 11.3 | 4 | S-SİSTEM için / For S- SYSTEM | RCMT 32 Sıkma Vidası / Clamp Screw |
| 2004-M8X1X20 | M8X1.0 | 25.9 | 20 | 11.4 | 4 | KANAL KATERİ için / For EXTERNAL GROOVING | Kanal Kater Vidası / External Grooving Tools Screw |
| 2004-M8X20 | M8X1.25 | 30 | 25 | 25 | 4 | KANAL KATERİ için / For EXTERNAL GROOVING | Eski Kanal Kater Vidası / Old External Grooving Tools Screw |
| AKV-08-M6X12 | M6x1.0 | 17 | 12 | 14.3 | 4 | C-SİSTEM FREZELEME için / MILLING For C- SYSTEM | Baskı ve Sıkma Vidası, Mantar Vida / Clamp Screw |
| AKV-09-M8X18 | M8X1.0 | 24 | 18 | 17.2 | 5 | C-SİSTEM FREZELEME için / MILLING For C- SYSTEM | Baskı ve Sıkma Vidası, Mantar Vida / Clamp Screw |

LEVYELER / LEVERS

| Ürün Resmi Product Picture | Ürün Kodu Product Code | Ürün Detayı Product Detail | Ürün Detayı Product Detail |
|-------------------------------|---------------------------|-------------------------------|---|
| | APL-01 | P-SİSTEM için / For P-SYSTEM | CNMG 09, DNMG 11, SNMG 09, TNMG 16, WNMG 06 LEVYESİ / LEVER |
| | APL-02 | P-SİSTEM için / For P-SYSTEM | CNMG 12, SNMG 12, TNMG 22, WNMG 08 LEVYESİ / LEVER |
| | APL-03 | P-SİSTEM için / For P-SYSTEM | DNMG 15 LEVYESİ / LEVER |
| | APL-04 | P-SİSTEM için / For P-SYSTEM | CNMG 16, SNMG 15 LEVYESİ / LEVER |
| | APL-05 | P-SİSTEM için / For P-SYSTEM | CNMG 19, SNMG 19 LEVYESİ / LEVER |
| | APL-06 | P-SİSTEM için / For P-SYSTEM | CNMG 25, SNMG 25 LEVYESİ / LEVER |
| | APL-07 | P-SİSTEM için / For P-SYSTEM | S16P PCLNR/L 09, S16P PTUNR/L 16 LEVYESİ / LEVER |

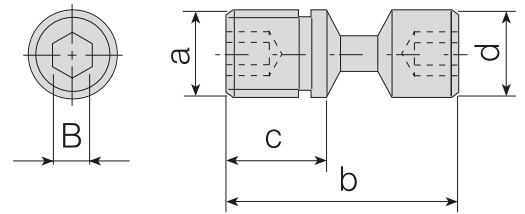

LEVYE VİDALARI / LEVER SCREWS

| Takım Kodu Ordering Code | a (M) | b | c | d | B | Ürün Detayı Product Detail | Ürün Detayı Product Detail |
|-----------------------------|---------|------|-----|------|-----|-------------------------------|---|
| ALV-01-M6X14 | M6x1.0 | 14 | 10 | 5.85 | 2.5 | P-SİSTEM için / For P-SYSTEM | S20R PCLNR/L 09, S20R PDUNR/L 11, S20R PDQNR/L 11, S20R PWLNR/L 06, S20R PTUNR/L 16 |
| ALV-02-M6X17 | M6x1.0 | 17 | 10 | 5.85 | 2.5 | P-SİSTEM için / For P-SYSTEM | CNMG 09, DNMG 11, SNMG 09, TNMG 16, WNMG 06 |
| ALV-03-M8X19 | M8X1.0 | 19.8 | 11 | 7.9 | 3 | P-SİSTEM için / For P-SYSTEM | CNMG 12, SNMG 12, TNMG 22, WNMG 08, DNMG 15 |
| ALV-04-M8X22 | M8X1.0 | 21.5 | 13 | 7.75 | 3 | P-SİSTEM için / For P-SYSTEM | CNMG 16, SNMG 15 |
| ALV-05-M10X27 | M10X1.0 | 27.5 | 15 | 9.9 | 4 | P-SİSTEM için / For P-SYSTEM | CNMG 19, SNMG 19 |
| ALV-06-M12X36 | M12X1.0 | 36 | 20 | 12 | 5 | P-SİSTEM için / For P-SYSTEM | CNMG 25, SNMG 25 |
| ALV-07-M6X13 | M6X0.1 | 12.6 | 6.5 | 5.9 | 2.5 | P-SİSTEM için / For P-SYSTEM | S16P PCLNR/L 09, S16P PCTUR/L 16 |
| ALV-08-M8X15 | M8X1.0 | 15 | 10 | 7.9 | 3 | P-SİSTEM için / For P-SYSTEM | S25S PCLNR/L 12, S25S PDUNR/L 15, S25S PSKNR/L 12 |

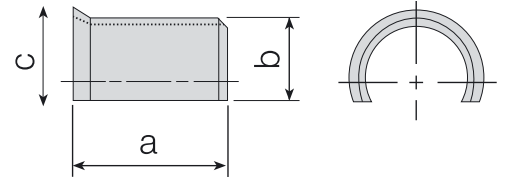

ALTLIK YAYLARI / SHIM SPRINGS

| Takım Kodu Ordering Code | Ürün Detayı Product Detail | | | Ürün Detayı Product Detail |
|-----------------------------|-------------------------------|-----|------|--|
| | a | b | c | |
| AAV-01 | 5.6 | 4.9 | 6 | P-SİSTEM için / For P-SYSTEM CNMG 09 ,DNMG 11, SNMG 09, TNMG 16, WNMG 06 |
| AAV-02 | 6 | 6.9 | 7.9 | P-SİSTEM için / For P-SYSTEM CNMG 12, SNMG 12, TNMG 22, WNMG 08, DNMG 15 |
| AAV-03 | 8.9 | 8 | 9.5 | P-SİSTEM için / For P-SYSTEM CNMG 16, SNMG 15 |
| AAV-04 | 11 | 9.8 | 10.7 | P-SİSTEM için / For P-SYSTEM CNMG 19, SNMG 19 |
| AAV-05 | 12 | 13 | 15 | P-SİSTEM için / For P-SYSTEM CNMG 25, SNMG 25 |

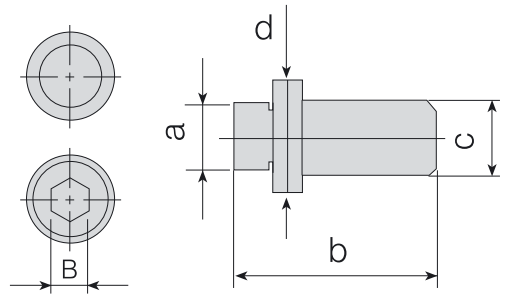

PİMLER / PINS

| Takım Kodu Ordering Code | Ürün Detayı Product Detail | | | | | Ürün Detayı Product Detail |
|-----------------------------|-------------------------------|------|-----|-----|---|---|
| | a | b | c | d | B | |
| APM-01 | 3.55 | 18 | 5 | 6 | - | M-SİSTEM için / For M- SYSTEM DELİK İÇİ / INTERNAL Ø32-Ø40 TNMG 16 - DIŞ ÇAP / EXTERNAL TNMG 16 |
| APM-02 | 5 | 18 | 6 | 7.3 | - | M-SİSTEM için / For M- SYSTEM TNMG 22, WNMG 08 |
| APM-03 | 3.5 | 12 | 5 | 6.5 | - | M-SİSTEM için / For M- SYSTEM S20R MTFNR/L 16, S20R MT-NR/L 16, S20R MTUNR/L 16, S20R MTQNR/L 16, S20R MDUNR/L 11 |
| APM-04 | 5 | 15 | 6 | 7.3 | - | M-SİSTEM için / For M- SYSTEM S32T MCLNR/L 12, DNMG 15, S25S MWLNR/L 08 |
| APM-05 | 5 | 11.5 | 6.5 | 6.5 | 3 | M-SİSTEM için / For M- SYSTEM MSYNR KARTUŞ için / for MSYNR CARTRIDGE SNMG 12 |
| APM-06 | 3 | 15.7 | - | - | - | C-SİSTEM için / For C- SYSTEM 154.91 |
| APM-07 | 3.5 | 11.5 | 6.5 | 6.5 | 3 | M-SİSTEM için / For M- SYSTEM S20R ET-NR 16 |
| APM-08 | 3.5 | 12 | 5 | 5.4 | - | M-SİSTEM için / For M- SYSTEM S25S MWLNR/L 06, Diş Çap / External MWLNR 06 |
| APM-09 | 3.5 | 10 | 5 | 5.4 | - | M-SİSTEM için / For M- SYSTEM S16P MWLNR/L 06 |
| APM-10 | 3.5 | 11 | 5 | 5.4 | - | M-SİSTEM için / For M- SYSTEM S20R MWLNR/L 06 |
| APM-11 | 3.5 | 11 | 5 | 6.5 | - | M-SİSTEM için / For M- SYSTEM S20R MTQNR/L 16 |
| APM-12 | 5 | 12 | 6 | 7.3 | - | M-SİSTEM için / For M- SYSTEM S20R MCLNR/L 12, S25S MCLNR/L 12-Z |
| APM-13 | 5 | 14 | 6 | 7.3 | - | M-SİSTEM için / For M- SYSTEM S25S MCLNR/L 12 |
| APM-14 | 3.55 | 15 | 5 | 6 | - | M-SİSTEM için / For M- SYSTEM S25S MTFNR/L 16, S25S MT-NR/L 16, S25S MTUNR/L 16, S25S MTQNR/L 16 |

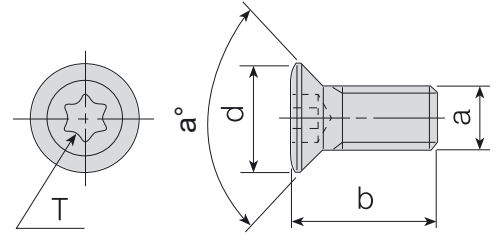

TORK VİDALARI / TORX SCREWS

| Takım Kodu Ordering Code | a (M) | b | T | d | a° | Ürün Detayı Product Detail | |
|-----------------------------|-----------|------|----|------|----|-------------------------------|------------------------|
| 3006-M1.8X4 | M1.8X0.35 | 4 | 6 | 2.45 | 60 | S-SİSTEM için / For S-SYSTEM | TORK VİDA / TORX SCREW |
| 3006-M2X4 | M2X0.4 | 4.3 | 6 | 2.7 | 60 | S-SİSTEM için / For S-SYSTEM | TORK VİDA / TORX SCREW |
| 4006-M2X5 | M2X0.4 | 5 | 7 | 3 | 55 | S-SİSTEM için / For S-SYSTEM | TORK VİDA / TORX SCREW |
| 4006-M2X5 | M2X0.4 | 5 | 6 | 2.8 | 55 | S-SİSTEM için / For S-SYSTEM | TORK VİDA / TORX SCREW |
| 3007-M2.2X5 | M2.2X0.45 | 5.2 | 7 | 3.15 | 60 | S-SİSTEM için / For S-SYSTEM | TORK VİDA / TORX SCREW |
| 1008-M2.5X5 | M2.5X0.45 | 5.5 | 8 | 3.5 | 45 | S-SİSTEM için / For S-SYSTEM | TORK VİDA / TORX SCREW |
| 1008-M2.5X7 | M2.5X0.45 | 7 | 8 | 3.6 | 45 | S-SİSTEM için / For S-SYSTEM | TORK VİDA / TORX SCREW |
| 1108-M2.5X6 | M2.5X0.45 | 6.5 | 8 | 3.9 | R | S-SİSTEM için / For S-SYSTEM | TORK VİDA / TORX SCREW |
| 3008-M2.5X5 | M2.5X0.45 | 5 | 8 | 3.5 | 60 | S-SİSTEM için / For S-SYSTEM | TORK VİDA / TORX SCREW |
| 3008-M2.5X6 | M2.5X0.45 | 6 | 8 | 3.5 | 60 | S-SİSTEM için / For S-SYSTEM | TORK VİDA / TORX SCREW |
| 4008-M2.5X4 | M2.5X0.45 | 4 | 8 | 3.5 | 45 | S-SİSTEM için / For S-SYSTEM | TORK VİDA / TORX SCREW |
| 4008-M2.5X4.5 | M2.5X0.45 | 4.5 | 8 | 3.5 | 45 | S-SİSTEM için / For S-SYSTEM | TORK VİDA / TORX SCREW |
| 4008-M2.5X6 | M2.5X0.45 | 5.8 | 8 | 3.5 | 45 | S-SİSTEM için / For S-SYSTEM | TORK VİDA / TORX SCREW |
| 1008-M3X6 | M3X0.5 | 6 | 8 | 4 | 45 | S-SİSTEM için / For S-SYSTEM | TORK VİDA / TORX SCREW |
| 1008-M3X8 | M3X0.5 | 8 | 8 | 3.9 | 45 | S-SİSTEM için / For S-SYSTEM | TORK VİDA / TORX SCREW |
| 3008-M3X7 | M3X0.5 | 7 | 8 | 4 | 55 | S-SİSTEM için / For S-SYSTEM | TORK VİDA / TORX SCREW |
| 4008-M3X8 | M3X0.5 | 8 | 8 | 4 | 60 | S-SİSTEM için / For S-SYSTEM | TORK VİDA / TORX SCREW |
| 4010-M3X6 | M3X0.5 | 6 | 10 | 4.2 | 45 | S-SİSTEM için / For S-SYSTEM | TORK VİDA / TORX SCREW |
| 4010-M3X8 | M3X0.5 | 8 | 10 | 4.2 | 45 | S-SİSTEM için / For S-SYSTEM | TORK VİDA / TORX SCREW |
| 1015-M3.5X11 | M3.5X0.6 | 11.1 | 15 | 5.3 | 60 | S-SİSTEM için / For S-SYSTEM | TORK VİDA / TORX SCREW |
| 1015-M3.5X14 | M3.5X0.6 | 14 | 15 | 5.3 | 45 | S-SİSTEM için / For S-SYSTEM | TORK VİDA / TORX SCREW |
| 1015-M3.5X16 | M3.5X0.6 | 16 | 15 | 5.3 | 55 | S-SİSTEM için / For S-SYSTEM | TORK VİDA / TORX SCREW |
| 1015-M3.5X9 | M3.5X0.6 | 9 | 15 | 5.3 | 60 | S-SİSTEM için / For S-SYSTEM | TORK VİDA / TORX SCREW |
| 1315-M3.5X11 | M3.5X0.6 | 10.6 | 15 | 7.9 | - | S-SİSTEM için / For S-SYSTEM | TORK VİDA / TORX SCREW |
| 1410-M3.5X9 | M3.5X0.6 | 8.2 | 10 | 4.75 | R | S-SİSTEM için / For S-SYSTEM | TORK VİDA / TORX SCREW |
| 1510-M3.5X7 | M3.5X0.6 | 7.1 | 10 | 5.1 | 55 | S-SİSTEM için / For S-SYSTEM | TORK VİDA / TORX SCREW |
| 1510-M3.5X9 | M3.5X0.6 | 9.1 | 10 | 5 | 55 | S-SİSTEM için / For S-SYSTEM | TORK VİDA / TORX SCREW |
| 1615-M3.5X10 | M3.5X0.6 | 10 | 15 | 5.8 | 60 | S-SİSTEM için / For S-SYSTEM | TORK VİDA / TORX SCREW |
| 1615-M3.5X11 | M3.5X0.6 | 11 | 15 | 5.8 | 60 | S-SİSTEM için / For S-SYSTEM | TORK VİDA / TORX SCREW |
| 1615-M3.5X15 | M3.5X0.6 | 15 | 15 | 5.8 | 60 | S-SİSTEM için / For S-SYSTEM | TORK VİDA / TORX SCREW |
| 3015-M3.5X9 | M3.5X0.6 | 8.8 | 15 | 5.4 | 60 | S-SİSTEM için / For S-SYSTEM | TORK VİDA / TORX SCREW |
| 4015-M3.5X10 | M3.5X0.6 | 9.8 | 15 | 5.3 | 60 | S-SİSTEM için / For S-SYSTEM | TORK VİDA / TORX SCREW |
| 4015-M3.5X11 | M3.5X0.6 | 10.7 | 15 | 5.3 | 60 | S-SİSTEM için / For S-SYSTEM | TORK VİDA / TORX SCREW |
| 4015-M3.5X12 | M3.5X0.6 | 12 | 15 | 5.3 | 60 | S-SİSTEM için / For S-SYSTEM | TORK VİDA / TORX SCREW |
| 4015-M3.5X14 | M3.5X0.6 | 13.7 | 15 | 5.3 | 60 | S-SİSTEM için / For S-SYSTEM | TORK VİDA / TORX SCREW |
| 4015-M3.5X8 | M3.5X0.6 | 7.9 | 15 | 5.3 | 55 | S-SİSTEM için / For S-SYSTEM | TORK VİDA / TORX SCREW |
| 4015-M3.5X9 | M3.5X0.6 | 8.7 | 15 | 5.3 | 60 | S-SİSTEM için / For S-SYSTEM | TORK VİDA / TORX SCREW |
| 1015-M4X11 | M4X0.7 | 10.8 | 15 | 6.8 | R | S-SİSTEM için / For S-SYSTEM | TORK VİDA / TORX SCREW |
| 1115-M4X10 | M4X0.7 | 10 | 15 | 5.9 | R | S-SİSTEM için / For S-SYSTEM | TORK VİDA / TORX SCREW |
| 1315-M4X11 | M4X0.7 | 11.1 | 15 | 5 | 45 | S-SİSTEM için / For S-SYSTEM | TORK VİDA / TORX SCREW |
| 1415-M4X11 | M4X0.7 | 11 | 15 | 5.6 | 50 | S-SİSTEM için / For S-SYSTEM | TORK VİDA / TORX SCREW |
| 1515-M4X11 | M4X0.7 | 11.1 | 15 | 5.6 | 55 | S-SİSTEM için / For S-SYSTEM | TORK VİDA / TORX SCREW |
| 1515-M4X9 | M4X0.7 | 9 | 15 | 5.7 | 55 | S-SİSTEM için / For S-SYSTEM | TORK VİDA / TORX SCREW |
| 1615-M4X11 | M4X0.7 | 11.1 | 15 | 6 | 50 | S-SİSTEM için / For S-SYSTEM | TORK VİDA / TORX SCREW |
| 4015-M4X12 | M4X0.7 | 12 | 15 | 5.7 | 50 | S-SİSTEM için / For S-SYSTEM | TORK VİDA / TORX SCREW |
| 1015-M4.5X12 | M4.5X0.75 | 12 | 15 | 6.6 | 50 | S-SİSTEM için / For S-SYSTEM | TORK VİDA / TORX SCREW |
| 1020-M4.5X16 | M4.5X0.75 | 16 | 20 | 6.5 | 45 | S-SİSTEM için / For S-SYSTEM | TORK VİDA / TORX SCREW |
| 1120-M4.5X12 | M4.5X0.75 | 12.1 | 20 | 7.9 | R | S-SİSTEM için / For S-SYSTEM | TORK VİDA / TORX SCREW |
| 1515-M4.5X11 | M4.5X0.75 | 11 | 15 | 6.4 | 45 | S-SİSTEM için / For S-SYSTEM | TORK VİDA / TORX SCREW |
| 4020-M4.5X12 | M4.5X0.75 | 12 | 20 | 6.6 | 60 | S-SİSTEM için / For S-SYSTEM | TORK VİDA / TORX SCREW |
| 1020-M5X11 | M5X0.8 | 11 | 20 | 6.6 | 50 | S-SİSTEM için / For S-SYSTEM | TORK VİDA / TORX SCREW |
| 1020-M5X14 | M5X0.8 | 14.1 | 20 | 6.8 | 50 | S-SİSTEM için / For S-SYSTEM | TORK VİDA / TORX SCREW |
| 1615-M5X14 | M5X0.8 | 14 | 15 | 7.3 | 50 | S-SİSTEM için / For S-SYSTEM | TORK VİDA / TORX SCREW |
| 1020-M6X16 | M6X1.0 | 16 | 20 | 8.5 | 50 | S-SİSTEM için / For S-SYSTEM | TORK VİDA / TORX SCREW |
| 1420-M6X16 | M6X1.0 | 16 | 20 | 7.6 | 50 | S-SİSTEM için / For S-SYSTEM | TORK VİDA / TORX SCREW |
| 1520-M6X16 | M6X1.0 | 16 | 20 | 8.2 | 50 | S-SİSTEM için / For S-SYSTEM | TORK VİDA / TORX SCREW |
| 1710-U5-40X12.2 | UNC 5-40 | 12.2 | 10 | 5.6 | 60 | S-SİSTEM için / For S-SYSTEM | TORK VİDA / TORX SCREW |
| 1720-U8-32X15 | UNC 8-32 | 15 | 20 | 7.5 | 60 | S-SİSTEM için / For S-SYSTEM | TORK VİDA / TORX SCREW |

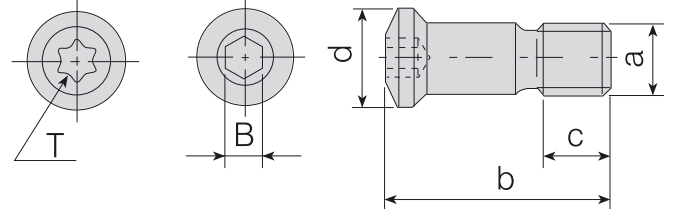

KÜRESEL FİNİŞ VİDALARI / BALL NOSE SCREWS

| Takım Kodu Ordering Code | a (M) | b | c | d | B(T) | Ürün Detayı Product Detail | |
|-----------------------------|---------|------|-----|------|------|--|---------------|
| 1208-M3x7 | M3x0.5 | 6.9 | 2.7 | 4.1 | 8 | KÜRESEL FREZE VİDASI / BALL NOSE SCREW | P3208 |
| 1215-M4X05X9 | M4X0.5 | 8.6 | 3.2 | 5.75 | 15 | KÜRESEL FREZE VİDASI / BALL NOSE SCREW | P3210-ROHX 12 |
| 1220-M5X05X9 | M5X0.5 | 9.6 | 3.4 | 6.8 | 20 | KÜRESEL FREZE VİDASI / BALL NOSE SCREW | P3212 |
| 1220-M5X05X12 | M5X0.5 | 12.9 | 4.4 | 7.4 | 20 | KÜRESEL FREZE VİDASI / BALL NOSE SCREW | P3216-ROHX 16 |
| 1220-M5X05X15 | M5X0.5 | 16.4 | 6 | 7.8 | 20 | KÜRESEL FREZE VİDASI / BALL NOSE SCREW | P3220-ROHX 20 |
| 1220-M6X0.75X20 | M6X0.75 | 20 | 6 | 9.4 | 20 | KÜRESEL FREZE VİDASI / BALL NOSE SCREW | P3225 |
| 1204-M8X0.75X26 | M8X0.75 | 26 | 7.5 | 12 | 4 | KÜRESEL FREZE VİDASI / BALL NOSE SCREW | P3232 |

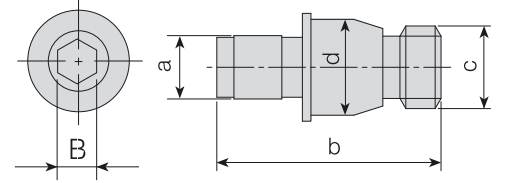

EKSANTRİK VİDA / ECCENTRIC SCREW

| Takım Kodu Ordering Code | a | b | c | d | B | Ürün Detayı Product Detail | |
|-----------------------------|------|----|--------|-----|-----|----------------------------------|---|
| AEV-01-M6x16 | 4.85 | 16 | M6x1.0 | 6.5 | 2.5 | EKSANTRİK VİDA / ECCENTRIC SCREW | PSDNN KARTUŞ için / for PSDNN CARTRIDGE |

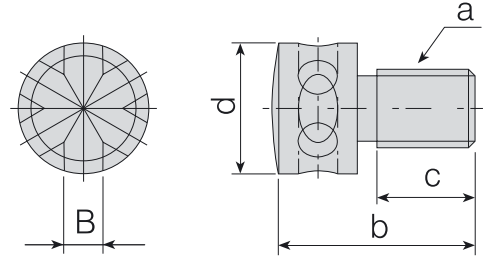

EKSENEL AYAR VİDALARI / AXIAL ADJUSTING SCREWS

| Takım Kodu Ordering Code | Eksenel Ayar Vidaları / Axial Adjusting Screws | | | | | Ürün Detayı Product Detail | Eksenel Ayar Vida / Axial Adjust Screw |
|-----------------------------|--|------|---|-----|-----|-------------------------------|--|
| | a (M) | b | c | d | B | | |
| 2600-M4x9.5 | M4x0.7 | 5.5 | 4 | 4 | 1.5 | KARTUŞ için / for CARTRIDGE | EKSENEL AYAR VİDA / AXIAL ADJUST SCREW |
| 2600-M5x13 | M5x0.5 | 12.8 | 7 | 8.7 | 2.5 | KARTUŞ için / for CARTRIDGE | EKSENEL AYAR VİDA / AXIAL ADJUST SCREW |
| 2600-M6x18 | M6x1.0 | 18.2 | 9 | 10 | 3.5 | KARTUŞ için / for CARTRIDGE | EKSENEL AYAR VİDA / AXIAL ADJUST SCREW |

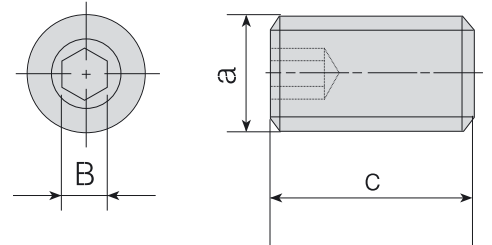

RADYAL AYAR VİDALARI / RADIAL ADJUSTING SCREWS

| Takım Kodu Ordering Code | Radial Ayar Vidaları / Radial Adjusting Screws | | | Ürün Detayı Product Detail | Kaba Bara Kartuşu için / for ROUGH BORING HEADS CARTRIDGE |
|-----------------------------|--|------|-----|---|---|
| | a (M) | c | B | | |
| 2715-M3x4 | M3x0.5 | 4 | 1.5 | KABA BARA için / for ROUGH BORING HEADS | KABA BARA KARTUŞU için / for ROUGH BORING HEADS CARTRIDGE |
| 2715-M3x5 | M3x0.5 | 5 | 1.5 | KABA BARA için / for ROUGH BORING HEADS | KABA BARA KARTUŞU için / for ROUGH BORING HEADS CARTRIDGE |
| 2715-M3X8 | M3x0.5 | 8 | 1.5 | KABA BARA için / for ROUGH BORING HEADS | KABA BARA KARTUŞU için / for ROUGH BORING HEADS CARTRIDGE |
| 2702-M4X10 | M4x0.7 | 10 | 2 | KARTUŞ için / for CARTRIDGE | KARTUŞ için / for CARTRIDGE |
| 2702-M4X12 | M4x0.7 | 12 | 2 | KABA BARA için / for ROUGH BORING HEADS | KABA BARA KARTUŞU için / for ROUGH BORING HEADS CARTRIDGE |
| 2725-M5X10 | M5x0.8 | 10 | 2.5 | KARTUŞ için / for CARTRIDGE | KARTUŞ için / for CARTRIDGE |
| 2725-M5X12 | M5x0.8 | 12 | 2.5 | KABA BARA için / for ROUGH BORING HEADS | KABA BARA KARTUŞU için / for ROUGH BORING HEADS CARTRIDGE |
| 2725-M5X14 | M5x0.8 | 14 | 2.5 | KABA BARA için / for ROUGH BORING HEADS | KABA BARA KARTUŞU için / for ROUGH BORING HEADS CARTRIDGE |
| 2703-M6X16 | M6x0.1 | 16 | 3 | KABA BARA için / for ROUGH BORING HEADS | KABA BARA KARTUŞU için / for ROUGH BORING HEADS CARTRIDGE |
| 2704-M8X25 | M8x1.25 | 25.9 | 4 | KABA BARA için / for ROUGH BORING HEADS | KABA BARA KARTUŞU için / for ROUGH BORING HEADS CARTRIDGE |

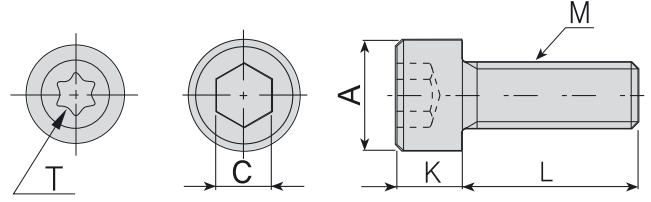

İNBUS CİVATALAR / INBUS SCREWS

| Takım Kodu Ordering Code | Ürün Detayı Product Detail | | | | | Ürün Detayı Product Detail | Ürün Detayı Product Detail |
|-----------------------------|-------------------------------|-------|-----|-----|-----|--|--|
| | M | A | C | K | L | | |
| 2503-M4x10 | M4x0.7 | 6.85 | 3 | 4 | 10 | KANAL KATERİ için / For GROOVING TOOLS | KANAL KATER VİDASI / SOME GROOVING TOOLS SCREW |
| 2525-M3X14 | M3X0.5 | 5.4 | 2.5 | 2.9 | 14 | BARA KARTUŞU için / for BORING HEADS CARTRIDGE | BARA KARTUŞU için SIKMA VİDASI / for BORING HEADS CARTRIDGE SCREW |
| 2503-M4X20 | M4x0.7 | 7 | 3 | 3.9 | 20 | BARA KARTUŞU için / for BORING HEADS CARTRIDGE | BARA KARTUŞU için SIKMA VİDASI / for BORING HEADS CARTRIDGE SCREW |
| 2503-M4X12 | M4x0.7 | 6.85 | 3 | 4 | 12 | KANAL KATERİ için / For GROOVING TOOLS | KANAL KATER VİDASI / SOME GROOVING TOOLS SCREW |
| 2503-M4X15 | M4x0.7 | 6.85 | 3 | 4 | 15 | BARA KARTUŞU için / for BORING HEADS CARTRIDGE | BARA KARTUŞU için SIKMA VİDASI / for BORING HEADS CARTRIDGE SCREW |
| 2504-M5X16 | M5X0.8 | 8.5 | 4 | 5 | 16 | KANAL KATERİ için / For GROOVING TOOLS | KANAL KATER VİDASI / SOME GROOVING TOOLS SCREW |
| 2504-M5X12 | M5X0.8 | 8.5 | 4 | 5 | 12 | KANAL KATERİ için / For GROOVING TOOLS | KANAL KATER VİDASI / SOME GROOVING TOOLS SCREW |
| 2504-M5X25 | M5X0.8 | 8.5 | 4 | 5 | 25 | BARA KARTUŞU için / for BORING HEADS CARTRIDGE | BARA KARTUŞU için SIKMA VİDASI / for BORING HEADS CARTRIDGE SCREW |
| 2505-M6X16 | M6X0.1 | 9.9 | 5 | 6 | 16 | KANAL KATERİ için / For GROOVING TOOLS | KANAL KATER VİDASI / SOME GROOVING TOOLS SCREW |
| 2505-M6X20 | M6X0.1 | 9.9 | 5 | 6 | 20 | KANAL KATERİ için / For GROOVING TOOLS | KANAL KATER VİDASI / SOME GROOVING TOOLS SCREW |
| 2505-M6X30 | M6X0.1 | 9.9 | 5 | 6 | 30 | BARA KARTUŞU için / for BORING HEADS CARTRIDGE | BARA KARTUŞU için SIKMA VİDASI / for BORING HEADS CARTRIDGE SCREW |
| 2406-M8X30 | M8X1.25 | 11.6 | 6 | 8.1 | 30 | FREZELEME TAKIMLARI için / for MILLING TOOLS | A16 MONTAJ VİDASI (KAFAS KÜÇÜK) / MOUNTING SCREW (SMALL HEAD) |
| 2506-M8X20 | M8X1.25 | 13 | 6 | 7.9 | 20 | KARTUŞ için / for CARTRIDGE | KARTUŞ MONTAJ VİDASI / CARTRIDGE MOUNTING SCREW |
| 2506-M8X30 | M8X1.25 | 13 | 6 | 8.1 | 30 | FREZELEME TAKIMLARI için / for MILLING TOOLS | A16 MONTAJ VİDASI / MOUNTING SCREW |
| 2506-M8X35 | M8X1.25 | 13 | 6 | 8.1 | 35 | BARA KARTUŞU için / for BORING HEADS CARTRIDGE | BARA KARTUŞU için SIKMA VİDASI / for BORING HEADS CARTRIDGE SCREW |
| 2406-M8X30 | M8X1.25 | 15.75 | 6 | 6 | 30 | FREZELEME TAKIMLARI için / for MILLING TOOLS | A16 MONTAJ VİDASI / MOUNTING SCREW |
| 2408-M8X30 | M8X1.25 | 13.9 | 8 | 10 | 30 | FREZELEME TAKIMLARI için / for MILLING TOOLS | A16 MONTAJ VİDASI / MOUNTING SCREW |
| 2407-M10X30 | M10X1.5 | 16 | 7 | 6 | 30 | FREZELEME TAKIMLARI için / for MILLING TOOLS | A22 MONTAJ VİDASI / MOUNTING SCREW |
| 2408-M10X30 | M10X1.5 | 13.90 | 8 | 10 | 30 | FREZELEME TAKIMLARI için / for MILLING TOOLS | A22 MONTAJ VİDASI / MOUNTING SCREW |
| 2508-M10X30 | M10X1.5 | 16 | 8 | 10 | 30 | FREZELEME TAKIMLARI için / for MILLING TOOLS | A22 MONTAJ VİDASI / MOUNTING SCREW |
| 2508-M10X40 | M10X1.5 | 16 | 8 | 10 | 40 | BARA KARTUŞU için / for BORING HEADS CARTRIDGE | BARA KARTUŞU için SIKMA VİDASI / for BORING HEADS CARTRIDGE SCREWS |
| 2408-M12X35 | M12X1.75 | 18 | 8 | 7 | 35 | FREZELEME TAKIMLARI için / for MILLING TOOLS | A27 MONTAJ VİDASI / MOUNTING SCREW |
| 2510-M12X35 | M12X1.75 | 18 | 10 | 12 | 35 | FREZELEME TAKIMLARI için / for MILLING TOOLS | A27 MONTAJ VİDASI / MOUNTING SCREW |
| 2514-M16X35 | M16X2.0 | 23.7 | 14 | 16 | 35 | FREZELEME TAKIMLARI için / for MILLING TOOLS | A32 MONTAJ VİDASI / MOUNTING SCREW |
| AAV-11-U5-40x4.5 | UNC 5-40 | 5.4 | T10 | 2.8 | 4.5 | DIŞ AÇMA TAKIMLARI için / for THREADING TOOLS | 16 ER/L, 16 IR/L ALTLIK VİDASI / SHIM SCREW |
| AAV-12-U8-32x5.5 | UNC 8-32 | 6.7 | T20 | 3.8 | 5.5 | DIŞ AÇMA TAKIMLARI için / for THREADING TOOLS | 16 ER/L, 16 IR/L ALTLIK VİDASI / SHIM SCREW |

SEKMAN / RING

| Ürün Resmi Product Picture | Ürün Kodu Product Code | Ürün Detayı Product Details | Ürün Detayı Product Details |
|-------------------------------|---------------------------|--------------------------------|--------------------------------|
| | | ACS-01 | C-SİSTEM için / For C-SYSTEM |

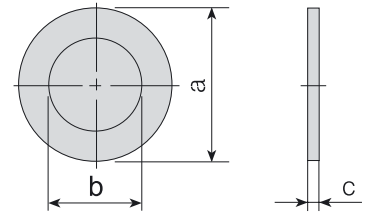

BASKI PULU / STAMP

| Takım Kodu Ordering Code | a | b | c | Ürün Detayı Product Detail | |
|-----------------------------|-------|-----|------|-------------------------------|------------|
| ABPL-01 | 11 | 6.5 | 0.5 | PUL / STAMP | BASKI PULU |
| ABPL-02 | 12.75 | 7.1 | 0.45 | PUL / STAMP | BASKI PULU |

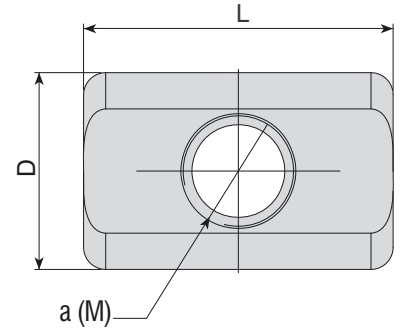

BARA PABUÇLARI / BORING HEADS CARTRIDGE

| Takım Kodu Ordering Code | a (M) | D | L | Ürün Detayı Product Detail | |
|-----------------------------|----------|------|----|---|---|
| ABKS-D16 | M3x0.5 | 4.9 | 6 | KABA BARA için / for ROUGH BORING HEADS | ABHR-D16x42-W16-L90 |
| ABKS-D20 | M4x0.7 | 5.9 | 9 | KABA BARA için / for ROUGH BORING HEADS | ABHR-D20x50-W20-L100 |
| ABKS-D25 | M4x0.7 | 5.9 | 12 | KABA BARA için / for ROUGH BORING HEADS | ABHR-D25x60-W20-L110 |
| ABKS-D32 | M5x0.8 | 8.9 | 14 | KABA BARA için / for ROUGH BORING HEADS | ABHR-D32x64-W25-L120 |
| ABKS-D40 | M6x1 | 10.9 | 18 | KABA BARA için / for ROUGH BORING HEADS | ABHR-D40x80-W32-L140 |
| ABKS-D50 | M8x1.25 | 13.9 | 28 | KABA BARA için / for ROUGH BORING HEADS | ABHR-D50x100-W32-L160 |
| ABKS-D63 | M10x1.5 | 15.9 | 35 | KABA BARA için / for ROUGH BORING HEADS | ABHR-D63x80-W32-L140, ABHR-D63x130-W40-L200 |
| ABKS-D80 | M12x1.75 | 17.9 | 45 | KABA BARA için / for ROUGH BORING HEADS | ABHR-D80x140-W40-L210, ABHR-D80x140-W40-L210 -B |

ALYAN ANAHTARLARI / ALLEN KEYS

| Ürün Resmi Product Picture | Ürün Kodu Product Code | Ürün Detayı Product Details |
|--|---------------------------|------------------------------------|
|  | AAL-01-2 | 2 mm ALYAN ANAHTARI / ALLEN KEYS |
| | AAL-02-2.5 | 2.5 mm ALYAN ANAHTARI / ALLEN KEYS |
| | AAL-03-3 | 3 mm ALYAN ANAHTARI / ALLEN KEYS |
| | AAL-05-4 | 4 mm ALYAN ANAHTARI / ALLEN KEYS |
| | AAL-07-5 | 5 mm ALYAN ANAHTARI / ALLEN KEYS |
| | AAL-08-6 | 6 mm ALYAN ANAHTARI / ALLEN KEYS |
| | AAL-09-1.5 | 1.5 mm ALYAN ANAHTARI / ALLEN KEYS |

TORK ANAHTARLARI / TORX KEYS

| Ürün Resmi Product Picture | Ürün Kodu Product Code | Ürün Detayı Product Details |
|--|---------------------------|---|
|  | 80-T06 | T06 TORK ANAHTARI / TORX KEY |
| | 80-T07 | T07 TORK ANAHTARI / TORX KEY |
| | 80-T08 | T08 TORK ANAHTARI / TORX KEY |
| | 80-T10 | T10 TORK ANAHTARI / TORX KEY |
| | 80-T15 | T15 TORK ANAHTARI / TORX KEY |
| | 80-T20 | T20 TORK ANAHTARI / TORX KEY |
| | 81-T15 | T15 T-TİP TORK ANAHTARI / T-TYPE TORX KEY |
| | 81-T20 | T20 T-TİP TORK ANAHTARI / T-TYPE TORX KEY |



konusulan
the spoken kalite...
quality...







